

Teilekatalog  
Parts catalogue  
Catalogue de pièces  
Reservdelskatalog  
Catalogo dei pezzi di ricambio

**D 150**

**D 190**

**D 530**

**D 636**



# BMW Marine Motor

V12 Engineering

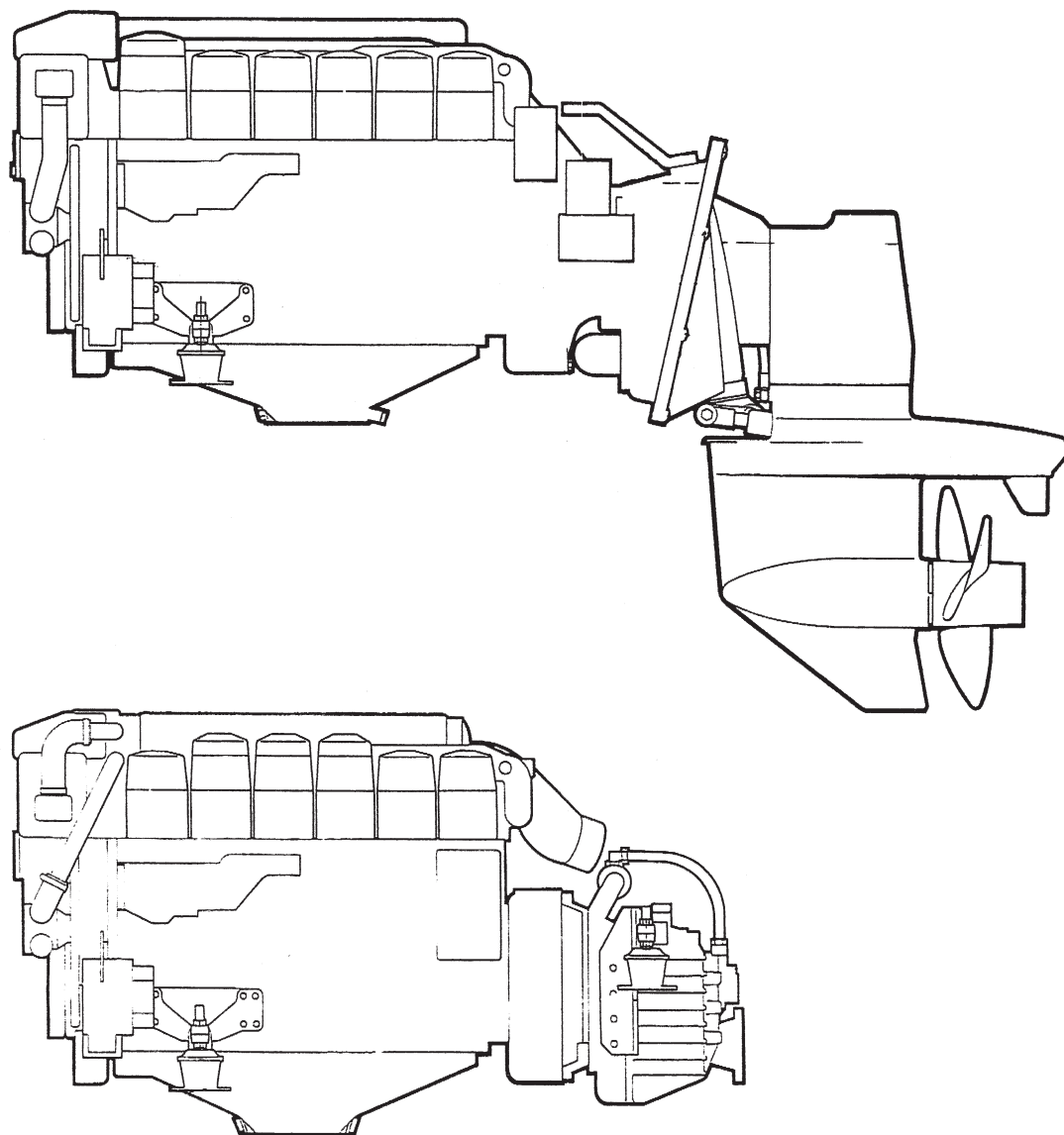

BMW Marine GmbH  
München

Der vorliegende Teilekatalog gilt für den Bootsmotor D 150 / D 190 / D 530 / D 636.  
Die bis April 1986 erfolgten Änderungen sind berücksichtigt. Nach diesem Zeitpunkt  
anfallende Änderungen werden Ihnen mit Nachträgen bekanntgegeben.

The present spare parts catalogue applies to the BMW D 150 / D 190 / D 530 / D 636 marine  
engine. All amendments are included up to April 1986. Later amendments will be  
communicated with the aid of modification lists.

Le présent catalogue des pièces de rechange est valable pour le moteur de canot  
BMW D 150 / D 190 / D 530 / D 636.  
Les modifications jusqu'au mois de avril 1986 sont prise en considération. Après ce temps  
les modifications ayant lieu vous seront communiquées à l'aide des suppléments.

Den befintliga katalogen gå för båtmotoren BMW D 150 / D 190 / D 530 / D 636.  
Ändringar till april 1986 är inbegripad. Alla ändringar efter denna tidpunkten skal  
tillkännagivas med supplementer.

Il presente catalogo dei pezzi di ricambio vale per il motore marino  
D 150 / D 190 / D 530 / D 636.  
Sono state tenute in considerazione le modifiche effettuate fino a aprile 1986.

Der Teilekatalog umfaßt alle Teile der genannten Baumuster. Sein Aufbau und sein System ermöglichen es, durch einfaches Auswechseln der Blätter Änderungen und Ergänzungen schnell und sauber zu übernehmen.

Beim Austausch der Blätter ist auf die Seite und das Ausgabedatum zu achten. Die alten Blätter, die durch neue ersetzt werden, sind aus dem Katalog zu entfernen.

Abbildungen und Texte unterliegen einem ständigen Änderungsdienst.

This catalogue lists all spare parts for the type mentioned. The loose-leaf system enables the user to carry out modifications and additions quickly and accurately by simply replacing the sheets concerned.

To file new pages correctly check the page number and date of issue. Remove the superseded pages from the catalogue.

Illustrations and text are subject to continuous modifications.

Le catalogue des pièces de rechange comprend toutes les pièces des modèles type mentionnés. Sa structure et son système rendent possible de faire des modifications et suppléments simplement par remplacement des feuilles.

En remplaçant les feuilles il faut faire attention à la page et la date d'édition.

Ecartez les vieilles feuilles, remplacées par des nouvelles, du catalogue.

Les figures et textes sont soumises d'un service de modification continu.

Denna katalog innesluta alla fordöndelar för uppförande modellen. Struktur och system möjliggöra överta ändringar och supplementer snabbt och ackurat genom utväxling av blad.

Om bladen är utväxlat gi akt på sidan och utmatade data. Gammla blad som ersättas med nya skal tas fram katalogen.

Avbildningar och texter skal modifieras kontinuerligt.

Il catalogo dei pezzi di ricambio comprende tutti i pezzi dei modelli di costruzione indicati. La sua disposizione ed il suo sistema consente, mediante semplice scambio dei fogli, di effettuare modifiche ed integrazioni in modo rapido e pulito.

Nel sostituire i fogli si dovrà tenere in considerazione la pagina e la data di emissione. I fogli vecchi che verranno sostituiti con nuovi, sono da eliminare dal catalogo.

Le illustrazioni ed i testi sono soggetti ad un costante servizio modifiche.

KOPFLEISTEN SYMBOLE / TOP LINE SYMBOLS / SYMBOLES DES TITRES /  
 ÖVERSKRIFT SYMBOLER / SOMBOLI DI CORNICE

Nr.	Bildnummer / Figure number / Numéro de figure / Bildnummer / Numero della figura
Teile-Nummer	Teilenummer / Parts number / Numéro des pièces / Delnummer / Numero del pezzo
Symbol	Symbol / Symbol / Symbole / Symbol / Simbolo
Benennung	Benennung / Designation / Nomenclature / Benämning / Denominazione
Bemerkung	Bemerkung / Note / Note / Anmärkning / Osservazione
HG	Hauptgruppe / Main group / Groupe principale / Huvudgrupp / Gruppo principale
S	Seite / Page / Page / Sida / Pagina

TEXTSEITEN SYMBOLE / TEST PAGE SYMBOLS / SYMBOLES DES PAGES  
 DE TEXTE / SYMBOLER AV TEXTSIDORNA / SIMBOLI DELLE PAGINE DI TESTO

	In der Teilenummern-Spalte / In the parts number column / Dans la colonne des numéros des pièces / I delnummerkolumnen / Nella colonna dei numeri dei pezzi di ricambio
a...z	Hinweis auf Bemerkungsfeld / Reference to the remarks field / Renvoi à case de notes / Hänvisning till anmärkningsfältet / Avvertenze nella casella delle osservazioni
E	Entfallen (Teil nicht mehr lieferbar) Deleted (parts no longer available) Supprimé (les pièces ne sont plus livrables) Utfalla (delar kan inte mera leveras) Non interessa (pezzi non sono più fornibili)

In der Symbol-Spalte / In the symbol column / Dans la colonne des symboles /  
 I symbolkolumnen / Nella colonna dei simboli

A	Austauschbar durch die Teilenummer der nächsten Zeile Replaceable by the parts number of the next line Interchangeable avec les numéros des pièces de la ligne suivant Kan utbytes med delnumret av nästa raden Intercambiabile col numero dei pezzi di ricambio della prossima riga
L	Links / left / gauche / vänster / a sinistra
R	Rechts / right / droite / höger / a destra
V	Vorn / front / avant / framför / anteriore, avanti
H	Hinten / rear / arrière / baktill / posteriore, dietro
O	Linkslenkung / Left-hand drive / Direction à gauche / Vänsterstyrning / Sterzo a sinistra
OO	Rechtlenkung / Right-hand drive / Direction à droite / Högerstyrning / Sterzo a destra
WW	Wahlweise / Optional / Facultatif / Till urval / A scelta
RS	Reparatursatz / Repair kit / Jeu de réparation / Reparationssats / Corredo di riparazione
DS	Dichtungssatz / Gasket set / Jeu de joints / Tätningssats / Corredo di guarnizioni

In der Benennungs-Spalte / In the designation column / Dans la colonne de nomenclature / I benämningsskolumnen / Nella colonna di denominazione

DIN-Abkürzungen / DIN abbreviations / Abréviations DIN /  
DIN-avkortningar / Abbreviazioni DIN (norma industr. tedesca)

BL MU	Blechmutter / Sheet metal nut / Erou Parker / Plåtmutter / Dado per lamiera
BL SHR	Blechschaube / Parker screw / Vis Parker / Plåtskruv / Vite di lamiera
DT RG	Dichtring / Sealing ring / Bague d'étanchéité / Packningsring / Anello di guarn. de tenuta
LIN BL SHR	Linsenblechschaube / Fillister head self-tapping screw / Vis parker à tête bombée / Plåtskruv med kullrigt huvud / Vite lentic di lamiera
LIN SHR	Linsenschraube / Fillister head screw / Vis à tête bombée / Skruv med kullrigt huvud / Vite testa cil.
LINSK BL SHR	Linsensenkschraube / Countersunk parker screw / Vis conique bombée pour tôle / Plåtskruv med försänkt huvud / Vite testa scasata calotta per lamiera
LIN SK SHR	Linsensenkschraube / Raised countersunk head screw / Vis à tête fraisée bombée / Skruv med försänkt kullrigt huvud / Vite testa scasata con cal.
MU	Mutter / Nut / Moer / Mutter / Dado
PA SHB	Passscheibe / Disc ring / Pasring / Passbricka / Anello piatto
SHR	Schraube / Screw / Vis / Bult / Vite
SK BL SHR	Senkschraube / Countersunk self-tapping screw / Vis parker à tête fraisée / Plåtskruv med försänkt huvud / Vite a testa scasata p. lamiera
SK SHR	Senkschraube / Countersunk head screw / Vis à tête fraisée / Skruv med försänkt huvud / Vite a testa scasata
STI SHR	Stiftschraube / Stud / Goujon fileté / Pinnbult / Vite a perno
VSL SHR	Verschlussschraube / Plug screw / Boucon fileté / Skruvpropp / Tappo
ZYL SHR	Zylinderschraube / Fillister head screw / Erou cylindrique / Zylinderskruv / Dado cilindro
ZYL STI	Zylinderstift / Dowel pin / Goupille cylindrique / Zylinderstift / Perno di centraggio
4 KT MU	Vierkantmutter / Square nut / Erou carré / Fyrkantmutter / Dado a testa cuadra
6 KT MU	Sechskantmutter / Hexagon nut / Erou à six pans / Sekskantmutter / Dado esagonale
6 KT SHR	Sechskantschraube / Hexagon head nut / Vis hexagonale / Sekskantbult / Vite esagonale

Sonstige Abkürzungen / Other abbreviations / Autres abréviations /  
Övriga avkortningar / Altre abbreviazioni

kpl. dito	komplett / complete / complet / komplett / completo Benennung identisch mit vorhergehendem Textteil / Designation identical with preceding text part / Dénomination identique avec le texte précédent / Benämning identisk med föregående text / Denominazione identica con la parte del testo precedente
∅	Durchmesser / Diameter / Diamètre / Diameter / Diametro

In der Baumusterspalte / In the type column / Dans la colonne du modèle type /  
I typskolumnen / Nella colonna dei modelli di costruzione

X	laufende Meter oder Stück nach Bedarf / per running metre or unit, as required / par mètre courant ou pièce suivant les besoin / per löpande meter eller stycke efter behov / metri lunghi o pezzi a secondo del fabbisogno
---	---

Hinweis und Bemerkungsfeld / Remarks and comments box / Indication  
concernant la colone d'observations / Hänvisnings- och anteckningsfält /  
Casella di indicazioni e di osservazioni

- a...z      Bemerkung für alle mit diesem Kleinbuchstaben gekennzeichneten Teilenummern /  
Note for all part numbers identified by these small letters / Note pour tous les  
numéros des pièces détachées repérés par ces minuscules / Anmärkning för alla  
delnummer kännetecknad med denna små bokstäver / Osservazione per tutti  
i numeri di pezzi di ricambio contrassegnati con questa lettera minuscola
- i.V.m.      nur in Verbindung mit / only in connection with / seulement en connexion avec /  
endast in samband med / solo un collegamento con
- n.p.z.      nur passend zu / only suitable for / seulement assorti à /  
endast in samband med / adatto solo per
- Mot      bis Motor-Nummer / up to engine no / Jusqu'au moteur no / till motor nr /  
fino a motore-numero
- Mot →      ab Motor-Nummer / as from engine no / à partir du moteur / från motor nr /  
a partire dal motore-numero
- dito      Motor-Nummer identisch mit vorhergehender Bemerkung / Engine no.  
identical with preceding note / Numéro moteur identique avec la note  
précédente / Motor nr identisk med föregående anmärkning /  
Motore-numero identico con la precedente osservazione

Um Ihre Kunden jederzeit zufriedenstellen zu können, benötigen Sie stets einen ausreichenden Vorrat an Teilen und Zubehör.

Eine exakte Disposition und eindeutige rechtzeitige Bestellungen sind hierfür die wichtigsten Voraussetzungen.

Was ist bei den Teile-Bestellungen zu beachten?

1. Denken Sie immer an die 3 Grundangaben: Teilenummer, Bezeichnung, Stückzahl.
2. Führen Sie Ihre Bestellungen stets in numerischer Reihenfolge auf.
3. Vergessen Sie bei Ihrer Bestellung nicht die Unterschrift, den Firmenstempel, das Bestelldatum sowie Versandvorschriften.
4. Nur bei schriftlich aufgegebenen Bestellungen kann der ausliefernde Partner die Gewähr für die Richtigkeit der Lieferung übernehmen; bemühen Sie sich daher bitte, Ihre Bestellungen weitgehend schriftlich (möglichst per Schreibmaschine) zu erteilen.
5. Teile-Bestellungen und Teiledienst betreffende Korrespondenz sind zu richten an:  

BMW Marine GmbH.	Fernschreiber:
Ingolstädter Strasse 65c	52 15580 bmwm d
8000 München 45	
Abt. Teiledienst	
6. Telefonische Bestellungen können unter der Nummer (089) 3 18 16-212/279 aufgegeben werden.
7. Alle Teile-Sendungen erfolgen unter Zugrundelegung der jeweils gültigen Verkaufs- und Lieferbedingungen der BMW Marine GmbH.

To be able to meet your customers' requirements at any time you always should have sufficient stock of parts and accessories.

Exact arrangements and clear orders placed in good time are the most important prerequisites to solve this problem in an adequate way.

What should be observed in ordering spare parts?

1. Always remember the three basic data: parts number, designation, quantity.
2. Always give our order in numerical sequence.
3. Prior to dispatching your order make sure that you have not forgotten your signature, your firm's seal, date of order and shipping instructions.
4. Only an order in writing ensures correct delivery by the supplier. Therefore, try by all means to give your order in writing (if possible typed on a typewriter).
5. As for spare parts orders and parts service address your correspondence to:

BMW Marine GmbH.  
Ingolstädter Strasse 65c  
D-8000 München 45  
Federal Republic of Germany  
Abt. Teiledienst

Telex:  
52 15580 bmwm d

6. Orders by telephone can be placed dialling (089) 3 18 16-212/279
7. All spare parts deliveries are subject to the Conditions of Sale and Delivery of the BMW Marine GmbH being in force at that time.



Pour être à même de satisfaire votre clientèle en tout temps vous avez besoin toujours d'un stock de pièces de rechange et d'accessoires suffisant.

Une disposition exacte et des commandes claires données à temps sont les conditions les plus importantes à cela.

Qu'est-ce qu'il faut prendre en considération en commandant des pièces de rechange?

1. Rappelez toujours les 3 données de base: Numéro de la pièce de rechange, nomenclature, nombre des pièces.
2. Donnez votre commande toujours en ordre numérique.
3. N'oubliez pas la signature, le cachet de votre maison, la date de commande et les instructions d'expédition.
4. Le fournisseur ne peut garantir l'exactitude de la livraison que si la commande est donnée en forme écrite. Pour cette raison essayez en tout cas de donner votre commande par écrit (dans la mesure possible tapée à la machine).
5. Adressez votre correspondance concernant des commandes des pièces de rechange et le service de rechange à:

BMW Marine GmbH.  
Ingolstädter Strasse 65c  
D-8000 München 45  
Abt. Teiledienst

Telex:  
52 15580 bmwm d

6. Les commandes peuvent être données par téléphone sous le numéro (089) 3 18 16-212/279
7. Toutes les fournitures des pièces de rechange sont effectuées à la base des Conditions de Vente et de Livraison des la BMW Marine GmbH.

Teilenummern-Index  
 Part Number index  
 Index des numéros de pièces  
 Reservdelnummer-Index  
 Indice dei numeri dei pezzi di ricambio

**00**  
**11**  
 4/86

D 150 / D 190 / D 530 / D 636

Teile-Nummer	HG	S	Nr.	Teile-Nummer	HG	S	Nr.	Teile-Nummer	HG	S	Nr.
07 11 1763 263	17	2	41	07 11 9912 506	11	14	6	07 11 9913 477	11	7	22
07 11 9900 816	11	15	12	07 11 9912 506	12	1	17	07 11 9913 483	11	7	5
07 11 9900 816	17	2	44	07 11 9912 516	11	17	5	07 11 9913 483	17	5	13
07 11 9902 520	62	1	23	07 11 9912 516	11	18	12	07 11 9913 616	17	4	26
07 11 9902 520	62	2	2	07 11 9912 516	11	22	11	07 11 9913 624	11	21	6
07 11 9902 520	62	3	2	07 11 9912 524	27	14	7	07 11 9913 624	17	4	17
07 11 9905 420	74	5	40	07 11 9912 524	27	15	18	07 11 9913 624	17	5	14
07 11 9905 422	13	3	25	07 11 9912 529	11	5	14	07 11 9913 624	17	6	8
07 11 9906 020	74	1	14	07 11 9912 529	74	3	14	07 11 9913 624	21	1	15
07 11 9906 025	74	1	4	07 11 9912 535	11	20	7	07 11 9913 624	27	13	6
07 11 9907 583	12	6	5	07 11 9912 553	27	15	9	07 11 9913 644	11	20	19
07 11 9907 583	12	7	5	07 11 9912 562	12	1	20	07 11 9913 644	11	8	20
07 11 9907 633	12	4	5	07 11 9912 567	12	1	20	07 11 9913 644	27	17	19
07 11 9907 633	12	5	5	07 11 9912 578	27	15	8	07 11 9913 657	11	14	7
07 11 9907 666	27	4	6	07 11 9912 672	11	19	13	07 11 9913 657	11	17	8
07 11 9907 666	62	2	22	07 11 9912 729	74	5	6	07 11 9913 657	17	2	35
07 11 9907 666	62	3	22	07 11 9913 218	11	12	17	07 11 9913 657	27	10	3
07 11 9907 688	12	5	16	07 11 9913 218	13	3	11	07 11 9913 657	74	3	10
07 11 9907 688	12	6	15	07 11 9913 218	13	3	39	07 11 9913 662	11	18	9
07 11 9907 688	12	7	15	07 11 9913 241	13	4	7	07 11 9913 662	74	5	28
07 11 9908 310	11	15	16	07 11 9913 251	27	16	13	07 11 9913 676	27	17	12
07 11 9908 310	11	16	7	07 11 9913 410	11	14	16	07 11 9913 689	11	8	6
07 11 9908 355	27	3	4	07 11 9913 410	11	7	5	07 11 9913 807	13	3	29
07 11 9908 400	27	5	7	07 11 9913 426	11	14	13	07 11 9913 807	27	15	2
07 11 9908 402	11	10	2	07 11 9913 442	11	7	10	07 11 9913 807	27	16	9
07 11 9909 054	11	15	6	07 11 9913 442	12	4	7	07 11 9913 815	12	4	14
07 11 9909 054	27	3	5	07 11 9913 442	13	2	21	07 11 9913 815	12	5	13
07 11 9909 054	27	5	9	07 11 9913 442	13	3	30	07 11 9913 815	12	5	17
07 11 9909 067	11	15	28	07 11 9913 442	27	13	8	07 11 9913 815	12	6	13
07 11 9909 067	17	2	30	07 11 9913 446	74	4	6	07 11 9913 815	12	7	13
07 11 9909 079	27	16	5	07 11 9913 450	11	7	10	07 11 9913 815	13	8	2
07 11 9909 106	11	17	18	07 11 9913 466	11	7	5	07 11 9913 815	17	4	19
07 11 9909 355	27	5	8	07 11 9913 466	13	3	17	07 11 9913 815	17	5	15
07 11 9909 808	74	4	15	07 11 9913 466	13	4	21	07 11 9913 834	12	1	9

Teilenummern-Index  
 Part Number index  
 Index des numéros de pièces  
 Reservdelsnummer-Index  
 Indice dei numeri dei pezzi di ricambio

**00**  
**12**

4/86

D 150 / D 190 / D 530 / D 636

Teile-Nummer	HG	S	Nr.	Teile-Nummer	HG	S	Nr.	Teile-Nummer	HG	S	Nr.
07 11 9913834	12	2	11	07 11 9919632	27	9	15	07 11 9920066	74	3	16
07 11 9913834	13	2	16	07 11 9919643	27	17	6	07 11 9921014	74	2	9
07 11 9913837	11	10	9	07 11 9919644	11	19	11	07 11 9921014	74	5	8
07 11 9913837	27	14	4	07 11 9919669	11	20	10	07 11 9921038	12	1	4
07 11 9913837	27	15	15	07 11 9919669	74	3	4	07 11 9921053	27	7	9
07 11 9913837	27	16	2	07 11 9919682	11	8	26	07 11 9921059	74	5	36
07 11 9913843	11	7	27	07 11 9919689	21	1	10	07 11 9921077	11	15	8
07 11 9913843	13	1	4	07 11 9919697	27	9	13	07 11 9921077	11	16	15
07 11 9913843	13	2	16	07 11 9919746	27	6	43	07 11 9921077	11	17	19
07 11 9913843	21	1	12	07 11 9919747	27	5	15	07 11 9921100	74	2	19
07 11 9913859	11	22	7	07 11 9919747	27	7	4	07 11 9921100	74	5	7
07 11 9913889	27	14	12	07 11 9919775	27	3	38	07 11 9921102	27	15	12
07 11 9913898	74	2	13	07 11 9919775	27	7	19	07 11 9921607	11	12	9
07 11 9913898	74	5	3	07 11 9919775	27	8	43	07 11 9921631	12	2	9
07 11 9913908	27	18	51	07 11 9919775	27	9	28	07 11 9922028	12	6	6
07 11 9913917	27	14	12	07 11 9919781	11	15	5	07 11 9922028	12	7	6
07 11 9913943	27	8	16	07 11 9919785	27	6	45	07 11 9922038	12	4	19
07 11 9915039	17	5	7	07 11 9919926	11	16	21	07 11 9922038	12	5	6
07 11 9917409	13	2	11	07 11 9919926	11	8	7	07 11 9922038	13	3	12
07 11 9917409	17	1	12	07 11 9919933	11	2	8	07 11 9922058	11	7	23
07 11 9917409	27	12	6	07 11 9919940	11	13	15	07 11 9922058	11	8	12
07 11 9919016	27	17	23	07 11 9919940	11	13	6	07 11 9922058	13	2	23
07 11 9919018	27	7	37	07 11 9919961	11	16	22	07 11 9922058	13	7	4
07 11 9919112	11	17	11	07 11 9919962	74	3	3	07 11 9922058	17	1	4
07 11 9919114	17	2	28	07 11 9919965	11	8	28	07 11 9922058	17	2	27
07 11 9919115	27	8	32	07 11 9919965	17	2	5	07 11 9922058	17	7	12
07 11 9919119	27	9	34	07 11 9919967	11	17	15	07 11 9922058	17	8	12
07 11 9919131	17	1	14	07 11 9919967	11	18	2	07 11 9922058	27	13	9
07 11 9919217	11	18	3	07 11 9919967	17	1	9	07 11 9922073	27	3	10
07 11 9919246	11	14	2	07 11 9919969	11	15	25	07 11 9922073	27	5	3
07 11 9919593	27	5	5	07 11 9919978	11	21	10	07 11 9922087	11	10	5
07 11 9919632	27	6	3	07 11 9919978	17	3	4	07 11 9922087	11	20	13
07 11 9919632	27	7	2	07 11 9919978	74	3	18	07 11 9922087	11	21	7
07 11 9919632	27	8	8	07 11 9920066	17	3	3	07 11 9922087	13	2	6

Teilenummern-Index  
 Part Number index  
 Index des numéros de pièces  
 Reservdelsnummer-Index  
 Indice dei numeri dei pezzi di ricambio

**00**  
**13**

4/86

D 150 / D 190 / D 530 / D 636

Teile-Nummer	HG	S	Nr.	Teile-Nummer	HG	S	Nr.	Teile-Nummer	HG	S	Nr.
07 11 9922 087	13	5	12	07 11 9928 796	27	8	29	07 11 9931 088	12	1	6
07 11 9922 087	17	2	12	07 11 9930 840	11	15	19	07 11 9931 094	27	15	11
07 11 9922 087	17	4	11	07 11 9930 840	13	3	7	07 11 9931 332	27	14	11
07 11 9922 087	17	5	11	07 11 9931 036	11	12	16	07 11 9931 633	27	4	7
07 11 9922 087	17	6	9	07 11 9931 036	11	7	37	07 11 9931 647	27	7	34
07 11 9922 087	27	10	5	07 11 9931 036	13	4	9	07 11 9931 647	27	8	40
07 11 9922 087	27	13	7	07 11 9931 044	11	7	4	07 11 9931 647	27	9	35
07 11 9922 087	27	17	21	07 11 9931 044	12	4	9	07 11 9931 652	13	3	38
07 11 9922 113	11	7	29	07 11 9931 044	12	5	10	07 11 9931 652	13	4	22
07 11 9922 113	12	1	11	07 11 9931 044	12	6	10	07 11 9931 655	27	7	15
07 11 9922 113	12	2	13	07 11 9931 044	12	7	10	07 11 9931 660	11	13	11
07 11 9922 113	13	1	6	07 11 9931 044	13	3	27	07 11 9931 660	74	2	2
07 11 9922 133	12	3	3	07 11 9931 067	11	10	3	07 11 9931 660	74	5	31
07 11 9922 133	13	3	40	07 11 9931 067	11	15	24	07 11 9931 661	21	1	11
07 11 9922 133	27	3	40	07 11 9931 067	11	21	5	07 11 9931 664	74	2	25
07 11 9922 176	11	22	6	07 11 9931 067	11	5	13	07 11 9931 664	74	5	46
07 11 9922 176	27	14	10	07 11 9931 067	11	8	5	07 11 9931 674	74	2	14
07 11 9922 417	13	7	6	07 11 9931 067	12	1	15	07 11 9931 674	74	5	4
07 11 9922 420	27	5	14	07 11 9931 067	12	2	15	07 11 9931 675	27	9	12
07 11 9922 420	27	6	46	07 11 9931 067	17	4	10	07 11 9931 682	17	3	2
07 11 9922 420	27	7	21	07 11 9931 067	17	6	12	07 11 9931 682	74	3	17
07 11 9922 420	27	8	39	07 11 9931 067	27	15	5	07 11 9932 047	12	1	3
07 11 9922 426	12	1	19	07 11 9931 067	27	16	6	07 11 9932 047	13	3	13
07 11 9922 426	27	15	16	07 11 9931 067	74	4	4	07 11 9932 070	11	14	14
07 11 9922 449	27	9	26	07 11 9931 067	74	5	38	07 11 9932 071	11	7	13
07 11 9922 493	27	9	18	07 11 9931 076	11	19	12	07 11 9932 072	11	14	15
07 11 9922 714	12	2	16	07 11 9931 076	11	2	7	07 11 9932 072	11	15	26
07 11 9922 714	74	2	3	07 11 9931 076	11	22	2	07 11 9932 072	11	16	20
07 11 9922 714	74	3	5	07 11 9931 076	12	1	10	07 11 9932 072	11	18	4
07 11 9922 729	74	2	15	07 11 9931 076	12	2	12	07 11 9932 072	11	7	26
07 11 9922 808	27	15	6	07 11 9931 076	13	1	5	07 11 9932 072	11	8	11
07 11 9923 100	74	2	10	07 11 9931 076	21	1	19	07 11 9932 072	13	2	22
07 11 9923 100	74	5	12	07 11 9931 084	27	14	11	07 11 9932 072	17	1	3
07 11 9926 243	21	1	3	07 11 9931 084	74	5	34	07 11 9932 072	17	2	26

Teilenummern-Index  
 Part Number index  
 Index des numéros de pièces  
 Reservdelsnummer-Index  
 Indice dei numeri dei pezzi di ricambio

**00**  
**14**

4/86

D 150 / D 190 / D 530 / D 636

Teile-Nummer	HG	S	Nr.	Teile-Nummer	HG	S	Nr.	Teile-Nummer	HG	S	Nr.
07 11 9932 081	13	3	21	07 11 9933 096	11	13	5	07 11 9963 072	11	18	17
07 11 9932 081	13	4	17	07 11 9933 096	13	5	11	07 11 9963 072	11	2	16
07 11 9932 084	27	3	28	07 11 9933 110	11	22	3	07 11 9963 072	11	20	27
07 11 9932 084	27	5	6	07 11 9933 127	13	3	41	07 11 9963 072	13	3	35
07 11 9932 084	27	6	4	07 11 9933 149	12	2	1	07 11 9963 129	13	1	11
07 11 9932 084	27	7	3	07 11 9933 251	11	8	25	07 11 9963 129	13	2	12
07 11 9932 084	27	8	9	07 11 9934 132	74	2	18	07 11 9963 129	13	5	15
07 11 9932 084	27	9	14	07 11 9934 132	74	5	23	07 11 9963 130	11	20	26
07 11 9932 093	11	16	9	07 11 9934 175	27	15	17	07 11 9963 130	17	1	11
07 11 9932 095	11	10	4	07 11 9934 959	74	5	17	07 11 9963 150	27	12	5
07 11 9932 095	11	13	14	07 11 9935 942	21	1	13	07 11 9963 200	11	21	3
07 11 9932 095	11	14	5	07 11 9936 425	13	7	7	07 11 9963 200	13	2	24
07 11 9932 095	11	15	4	07 11 9936 425	13	8	11	07 11 9963 200	17	2	29
07 11 9932 095	11	16	14	07 11 9936 433	27	3	37	07 11 9963 201	11	2	12
07 11 9932 095	11	17	4	07 11 9936 436	27	15	3	07 11 9963 201	11	7	24
07 11 9932 095	11	18	16	07 11 9936 442	27	3	11	07 11 9963 201	12	4	20
07 11 9932 095	11	19	10	07 11 9937 241	11	2	3	07 11 9963 201	13	1	9
07 11 9932 095	11	20	8	07 11 9937 332	17	2	38	07 11 9963 201	13	2	10
07 11 9932 095	11	8	19	07 11 9940 976	27	5	10	07 11 9963 201	13	5	17
07 11 9932 095	13	2	5	07 11 9941 385	27	17	16	07 11 9963 201	17	2	11
07 11 9932 095	17	2	34	07 11 9941 389	27	7	23	07 11 9963 252	27	17	11
07 11 9932 095	27	17	5	07 11 9941 485	11	9	17	07 11 9963 290	17	2	4
07 11 9932 104	11	20	11	07 11 9945 098	27	7	16	07 11 9963 308	11	14	11
07 11 9932 110	11	9	9	07 11 9945 113	13	3	26	07 11 9963 308	11	18	14
07 11 9932 112	11	10	8	07 11 9945 225	74	2	5	07 11 9963 308	11	6	11
07 11 9932 112	13	2	15	07 11 9945 225	74	5	45	07 11 9963 342	11	19	20
07 11 9932 117	27	8	17	07 11 9945 255	27	9	20	07 11 9963 342	11	4	19
07 11 9932 132	12	3	2	07 11 9948 511	74	1	13	07 11 9963 342	17	4	5
07 11 9932 646	13	3	23	07 11 9951 453	12	1	18	07 11 9963 354	11	19	18
07 11 9932 646	13	4	18	07 11 9962 507	27	3	27	07 11 9963 354	11	20	21
07 11 9932 710	74	2	17	07 11 9963 034	13	5	2	07 11 9963 355	17	1	15
07 11 9932 710	74	5	22	07 11 9963 042	11	12	13	07 11 9963 355	17	2	33
07 11 9932 852	13	3	22	07 11 9963 042	13	5	6	07 11 9963 355	17	4	3
07 11 9932 852	13	4	19	07 11 9963 072	11	17	9	07 11 9963 417	27	7	7

V12 Engineering

www.bmwmarino.com

Teilenummern-Index  
 Part Number index  
 Index des numéros de pièces  
 Reservdelsnummer-Index  
 Indice dei numeri dei pezzi di ricambio

**00**  
**15**

4/86

D 150 / D 190 / D 530 / D 636

Teile-Nummer	HG	S	Nr.	Teile-Nummer	HG	S	Nr.	Teile-Nummer	HG	S	Nr.
07 11 9963 467	17	2	36	07 12 9922 417	13	8	12	11 11 1 331 627	11	9	16
07 11 9963 468	27	3	31	07 12 9922 426	11	21	17	11 11 1 331 628	11	9	16
07 11 9964 530	11	7	19	07 12 9922 426	11	22	12	11 11 1 331 629	11	9	16
07 11 9964 543	17	2	16	07 12 9922 426	27	14	8	11 11 1 331 684	11	15	27
07 11 9964 543	17	4	2	07 12 9922 426	27	16	7	11 11 1 331 684	11	16	4
07 11 9965 065	27	6	37	07 12 9922 430	27	14	5	11 11 1 331 684	11	2	14
07 11 9978 254	62	1	15	07 12 9922 714	27	10	2	11 11 1 331 731	11	13	16
07 11 9978 254	62	2	17	07 12 9922 714	74	5	30	11 11 1 333 859	11	2	9
07 11 9978 254	62	3	17	07 12 9934 959	74	2	20	11 11 1 333 864	11	13	16
07 11 9978 256	62	1	3	07 12 9952 104	11	5	15	11 11 1 761 848	11	2	6
07 11 9985 082	27	18	41	07 12 9952 111	13	8	4	11 11 1 763 362	11	3	2
07 11 9985 082	27	18	1	07 58 9 056 979	11	17	12	11 11 1 763 371	11	2	9
07 11 9985 082	27	9	7	07 58 9 056 979	11	18	15	11 11 1 763 683	11	2	9
07 11 9986 298	27	18	34	07 58 9 056 979	11	7	3	11 11 1 763 685	11	2	1
07 11 9986 298	27	6	30	07 58 9 056 979	13	4	23	11 12 1 331 660	11	4	9
07 11 9987 302	13	4	10	07 58 9 056 979	17	2	40	11 12 1 331 661	11	4	10
07 11 9987 844	74	2	8	07 58 9 056 979	17	7	18	11 12 1 331 662	11	4	3
07 11 9987 845	74	5	16	07 58 9 056 979	17	8	13	11 12 1 331 663	11	4	5
07 11 9999 050	74	1	8	07 58 9 056 979	27	7	6	11 12 1 331 664	11	4	6
07 11 9999 100	74	1	10	11 00 1 331 185	11	1	1	11 12 1 331 665	11	4	7
07 11 9999 117	74	1	7	11 00 1 761 350	11	1	2	11 12 1 331 666	11	4	8
07 11 9999 119	74	1	6	11 00 1 761 644	11	1	2	11 12 1 331 668	11	6	9
07 11 9999 141	74	1	11	11 00 1 763 682	11	1	2	11 12 1 331 669	11	6	9
07 12 9908 111	17	2	25	11 11 1 331 139	11	2	6	11 12 1 331 670	11	6	8
07 12 9908 132	17	2	32	11 11 1 331 600	11	2	1	11 12 1 331 671	11	6	1
07 12 9922 058	12	4	8	11 11 1 331 602	11	2	2	11 12 1 331 673	11	6	2
07 12 9922 058	12	5	11	11 11 1 331 603	11	2	4	11 12 1 331 674	11	6	3
07 12 9922 058	12	6	11	11 11 1 331 604	11	2	5	11 12 1 331 675	11	6	4
07 12 9922 058	12	7	11	11 11 1 331 605	11	3	1	11 12 1 331 676	11	6	5
07 12 9922 403	12	6	17	11 11 1 331 607	11	3	2	11 12 1 331 677	11	6	6
07 12 9922 403	12	7	17	11 11 1 331 608	11	3	2	11 12 1 331 678	11	6	7
07 12 9922 410	11	7	36	11 11 1 331 610	11	3	3	11 12 1 331 679	11	6	10
07 12 9922 410	13	4	8	11 11 1 331 611	11	3	4	11 12 1 331 680	11	6	12
07 12 9922 410	27	16	14	11 11 1 331 626	11	3	1	11 12 1 331 682	11	4	9

Teilenummern-Index  
 Part Number index  
 Index des numéros de pièces  
 Reservdelsnummer-Index  
 Indice dei numeri dei pezzi di ricambio

**00**  
**16**  
 4/86

D 150 / D 190 / D 530 / D 636

Teile-Nummer	HG	S	Nr.	Teile-Nummer	HG	S	Nr.	Teile-Nummer	HG	S	Nr.
11 12 1 331 683	11	4	10	11 13 1 333 862	11	7	7	11 21 1 331 644	11	9	7
11 12 1 331 687	11	6	13	11 13 1 763 597	11	7	1	11 21 1 331 647	11	9	8
11 12 1 331 688	11	6	14	11 13 1 763 694	11	7	2	11 21 1 331 649	11	9	11
11 12 1 331 689	11	5	6	11 13 1 763 762	11	7	1	11 21 1 331 650	11	2	10
11 12 1 331 689	11	6	15	11 14 1 331 210	11	8	10	11 21 1 331 651	11	2	11
11 12 1 331 690	11	5	5	11 14 1 331 211	11	8	18	11 21 1 331 652	11	9	12
11 12 1 331 690	11	6	16	11 14 1 331 212	11	8	4	11 21 1 331 654	11	9	14
11 12 1 331 691	11	6	17	11 14 1 331 615	11	8	1	11 21 1 331 655	11	9	15
11 12 1 331 692	11	6	18	11 14 1 331 616	11	8	2	11 21 1 761 038	11	9	13
11 12 1 331 693	11	6	24	11 14 1 331 617	11	8	3	11 21 1 763 387	11	2	13
11 12 1 333 860	11	4	18	11 14 1 331 618	11	8	8	11 21 1 763 388	11	2	15
11 12 1 763 214	11	6	9	11 14 1 331 619	11	10	6	11 21 1 763 389	11	20	20
11 12 1 763 377	11	4	17	11 14 1 331 619	11	8	9	11 21 1 763 695	11	9	1
11 12 1 763 381	11	4	18	11 14 1 331 620	11	8	13	11 22 1 331 695	11	10	1
11 12 1 763 562	11	4	9	11 14 1 331 621	11	8	14	11 22 1 331 697	11	10	10
11 12 1 763 563	11	4	10	11 14 1 331 622	11	8	16	11 22 1 331 698	11	10	11
11 12 1 763 564	11	4	5	11 14 1 331 623	11	8	17	11 22 1 331 699	11	10	12
11 12 1 763 692	11	4	2	11 14 1 761 801	11	8	27	11 22 1 331 701	11	10	13
11 12 1 763 764	11	4	18	11 15 1 285 638	11	5	12	11 22 1 331 702	11	10	14
11 12 1 763 765	11	5	9	11 15 1 285 797	11	5	11	11 22 1 331 703	11	10	7
11 12 1 763 766	11	5	1	11 15 1 763 774	11	5	16	11 23 1 331 704	11	8	21
11 12 1 763 766	11	5	3	11 21 1 331 209	11	9	10	11 23 1 331 705	11	8	22
11 12 1 763 768	11	5	2	11 21 1 331 625	11	9	1	11 23 1 331 706	11	8	23
11 12 1 763 769	11	5	18	11 21 1 331 631	11	9	2	11 23 1 331 707	11	8	24
11 12 1 763 770	11	5	17	11 21 1 331 632	11	9	2	11 23 1 331 708	11	8	15
11 12 1 763 771	11	5	8	11 21 1 331 633	11	9	2	11 23 1 763 565	11	8	21
11 12 1 763 772	11	5	4	11 21 1 331 635	11	9	3	11 24 1 331 712	11	11	2
11 12 1 763 773	11	5	7	11 21 1 331 636	11	9	3	11 24 1 331 713	11	11	3
11 12 1 763 779	11	5	10	11 21 1 331 637	11	9	3	11 24 1 331 715	11	11	4
11 12 1 763 791	11	5	4	11 21 1 331 639	11	9	4	11 24 1 331 716	11	11	4
11 12 1 763 972	11	5	19	11 21 1 331 640	11	9	4	11 24 1 331 717	11	11	4
11 13 1 331 612	11	7	1	11 21 1 331 641	11	9	4	11 24 1 761 174	11	11	1
11 13 1 331 613	11	7	2	11 21 1 331 642	11	9	5	11 24 1 761 175	11	11	1
11 13 1 333 862	11	7	25	11 21 1 331 643	11	9	6	11 24 1 761 176	11	11	1

V12 Engineering  
 www.bmwmarine.com

Teilenummern-Index  
 Part Number index  
 Index des numéros de pièces  
 Reservdelnummer-Index  
 Indice dei numeri dei pezzi di ricambio

00

17

4/86

D 150 / D 190 / D 530 / D 636

Teile-Nummer	HG	S	Nr.	Teile-Nummer	HG	S	Nr.	Teile-Nummer	HG	S	Nr.
1124 1761 177	11	11	1	1134 1331 753	11	4	14	1143 1763 595	11	7	33
1124 1761 178	11	11	1	1134 1331 754	11	4	15	1143 1763 596	11	7	34
1124 1763 238	11	11	1	1134 1331 755	11	4	16	1143 1763 600	11	7	16
1124 1763 239	11	11	1	1134 1763 395	11	4	1	1143 1763 699	11	7	16
1124 1763 240	11	11	1	1135 1333 400	11	13	8	1143 1763 776	11	7	30
1125 1331 718	11	11	5	1135 1333 402	11	13	9	1143 1763 840	11	7	32
1125 1331 720	11	11	8	1135 1333 404	11	13	10	1143 1763 923	11	7	35
1125 1331 724	11	11	6	1135 1333 881	11	13	7	1151 1333 435	11	14	1
1125 1331 725	11	11	7	1141 1333 406	11	13	12	1151 1333 437	11	14	3
1125 1331 726	11	11	5	1141 1333 412	11	13	13	1151 1333 438	11	14	8
1125 1331 727	11	11	8	1141 1333 413	11	7	11	1151 1333 439	11	14	9
1125 1763 391	11	11	5	1141 1333 414	11	7	8	1151 1333 440	11	14	10
1125 1763 393	11	11	6	1141 1333 415	11	7	9	1151 1333 441	11	14	4
1131 1331 733	11	13	2	1141 1333 416	11	7	12	1151 1761 147	11	14	17
1131 1331 734	11	13	1	1141 1333 417	11	7	14	1151 1761 182	11	14	12
1131 1331 735	11	13	3	1141 1763 601	11	7	11	1151 1761 182	74	3	1
1131 1331 736	11	13	4	1141 1763 697	11	7	11	1151 1763 297	11	14	18
1131 1763 394	11	13	1	1142 1333 423	11	12	12	1151 1763 298	11	14	19
1131 1763 696	11	13	1	1142 1333 424	11	12	15	1153 1250 399	17	2	22
1132 1331 737	11	12	11	1142 1763 698	11	12	12	1153 1266 470	74	4	10
1132 1331 738	11	12	10	1143 1331 175	11	7	28	1153 1326 498	17	2	3
1133 1331 739	11	12	1	1143 1333 425	11	7	15	1153 1326 523	17	4	18
1133 1331 740	11	12	18	1143 1333 426	11	7	16	1153 1326 523	17	9	3
1133 1331 741	11	12	2	1143 1333 428	11	7	17	1153 1326 638	11	6	21
1133 1331 742	11	12	3	1143 1333 431	11	7	21	1153 1326 638	13	6	3
1133 1331 745	11	12	4	1143 1333 432	11	7	38	1153 1326 638	17	4	31
1133 1331 746	11	12	8	1143 1333 433	11	7	25	1153 1326 638	74	4	14
1133 1331 748	11	12	7	1143 1761 663	11	7	20	1153 1326 638	74	5	14
1133 1331 749	11	12	5	1143 1761 921	11	7	30	1153 1326 639	17	4	14
1133 1333 863	11	12	6	1143 1761 922	11	7	31	1153 1326 639	17	5	3
1134 1331 199	11	4	1	1143 1763 384	11	7	6	1153 1326 639	17	6	4
1134 1331 750	11	4	12	1143 1763 492	11	16	19	1153 1326 639	27	13	14
1134 1331 751	11	4	11	1143 1763 527	11	7	35	1153 1326 639	74	4	8
1134 1331 752	11	4	13	1143 1763 594	11	7	32	1153 1326 809	17	2	23



Teilenummern-Index  
 Part Number index  
 Index des numéros de pièces  
 Reservdelsnummer-Index  
 Indice dei numeri dei pezzi di ricambio

**00**  

---

**18**  
 4/86

D 150 / D 190 / D 530 / D 636

Teile-Nummer	HG	S	Nr.	Teile-Nummer	HG	S	Nr.	Teile-Nummer	HG	S	Nr.
1153 1328 048	11	20	23	1162 1333 450	11	15	30	1165 1333 458	11	19	8
1153 1328 048	13	7	9	1162 1333 450	11	16	10	1165 1333 459	11	19	9
1153 1328 048	17	1	6	1162 1333 451	11	15	15	1165 1333 459	11	20	9
1153 1328 048	17	4	28	1162 1333 451	11	16	6	1165 1333 461	11	19	14
1153 1328 048	27	13	4	1162 1333 483	11	21	13	1165 1333 462	11	19	15
1153 1328 892	17	2	2	1162 1761 084	11	15	22	1165 1333 462	11	20	18
1153 1331 150	17	2	24	1162 1761 715	11	15	20	1165 1333 463	11	19	17
1153 1761 179	11	6	23	1162 1761 772	11	15	29	1165 1333 464	11	19	21
1153 1761 179	74	3	15	1162 1761 772	11	16	11	1165 1333 464	11	20	22
1153 1761 179	74	4	2	1162 1761 824	11	15	9	1165 1333 466	11	19	19
1161 1333 467	11	15	1	1162 1761 825	11	15	14	1165 1761 102	11	17	2
1161 1333 468	11	15	2	1162 1761 826	11	15	10	1165 1761 360	11	17	3
1161 1333 469	11	15	3	1162 1763 211	11	21	20	1165 1761 360	11	18	11
1161 1333 472	11	15	7	1162 1763 438	11	16	1	1165 1761 361	11	17	7
1161 1333 472	11	16	5	1162 1763 439	11	16	3	1165 1761 362	11	17	14
1162 1266 997	11	20	33	1162 1763 443	11	16	12	1165 1761 364	11	17	6
1162 1326 429	11	21	11	1162 1763 444	11	16	13	1165 1761 365	11	17	16
1162 1326 508	11	21	16	1162 1763 444	11	16	16	1165 1761 366	11	17	17
1162 1326 707	11	21	13	1162 1763 445	11	16	18	1165 1761 367	11	17	1
1162 1326 712	11	21	14	1162 1763 472	11	16	17	1165 1761 367	11	18	5
1162 1326 732	17	2	14	1162 1763 700	11	16	1	1165 1761 730	11	17	13
1162 1328 839	17	2	13	1165 1331 187	11	19	22	1165 1763 331	11	18	13
1162 1330 806	11	21	11	1165 1331 187	11	20	35	1165 1763 447	11	20	1
1162 1331 101	11	21	9	1165 1331 207	11	19	16	1165 1763 448	11	20	3
1162 1331 141	11	15	23	1165 1333 452	11	19	1	1165 1763 449	11	20	5
1162 1331 178	11	15	13	1165 1333 453	11	19	2	1165 1763 450	11	20	6
1162 1332 195	11	21	19	1165 1333 453	11	20	4	1165 1763 451	11	20	12
1162 1332 296	27	5	12	1165 1333 454	11	19	3	1165 1763 455	11	20	17
1162 1332 390	11	21	18	1165 1333 454	11	20	2	1165 1763 456	11	20	16
1162 1333 446	11	15	11	1165 1333 455	11	19	5	1165 1763 457	11	18	1
1162 1333 448	11	15	17	1165 1333 456	11	19	6	1165 1763 459	11	18	8
1162 1333 448	11	16	8	1165 1333 456	11	20	14	1165 1763 461	11	18	6
1162 1333 449	11	15	18	1165 1333 457	11	19	7	1165 1763 463	11	18	7
1162 1333 449	11	16	2	1165 1333 457	11	20	15	1165 1763 488	11	18	10

Teilenummern-Index  
 Part Number index  
 Index des numéros de pièces  
 Reservdelsnummer-Index  
 Indice dei numeri dei pezzi di ricambio

**00**  
**19**

4/86

D 150 / D 190 / D 530 / D 636

Teile-Nummer	HG	S	Nr.	Teile-Nummer	HG	S	Nr.	Teile-Nummer	HG	S	Nr.
1165 1763 701	11	20	1	1231 1329 282	12	1	16	1251 1334 064	12	6	14
1165 1763 702	11	18	1	1231 1333 477	12	1	5	1251 1334 064	12	7	14
1165 1763 705	11	18	5	1231 1333 479	12	1	7	1251 1334 070	12	5	1
1165 1763 778	11	20	16	1231 1333 480	12	1	8	1251 1334 302	12	6	1
1172 1261 404	74	3	6	1231 1333 934	12	1	13	1251 1334 305	12	6	2
1181 1326 474	21	1	6	1231 1333 937	12	2	2	1251 1334 310	12	6	1
1181 1326 477	21	1	18	1231 1333 939	12	2	8	1251 1334 495	12	7	2
1181 1326 478	21	1	2	1231 1333 943	12	1	12	1251 1764 011	12	7	1
1181 1326 533	21	1	4	1231 1333 944	12	2	7	1251 1764 012	12	7	1
1181 1326 813	21	1	7	1231 1334 010	12	2	3	1251 1764 115	12	7	16
1181 1328 821	21	1	8	1231 1334 011	12	2	4	1252 1331 942	12	4	2
1181 1328 858	21	1	9	1231 1334 012	12	2	5	1252 1333 922	12	4	12
1181 1329 348	21	1	16	1231 1334 013	12	2	6	1252 1334 181	12	5	1
1181 1330 557	21	1	5	1231 1334 335	12	1	12	1252 1334 183	12	5	1
1181 1331 177	11	22	4	1231 1761 690	12	1	13	1261 1329 961	12	4	17
1181 1333 460	11	22	4	1231 1761 869	12	1	13	1261 1331 979	12	4	16
1181 1333 473	11	22	i	1231 1763 365	12	2	10	1261 1333 976	11	2	13
1181 1333 894	11	22	9	1231 1763 465	12	1	5	1261 1333 996	12	4	18
1181 1761 146	11	22	5	1241 1333 980	12	3	1	1263 1329 960	12	4	10
1181 1761 146	27	14	9	1241 1334 377	12	3	4	1263 1329 960	12	5	7
1181 1761 279	21	1	1	1241 1334 378	12	3	5	1263 1334 306	12	6	7
1181 1761 559	11	19	4	1241 1334 379	12	3	6	1263 1334 306	12	7	7
1181 1761 616	11	22	8	1241 1334 380	12	3	7	1263 1334 392	12	6	4
1181 1761 617	11	22	10	1251 1331 976	12	4	1	1263 1334 392	12	7	4
1181 1763 304	11	22	9	1251 1331 978	12	4	15	1321 1326 574	13	3	32
1181 1763 304	27	14	6	1251 1331 978	12	6	16	1321 1326 574	13	4	14
1181 1763 916	11	22	13	1251 1333 979	12	1	14	1321 1326 574	27	16	11
1181 1763 917	11	22	13	1251 1334 050	12	5	15	1321 1328 524	27	16	10
12 12 1331 939	12	1	1	1251 1334 051	12	5	12	1321 1330 287	13	3	31
12 12 1331 940	12	1	2	1251 1334 051	12	6	12	1321 1330 287	13	4	13
12 12 1763 464	12	1	1	1251 1334 051	12	7	12	1321 1331 172	13	3	28
1231 1273 639	12	2	17	1251 1334 057	12	5	1	1321 1331 256	13	3	24
1231 1273 639	74	3	12	1251 1334 058	12	5	2	1321 1331 346	27	16	12
1231 1276 540	12	2	14	1251 1334 064	12	5	14	1321 1333 851	13	3	15

Teilenummern-Index  
 Part Number index  
 Index des numéros de pièces  
 Reservdelsnummer-Index  
 Indice dei numeri dei pezzi di ricambio

**00**  

---

**20**

4/86

D 150 / D 190 / D 530 / D 636

Teile-Nummer	HG	S	Nr.	Teile-Nummer	HG	S	Nr.	Teile-Nummer	HG	S	Nr.
13 21 1333 856	13	3	19	13 32 1761 553	13	1	1	13 53 1331 247	13	5	24
13 21 1333 856	13	4	15	13 32 1763 271	13	1	13	13 53 1331 248	13	5	25
13 21 1761 662	13	4	11	13 32 1763 598	13	1	1	13 53 1331 249	13	5	26
13 21 1761 672	13	3	18	13 51 1331 222	13	3	1	13 53 1331 250	13	3	36
13 21 1761 674	13	3	16	13 51 1331 223	13	3	4	13 53 1333 873	13	3	43
13 21 1761 674	13	4	20	13 51 1331 756	13	3	8	13 53 1333 874	13	3	34
13 21 1761 847	13	3	33	13 51 1333 870	13	3	5	13 53 1333 875	13	5	7
13 21 1761 847	13	4	6	13 51 1333 871	13	3	6	13 53 1761 163	13	5	4
13 21 1763 357	13	4	12	13 51 1761 167	13	3	2	13 53 1761 165	13	5	5
13 21 1763 441	13	4	5	13 51 1761 168	13	3	3	13 53 1761 166	13	5	14
13 21 1763 525	13	4	4	13 51 1761 168	13	4	3	13 53 1761 757	13	3	9
13 31 1263 264	11	20	29	13 51 1761 703	13	3	1	13 53 1761 758	13	3	10
13 31 1329 259	11	12	14	13 51 1763 466	13	4	1	13 53 1763 467	13	3	14
13 31 1331 217	13	2	13	13 51 1763 585	13	4	2	13 53 1763 709	13	5	31
13 31 1331 218	13	2	1	13 51 1763 618	13	3	44	13 53 1763 710	13	5	32
13 31 1331 219	13	2	4	13 51 1763 618	13	4	24	13 53 1763 711	13	5	33
13 31 1331 220	13	2	7	13 51 1763 706	13	4	1	13 53 1763 712	13	5	34
13 31 1331 221	13	2	8	13 52 1331 224	11	13	17	13 53 1763 713	13	5	35
13 31 1333 865	13	2	2	13 52 1331 225	13	3	42	13 53 1763 714	13	5	36
13 31 1333 866	13	2	3	13 53 1331 213	11	4	4	13 53 1763 716	13	5	37
13 31 1761 169	13	5	16	13 53 1331 226	13	5	1	13 53 1763 717	13	5	38
13 31 1761 170	13	2	9	13 53 1331 233	13	5	3	13 53 1763 718	13	5	30
13 31 1761 170	13	5	18	13 53 1331 234	13	5	9	13 54 1256 320	13	3	20
13 31 1761 554	13	1	7	13 53 1331 235	13	5	8	13 54 1256 320	13	4	16
13 31 1761 555	13	1	8	13 53 1331 236	13	5	10	13 71 1259 818	12	4	13
13 31 1763 210	13	1	14	13 53 1331 238	13	5	27	13 71 1761 575	13	7	1
13 31 1763 809	13	1	7	13 53 1331 239	13	5	28	13 71 1761 579	13	7	8
13 32 1331 215	13	2	14	13 53 1331 240	13	5	13	13 71 1761 579	13	8	5
13 32 1331 216	13	2	17	13 53 1331 241	13	5	29	13 71 1761 816	13	7	2
13 32 1331 251	13	2	20	13 53 1331 242	13	5	19	13 71 1761 817	13	7	3
13 32 1331 252	13	2	18	13 53 1331 243	13	5	20	13 71 1761 817	13	8	10
13 32 1333 869	13	2	19	13 53 1331 244	13	5	21	13 71 1761 820	13	7	5
13 32 1761 372	13	1	2	13 53 1331 245	13	5	22	13 71 1761 820	13	8	13
13 32 1761 373	13	1	3	13 53 1331 246	13	5	23	13 71 1763 253	13	8	1

Teilenummern-Index  
 Part Number index  
 Index des numéros de pièces  
 Reservdelsnummer-Index  
 Indice dei numeri dei pezzi di ricambio

**00**  
**21**  
 4/86

D 150 / D 190 / D 530 / D 636

Teile-Nummer	HG	S	Nr.	Teile-Nummer	HG	S	Nr.	Teile-Nummer	HG	S	Nr.
13 71 1 763 323	13	8	9	17 11 1 332 596	17	8	19	17 11 1 761 885	17	2	1
13 71 1 763 325	13	8	7	17 11 1 332 597	17	8	15	17 11 1 763 221	17	2	42
13 71 1 763 328	13	8	8	17 11 1 332 598	17	8	9	17 11 1 763 262	11	17	10
13 71 1 763 523	13	8	6	17 11 1 332 599	17	8	10	17 11 1 763 264	17	2	41
13 72 1 331 128	13	6	1	17 11 1 332 600	17	8	8	17 11 1 763 277	17	3	5
13 72 1 331 203	13	6	2	17 11 1 332 601	17	8	18	17 11 1 763 288	17	2	6
13 72 1 761 729	11	6	22	17 11 1 332 602	17	8	6	17 11 1 763 293	17	2	6
13 72 1 761 759	11	6	20	17 11 1 332 603	17	8	7	17 11 1 763 299	17	2	39
13 72 1 763 212	11	6	19	17 11 1 332 604	17	8	11	17 11 1 763 303	17	2	43
13 72 1 763 278	13	8	3	17 11 1 332 606	17	8	4	17 11 1 763 334	17	2	1
13 72 1 763 508	13	8	3	17 11 1 332 607	17	8	3	17 11 1 763 473	17	3	1
16 12 1 119 240	13	1	12	17 11 1 332 608	17	8	2	17 12 1 331 112	17	4	13
17 11 1 326 537	17	7	14	17 11 1 332 620	17	8	20	17 12 1 331 113	17	4	15
17 11 1 328 126	17	7	6	17 11 1 333 847	17	7	2	17 12 1 331 113	17	5	10
17 11 1 328 301	17	7	3	17 11 1 333 848	17	7	11	17 12 1 331 113	17	6	2
17 11 1 328 302	17	7	7	17 11 1 333 849	17	7	15	17 12 1 331 142	17	1	7
17 11 1 328 307	17	7	8	17 11 1 333 850	17	7	5	17 12 1 331 154	17	4	22
17 11 1 328 308	17	7	9	17 11 1 333 850	17	8	5	17 12 1 331 155	17	4	24
17 11 1 328 310	17	7	16	17 11 1 333 878	17	9	4	17 12 1 331 157	17	4	21
17 11 1 328 312	17	7	4	17 11 1 333 880	17	9	5	17 12 1 331 158	17	4	23
17 11 1 330 113	17	7	10	17 11 1 333 883	17	4	9	17 12 1 331 159	17	4	20
17 11 1 331 132	17	2	10	17 11 1 761 002	17	2	1	17 12 1 331 161	17	4	29
17 11 1 331 134	17	2	9	17 11 1 761 076	17	2	9	17 12 1 331 163	17	4	12
17 11 1 331 135	17	2	19	17 11 1 761 082	17	2	10	17 12 1 331 197	17	1	5
17 11 1 331 156	17	4	25	17 11 1 761 083	11	15	21	17 12 1 331 204	17	1	2
17 11 1 331 164	17	4	16	17 11 1 761 107	17	9	6	17 12 1 331 205	17	1	8
17 11 1 331 190	17	2	8	17 11 1 761 108	17	9	7	17 12 1 333 484	17	4	27
17 11 1 331 196	17	7	1	17 11 1 761 171	17	2	7	17 12 1 761 097	17	1	1
17 11 1 331 257	17	9	1	17 11 1 761 273	11	20	24	17 12 1 761 119	17	5	1
17 11 1 331 258	17	9	2	17 11 1 761 273	11	20	34	17 12 1 761 120	17	5	2
17 11 1 331 259	17	7	17	17 11 1 761 273	17	2	13	17 12 1 761 121	17	5	8
17 11 1 332 533	17	8	1	17 11 1 761 273	17	7	13	17 12 1 761 122	17	5	6
17 11 1 332 593	17	8	17	17 11 1 761 273	17	8	14	17 12 1 761 124	17	5	4
17 11 1 332 595	17	8	16	17 11 1 761 884	17	2	10	17 12 1 761 125	17	5	5

V12 Engineering  
 www.bmwmarine.com

Teilenummern-Index  
 Part Number index  
 Index des numéros de pièces  
 Reservdelsnummer-Index  
 Indice dei numeri dei pezzi di ricambio

**00**  
**22**

4/86

D 150 / D 190 / D 530 / D 636

Teile-Nummer	HG	S	Nr.	Teile-Nummer	HG	S	Nr.	Teile-Nummer	HG	S	Nr.
17 12 1761 289	17	1	10	17 21 1761 376	27	13	2	23 71 1763 889	27	15	14
17 12 1761 354	17	4	30	17 22 1331 137	17	2	37	23 71 1763 890	27	15	14
17 12 1761 375	27	13	3	17 22 1331 151	17	4	6	23 71 1763 909	27	15	13
17 12 1761 379	17	4	21	17 22 1331 152	17	2	15	26 11 1328 678	21	1	17
17 12 1761 380	17	4	22	17 22 1331 165	17	2	20	26 11 1332 270	21	1	17
17 12 1761 418	17	1	13	17 22 1331 192	17	2	21	27 62 1326 896	27	12	3
17 12 1761 583	17	5	18	17 22 1331 195	17	4	4	27 62 1326 897	27	12	1
17 12 1761 583	17	6	11	17 22 1331 206	17	2	17	27 62 1328 130	27	6	2
17 12 1761 584	17	5	19	17 22 1761 339	17	4	8	27 62 1328 131	27	8	31
17 12 1761 585	17	5	16	17 22 1761 340	17	4	7	27 62 1328 132	27	8	30
17 12 1761 586	17	5	9	17 22 1763 296	17	2	17	27 62 1328 133	27	9	17
17 12 1761 587	27	13	13	17 22 1763 336	17	2	21	27 62 1328 136	27	8	21
17 12 1761 588	17	5	17	18 11 1331 173	11	20	31	27 62 1328 137	27	8	22
17 12 1761 589	17	5	20	18 11 1331 173	11	21	15	27 62 1328 138	27	8	27
17 12 1761 589	17	6	10	18 11 1331 174	11	21	8	27 62 1328 139	27	9	16
17 12 1763 229	17	6	6	18 11 1333 485	11	21	4	27 62 1328 142	27	9	19
17 12 1763 230	17	6	5	18 11 1761 384	11	21	2	27 62 1328 147	27	6	41
17 12 1763 231	17	6	7	18 11 1761 385	11	21	1	27 62 1328 148	27	6	41
17 12 1763 244	11	20	25	18 11 1763 206	11	20	30	27 62 1328 149	27	6	41
17 12 1763 295	17	4	27	18 11 1763 218	11	21	12	27 62 1328 150	27	6	41
17 12 1763 335	17	2	31	18 11 1763 219	11	21	21	27 62 1328 151	27	6	41
17 12 1763 335	17	5	12	18 11 1763 273	11	20	32	27 62 1328 152	27	6	40
17 12 1763 335	17	6	3	21 21 1761 008	21	1	14	27 62 1328 153	27	6	40
17 12 1763 353	11	20	28	21 21 1761 771	21	1	14	27 62 1328 154	27	6	40
17 12 1763 471	17	1	16	23 71 1333 897	27	15	19	27 62 1328 155	27	6	40
17 12 1763 504	17	6	1	23 71 1761 386	27	14	2	27 62 1328 156	27	6	40
17 12 1763 719	17	5	9	23 71 1761 388	27	14	1	27 62 1328 162	27	18	30
17 12 1763 722	17	6	6	23 71 1761 389	27	14	3	27 62 1328 162	27	6	27
17 12 1763 723	11	20	25	23 71 1761 620	27	14	2	27 62 1328 163	27	7	12
17 12 1763 724	17	1	1	23 71 1761 621	27	14	1	27 62 1328 166	27	7	13
17 12 1763 810	17	6	1	23 71 1763 869	27	15	1	27 62 1328 168	27	7	10
17 21 1331 148	17	4	1	23 71 1763 870	27	15	4	27 62 1328 169	27	7	14
17 21 1331 189	17	2	18	23 71 1763 874	27	15	7	27 62 1328 170	27	7	22
17 21 1761 077	17	2	19	23 71 1763 877	27	15	10	27 62 1328 171	27	7	11

V12 Engineering  
 www.bmwmarine.com

Teilenummern-Index  
 Part Number index  
 Index des numéros de pièces  
 Reservdelnummer-Index  
 Indice dei numeri dei pezzi di ricambio

**00**  
**23**  
 4/86

D 150 / D 190 / D 530 / D 636

Teile-Nummer	HG	S	Nr.	Teile-Nummer	HG	S	Nr.	Teile-Nummer	HG	S	Nr.
27 62 1 328 173	27	6	5	27 62 1 328 206	27	6	31	27 62 1 328 260	27	3	32
27 62 1 328 173	27	8	7	27 62 1 328 207	27	6	25	27 62 1 328 262	27	3	6
27 62 1 328 174	27	18	26	27 62 1 328 208	27	6	23	27 62 1 328 263	27	3	2
27 62 1 328 174	27	6	36	27 62 1 328 209	27	7	27	27 62 1 328 267	27	3	21
27 62 1 328 175	27	18	26	27 62 1 328 210	27	7	27	27 62 1 328 273	27	3	18
27 62 1 328 175	27	6	36	27 62 1 328 211	27	7	27	27 62 1 328 275	27	3	12
27 62 1 328 176	27	18	26	27 62 1 328 212	27	7	27	27 62 1 328 276	27	3	29
27 62 1 328 176	27	6	36	27 62 1 328 217	27	9	3	27 62 1 328 277	27	3	36
27 62 1 328 177	27	18	26	27 62 1 328 218	27	9	3	27 62 1 328 278	27	6	42
27 62 1 328 177	27	6	36	27 62 1 328 219	27	9	3	27 62 1 328 279	27	3	30
27 62 1 328 178	27	18	25	27 62 1 328 220	27	9	3	27 62 1 328 281	27	3	24
27 62 1 328 179	27	6	21	27 62 1 328 221	27	9	3	27 62 1 328 282	27	3	26
27 62 1 328 180	27	6	29	27 62 1 328 222	27	18	6	27 62 1 328 283	27	3	20
27 62 1 328 181	27	18	18	27 62 1 328 222	27	9	9	27 62 1 328 330	27	12	4
27 62 1 328 181	27	6	13	27 62 1 328 223	27	18	6	27 62 1 328 332	27	12	2
27 62 1 328 182	27	6	18	27 62 1 328 223	27	9	9	27 62 1 328 378	27	6	11
27 62 1 328 183	27	6	12	27 62 1 328 224	27	18	6	27 62 1 328 379	27	6	11
27 62 1 328 187	27	6	9	27 62 1 328 224	27	9	9	27 62 1 328 382	27	8	28
27 62 1 328 190	27	6	11	27 62 1 328 225	27	18	6	27 62 1 328 385	27	6	6
27 62 1 328 191	27	6	11	27 62 1 328 225	27	9	9	27 62 1 328 387	27	6	20
27 62 1 328 192	27	6	11	27 62 1 328 226	27	18	6	27 62 1 328 389	27	18	2
27 62 1 328 193	27	6	11	27 62 1 328 226	27	9	9	27 62 1 328 389	27	6	7
27 62 1 328 194	27	6	11	27 62 1 328 233	27	8	19	27 62 1 328 390	27	18	1
27 62 1 328 195	27	6	11	27 62 1 328 234	27	9	10	27 62 1 328 390	27	6	8
27 62 1 328 196	27	7	32	27 62 1 328 238	27	8	11	27 62 1 328 391	27	18	13
27 62 1 328 199	27	6	10	27 62 1 328 239	27	8	4	27 62 1 328 391	27	6	33
27 62 1 328 200	27	6	15	27 62 1 328 241	27	8	12	27 62 1 328 392	27	6	34
27 62 1 328 202	27	18	29	27 62 1 328 243	27	9	6	27 62 1 328 393	27	7	29
27 62 1 328 202	27	6	26	27 62 1 328 244	27	9	5	27 62 1 328 394	27	7	30
27 62 1 328 203	27	18	32	27 62 1 328 248	27	8	25	27 62 1 328 395	27	7	25
27 62 1 328 203	27	6	28	27 62 1 328 249	27	3	35	27 62 1 328 396	27	7	26
27 62 1 328 204	27	6	32	27 62 1 328 249	27	8	44	27 62 1 328 398	27	7	31
27 62 1 328 205	27	18	31	27 62 1 328 249	27	8	47	27 62 1 328 400	27	6	38
27 62 1 328 205	27	6	24	27 62 1 328 259	27	3	16	27 62 1 328 400	27	7	24

Teilenummern-Index  
 Part Number index  
 Index des numéros de pièces  
 Reservdelsnummer-Index  
 Indice dei numeri dei pezzi di ricambio

**00**  

---

**24**

4/86

D 150 / D 190 / D 530 / D 636

Teile-Nummer	HG	S	Nr.	Teile-Nummer	HG	S	Nr.	Teile-Nummer	HG	S	Nr.
27 62 1 328 402	27	8	18	27 62 1 328 882	27	4	1	27 62 1 330 596	27	7	18
27 62 1 328 403	27	8	24	27 62 1 328 910	27	9	4	27 62 1 330 598	27	8	34
27 62 1 328 404	27	9	2	27 62 1 328 985	27	8	33	27 62 1 330 599	27	9	30
27 62 1 328 406	27	8	35	27 62 1 328 986	27	8	33	27 62 1 330 600	27	9	33
27 62 1 328 407	27	8	14	27 62 1 328 987	27	8	33	27 62 1 330 601	27	9	23
27 62 1 328 408	27	18	13	27 62 1 328 988	27	8	33	27 62 1 330 601	27	9	37
27 62 1 328 408	27	8	6	27 62 1 328 989	27	8	33	27 62 1 330 602	27	18	17
27 62 1 328 409	27	18	14	27 62 1 328 992	27	6	19	27 62 1 330 602	27	6	14
27 62 1 328 409	27	8	5	27 62 1 330 032	27	8	1	27 62 1 330 604	27	9	21
27 62 1 328 411	27	9	8	27 62 1 330 033	27	6	1	27 62 1 330 605	27	8	41
27 62 1 328 412	27	9	1	27 62 1 330 059	27	7	1	27 62 1 330 607	27	8	46
27 62 1 328 413	27	8	26	27 62 1 330 060	27	7	5	27 62 1 330 608	27	7	33
27 62 1 328 414	27	8	3	27 62 1 330 061	27	6	39	27 62 1 330 618	27	6	44
27 62 1 328 415	27	8	15	27 62 1 330 062	27	8	23	27 62 1 330 743	27	7	17
27 62 1 328 416	27	3	7	27 62 1 330 063	27	9	11	27 62 1 330 750	27	6	35
27 62 1 328 418	27	3	3	27 62 1 330 064	27	3	1	27 62 1 330 751	27	9	24
27 62 1 328 419	27	3	14	27 62 1 330 065	27	3	17	27 62 1 330 752	27	6	44
27 62 1 328 579	27	8	37	27 62 1 330 066	27	3	34	27 62 1 330 827	27	6	1
27 62 1 328 588	27	8	38	27 62 1 330 067	27	8	2	27 62 1 330 828	27	8	1
27 62 1 328 590	27	3	9	27 62 1 330 068	27	7	28	27 62 1 330 840	27	2	8
27 62 1 328 595	27	3	13	27 62 1 330 118	27	8	10	27 62 1 330 845	27	2	3
27 62 1 328 596	27	3	8	27 62 1 330 282	27	8	20	27 62 1 330 846	27	2	9
27 62 1 328 620	27	4	2	27 62 1 330 382	27	3	33	27 62 1 330 849	27	2	4
27 62 1 328 621	27	4	5	27 62 1 330 452	27	7	8	27 62 1 330 855	27	1	3
27 62 1 328 623	27	4	3	27 62 1 330 546	27	12	7	27 62 1 330 855	27	2	7
27 62 1 328 624	27	4	4	27 62 1 330 546	27	8	36	27 62 1 330 859	27	2	6
27 62 1 328 711	27	6	11	27 62 1 330 546	27	9	36	27 62 1 330 929	27	2	2
27 62 1 328 712	27	6	11	27 62 1 330 568	27	6	35	27 62 1 330 932	27	2	1
27 62 1 328 832	27	12	8	27 62 1 330 580	27	8	42	27 62 1 330 977	27	2	5
27 62 1 328 835	27	3	23	27 62 1 330 582	27	9	22	27 62 1 330 981	27	12	10
27 62 1 328 843	27	8	13	27 62 1 330 583	27	9	32	27 62 1 330 999	27	9	25
27 62 1 328 844	27	8	13	27 62 1 330 584	27	9	29	27 62 1 332 072	27	6	16
27 62 1 328 845	27	8	13	27 62 1 330 585	27	9	31	27 62 1 332 073	27	6	17
27 62 1 328 846	27	8	13	27 62 1 330 586	27	9	27	27 62 1 332 143	27	3	15

V12 Engineering  
 www.bmwmarine.com

Teilenummern-Index  
 Part Number index  
 Index des numéros de pièces  
 Reservdelnummer-Index  
 Indice dei numeri dei pezzi di ricambio

**00**  
**25**

4/86

D 150 / D 190 / D 530 / D 636

Teile-Nummer	HG	S	Nr.	Teile-Nummer	HG	S	Nr.	Teile-Nummer	HG	S	Nr.
27 62 1 332 150	27	3	22	27 63 1 331 262	27	17	10	27 63 1 761 950	27	18	50
27 62 1 332 151	27	3	25	27 63 1 331 264	27	17	20	27 63 1 761 951	27	17	22
27 62 1 332 152	27	3	19	27 63 1 331 265	27	17	17	27 63 1 761 952	27	17	8
27 62 1 332 271	27	6	44	27 63 1 331 270	27	17	18	27 63 1 761 953	27	18	8
27 62 1 332 282	27	1	1	27 63 1 331 271	27	17	14	27 63 1 761 954	27	18	11
27 62 1 332 283	27	1	2	27 63 1 333 793	27	16	3	27 63 1 761 955	27	18	11
27 62 1 332 299	27	5	4	27 63 1 761 015	27	18	41	27 63 1 761 956	27	18	11
27 62 1 332 307	27	5	11	27 63 1 761 015	27	18	5	27 63 1 761 957	27	18	11
27 62 1 332 361	27	7	40	27 63 1 761 065	27	17	1	27 63 1 761 958	27	18	11
27 62 1 332 364	27	9	4	27 63 1 761 066	27	17	2	27 63 1 761 959	27	18	4
27 62 1 332 365	27	8	45	27 63 1 761 067	27	18	4	27 63 1 761 960	27	18	4
27 62 1 332 366	27	1	5	27 63 1 761 068	27	18	4	27 63 1 761 961	27	18	4
27 62 1 332 370	27	7	39	27 63 1 761 069	27	18	4	27 63 1 761 962	27	18	6
27 62 1 332 371	27	7	35	27 63 1 761 077	27	18	47	27 63 1 761 963	27	18	6
27 62 1 332 372	27	7	36	27 63 1 761 106	27	16	4	27 63 1 761 964	27	18	6
27 62 1 332 373	27	7	38	27 63 1 761 463	27	18	42	27 63 1 761 965	27	18	6
27 62 1 332 374	27	7	17	27 63 1 761 489	27	17	9	27 63 1 761 966	27	18	6
27 62 1 332 375	27	6	32	27 63 1 761 668	27	16	8	27 63 1 761 967	27	18	9
27 62 1 332 376	27	6	31	27 63 1 761 776	27	16	1	27 63 1 761 968	27	18	9
27 62 1 332 377	27	6	23	27 63 1 761 777	27	16	1	27 63 1 761 969	27	18	9
27 62 1 332 378	27	6	24	27 63 1 761 778	27	16	1	27 63 1 761 970	27	18	16
27 62 1 332 393	27	5	1	27 63 1 761 919	27	13	10	27 63 1 761 971	27	18	40
27 62 1 332 394	27	1	4	27 63 1 761 933	27	17	1	27 63 1 761 972	27	18	40
27 62 1 332 395	27	7	41	27 63 1 761 934	27	17	2	27 63 1 761 973	27	18	40
27 62 1 332 418	27	6	22	27 63 1 761 935	27	17	3	27 63 1 761 974	27	18	12
27 62 1 332 678	27	12	11	27 63 1 761 936	27	18	48	27 63 1 761 975	27	18	20
27 62 1 332 679	27	12	9	27 63 1 761 938	27	17	4	27 63 1 761 976	27	18	37
27 62 1 332 680	27	5	11	27 63 1 761 939	27	18	36	27 63 1 761 977	27	18	21
27 62 1 332 681	27	5	13	27 63 1 761 940	27	18	36	27 63 1 761 978	27	18	23
27 62 1 332 720	27	1	5	27 63 1 761 944	27	18	44	27 63 1 761 979	27	18	35
27 62 1 334 313	27	5	2	27 63 1 761 946	27	18	42	27 63 1 761 980	27	18	33
27 63 1 326 972	27	13	1	27 63 1 761 947	27	18	38	27 63 1 761 981	27	18	39
27 63 1 330 744	27	13	12	27 63 1 761 948	27	18	47	27 63 1 761 982	27	18	19
27 63 1 330 753	27	13	11	27 63 1 761 949	27	18	49	27 63 1 761 983	27	18	22



Teilenummern-Index  
 Part Number index  
 Index des numéros de pièces  
 Reservdelsnummer-Index  
 Indice dei numeri dei pezzi di ricambio

**00**  

---

**26**

4/86

D 150 / D 190 / D 530 / D 636

Teile-Nummer	HG	S	Nr.	Teile-Nummer	HG	S	Nr.	Teile-Nummer	HG	S	Nr.
27 63 1 761 984	27	18	15	27 63 1 763 026	27	18	33	27 63 1 763 554	27	16	1
27 63 1 761 985	27	18	28	27 63 1 763 027	27	18	39	27 63 1 763 555	27	16	1
27 63 1 761 986	27	17	15	27 63 1 763 028	27	18	19	27 63 1 763 556	27	16	1
27 63 1 761 987	27	18	45	27 63 1 763 030	27	18	14	27 64 1 326 546	12	4	6
27 63 1 761 988	27	18	27	27 63 1 763 033	27	17	22	27 64 1 326 546	12	5	9
27 63 1 761 989	27	18	24	27 63 1 763 034	27	18	28	27 64 1 326 546	12	6	9
27 63 1 761 990	27	17	13	27 63 1 763 070	27	18	8	27 64 1 326 546	12	7	9
27 63 1 761 991	27	18	43	27 63 1 763 071	27	18	9	27 64 1 326 911	27	10	4
27 63 1 761 992	27	18	3	27 63 1 763 072	27	18	9	27 64 1 326 967	27	3	39
27 63 1 761 993	27	17	7	27 63 1 763 073	27	18	9	27 64 1 328 054	27	7	20
27 63 1 761 994	27	18	5	27 63 1 763 074	27	18	10	27 64 1 328 773	27	10	1
27 63 1 761 995	27	18	10	27 63 1 763 075	27	18	7	27 64 1 330 482	27	11	8
27 63 1 761 996	27	18	7	27 63 1 763 076	27	18	49	27 64 1 334 177	27	11	2
27 63 1 761 997	27	17	1	27 63 1 763 076	27	18	54	27 64 1 334 178	27	11	1
27 63 1 761 998	27	17	2	27 63 1 763 078	27	18	53	27 64 1 334 426	27	11	3
27 63 1 763 005	27	18	38	27 63 1 763 080	27	18	55	27 64 1 334 427	27	11	4
27 63 1 763 006	27	18	8	27 63 1 763 081	27	18	52	27 64 1 334 428	27	11	5
27 63 1 763 007	27	18	11	27 63 1 763 082	27	18	52	27 64 1 334 429	27	11	6
27 63 1 763 008	27	18	11	27 63 1 763 084	27	18	52	27 64 1 334 430	27	11	7
27 63 1 763 009	27	18	11	27 63 1 763 085	27	17	7	27 64 1 334 431	27	11	9
27 63 1 763 010	27	18	11	27 63 1 763 085	27	18	52	27 64 1 334 432	27	11	10
27 63 1 763 012	27	18	4	27 63 1 763 086	27	18	11	27 64 1 334 433	27	11	11
27 63 1 763 013	27	18	4	27 63 1 763 087	27	18	11	27 64 1 334 434	27	11	12
27 63 1 763 014	27	18	4	27 63 1 763 088	27	18	11	27 64 1 334 435	27	11	13
27 63 1 763 016	27	18	9	27 63 1 763 089	27	18	11	27 64 1 334 436	27	11	14
27 63 1 763 017	27	18	9	27 63 1 763 222	27	18	46	32 31 1 108 620	74	3	7
27 63 1 763 018	27	18	9	27 63 1 763 223	27	18	46	32 41 1 117 181	11	7	18
27 63 1 763 019	27	18	10	27 63 1 763 224	27	18	46	32 41 1 117 181	13	1	10
27 63 1 763 020	27	18	7	27 63 1 763 225	27	18	46	32 41 1 124 680	74	4	3
27 63 1 763 021	27	18	16	27 63 1 763 226	27	18	46	32 41 1 277 375	74	3	11
27 63 1 763 022	27	18	40	27 63 1 763 507	27	13	5	46 63 1 233 200	12	4	11
27 63 1 763 023	27	18	40	27 63 1 763 547	27	16	1	51 91 1 330 467	51	1	1
27 63 1 763 024	27	18	40	27 63 1 763 548	27	16	1	51 91 1 330 468	51	1	2
27 63 1 763 025	27	18	35	27 63 1 763 549	27	16	1	51 91 1 330 469	51	1	3

Teilenummern-Index  
 Part Number index  
 Index des numéros de pièces  
 Reservdelnummer-Index  
 Indice dei numeri dei pezzi di ricambio

**00**  
**27**  
 4/86

D 150 / D 190 / D 530 / D 636

Teile-Nummer	HG	S	Nr.	Teile-Nummer	HG	S	Nr.	Teile-Nummer	HG	S	Nr.
51 91 1330 470	51	1	4	61 13 1354 092	74	5	15	61 31 1334 407	62	3	3
51 91 1330 471	51	1	5	61 31 1243 490	62	1	22	61 31 1334 408	62	2	3
51 91 1330 481	51	1	7	61 31 1331 910	62	1	11	61 31 1334 408	62	3	3
51 91 1330 502	51	1	6	61 31 1333 903	62	1	13	61 31 1334 409	62	2	3
61 10 1331 949	62	1	10	61 31 1333 992	62	1	31	61 31 1334 409	62	3	3
61 11 1331 985	62	1	26	61 31 1333 992	62	2	30	61 31 1334 410	62	2	3
61 11 1331 995	62	1	24	61 31 1333 992	62	3	30	61 31 1334 410	62	3	3
61 11 1334 053	62	1	26	61 31 1333 993	62	1	32	61 31 1334 411	62	2	3
61 11 1334 098	62	2	4	61 31 1333 993	62	2	31	61 31 1334 411	62	3	3
61 11 1334 122	62	2	21	61 31 1333 993	62	3	31	61 31 1334 412	62	2	3
61 11 1334 133	62	2	26	61 31 1334 110	62	2	12	61 31 1334 412	62	3	3
61 11 1334 209	62	2	32	61 31 1334 110	62	3	12	61 31 1334 413	62	2	3
61 11 1334 303	62	2	4	61 31 1334 113	62	2	13	61 31 1334 413	62	3	3
61 11 1764 014	62	3	21	61 31 1334 113	62	3	13	61 31 1334 414	62	2	3
61 11 1764 014	62	3	26	61 31 1334 114	62	2	14	61 31 1334 414	62	3	3
61 11 1764 019	62	3	5	61 31 1334 114	62	3	14	61 31 1334 415	62	2	3
61 11 1764 110	62	3	4	61 31 1334 117	62	2	15	61 31 1334 415	62	3	3
61 13 1328 974	62	1	8	61 31 1334 117	62	3	15	61 31 1334 416	62	2	3
61 13 1329 977	12	4	4	61 31 1334 372	12	6	8	61 31 1334 416	62	3	3
61 13 1329 977	12	5	4	61 31 1334 372	12	7	8	61 31 1334 417	62	2	3
61 13 1329 978	12	4	3	61 31 1334 372	62	2	5	61 31 1334 417	62	3	3
61 13 1329 978	12	5	3	61 31 1334 401	62	2	3	61 31 1334 418	62	2	3
61 13 1329 978	12	6	3	61 31 1334 401	62	3	3	61 31 1334 418	62	3	3
61 13 1329 978	12	7	3	61 31 1334 402	62	2	3	61 31 1334 419	62	2	3
61 13 1331 916	62	1	9	61 31 1334 402	62	3	3	61 31 1334 419	62	3	3
61 13 1333 902	62	1	12	61 31 1334 403	62	2	3	61 31 1334 420	62	2	3
61 13 1334 039	62	1	35	61 31 1334 403	62	3	3	61 31 1334 420	62	3	3
61 13 1334 040	62	1	36	61 31 1334 404	62	2	3	61 31 1334 421	62	2	3
61 13 1334 153	62	2	20	61 31 1334 404	62	3	3	61 31 1334 421	62	3	3
61 13 1334 153	62	3	20	61 31 1334 405	62	2	3	61 31 1334 422	62	2	3
61 13 1334 307	62	2	7	61 31 1334 405	62	3	3	61 31 1334 422	62	3	3
61 13 1334 307	62	3	7	61 31 1334 406	62	2	3	61 31 1334 423	62	2	3
61 13 1334 308	62	2	8	61 31 1334 406	62	3	3	61 31 1334 423	62	3	3
61 13 1334 308	62	3	8	61 31 1334 407	62	2	3	61 31 1334 424	62	2	3

V12 Engineering  
 www.bmwmarine.com

Teilenummern-Index  
 Part Number index  
 Index des numéros de pièces  
 Reservdelsnummer-Index  
 Indice dei numeri dei pezzi di ricambio

**00**  

---

**28**  
 4/86

D 150 / D 190 / D 530 / D 636

Teile-Nummer	HG	S	Nr.	Teile-Nummer	HG	S	Nr.	Teile-Nummer	HG	S	Nr.
61 31 1 334 424	62	3	3	62 11 1 334 216	62	3	27	62 16 1 334 489	62	3	33
61 31 1 334 425	62	2	3	62 11 1 764 017	62	3	32	71 11 1 103 086	74	1	5
61 31 1 334 425	62	3	3	62 13 1 331 963	62	1	14	71 11 9 092 709	74	1	9
61 31 1 373 586	12	5	8	62 13 1 331 965	62	1	16	74 51 1 331 003	74	1	2
61 31 1 373 586	62	2	5	62 13 1 331 967	62	1	18	74 51 1 331 552	74	1	12
61 32 1 331 960	62	1	4	62 13 1 331 969	62	1	19	74 51 1 331 553	74	1	1
61 32 1 331 971	62	1	5	62 13 1 331 970	62	1	17	74 51 1 333 567	74	1	3
61 32 1 331 972	62	1	6	62 13 1 331 973	62	1	30	74 92 1 332 067	74	2	4
61 32 1 333 975	62	1	7	62 13 1 331 989	62	1	20	74 92 1 332 077	74	2	24
62 10 1 331 981	62	1	1	62 13 1 331 991	62	1	21	74 92 1 332 235	74	2	12
62 10 1 334 052	62	1	1	62 13 1 331 998	62	1	29	74 92 1 332 235	74	5	13
62 10 1 334 066	62	1	1	62 13 1 333 924	62	1	34	74 92 1 332 236	74	2	23
62 10 1 334 091	62	2	1	62 13 1 334 118	62	2	16	74 92 1 332 237	74	2	11
62 10 1 334 143	62	2	1	62 13 1 334 120	62	2	18	74 92 1 332 314	74	2	7
62 10 1 334 320	62	2	1	62 13 1 334 120	62	3	18	74 92 1 332 315	74	2	6
62 10 1 334 343	62	2	1	62 13 1 334 121	62	2	19	74 92 1 332 333	74	5	11
62 10 1 764 111	62	3	1	62 13 1 334 121	62	3	19	74 92 1 332 335	74	5	37
62 10 1 764 112	62	3	1	62 13 1 334 126	62	2	25	74 92 1 332 338	74	5	33
62 11 1 331 987	62	1	25	62 13 1 334 359	62	2	16	74 92 1 332 417	74	2	16
62 11 1 331 996	62	1	27	62 13 1 334 359	62	3	16	74 92 1 332 417	74	5	21
62 11 1 331 997	62	1	28	62 14 1 334 101	62	2	9	74 92 1 332 429	74	2	21
62 11 1 334 065	62	1	25	62 14 1 334 103	62	3	34	74 92 1 332 429	74	5	20
62 11 1 334 100	62	2	6	62 14 1 334 105	62	2	10	74 92 1 332 430	74	2	22
62 11 1 334 100	62	3	6	62 14 1 334 106	62	2	11	74 92 1 332 475	74	5	32
62 11 1 334 124	62	2	23	62 14 1 334 326	62	2	9	74 92 1 332 478	74	5	35
62 11 1 334 124	62	3	23	62 14 1 334 326	62	3	9	74 92 1 332 480	74	5	25
62 11 1 334 125	62	2	24	62 14 1 334 327	62	2	10	74 92 1 332 484	74	2	1
62 11 1 334 125	62	3	24	62 14 1 334 327	62	3	10	74 92 1 332 635	74	5	39
62 11 1 334 126	62	3	25	62 14 1 334 328	62	2	11	74 92 1 332 638	74	5	26
62 11 1 334 129	62	2	28	62 14 1 334 328	62	3	11	74 92 1 332 639	74	5	10
62 11 1 334 129	62	3	28	62 14 1 334 328	62	3	11	74 92 1 332 641	74	5	1
62 11 1 334 130	62	2	29	62 14 8 648 136	62	1	2	74 92 1 332 642	74	5	2
62 11 1 334 130	62	3	29	62 14 8 680 131	62	1	33	74 92 1 332 647	74	5	27
62 11 1 334 216	62	2	27	62 16 1 334 203	62	2	33	74 92 1 332 668	74	5	41

Teilenummern-Index  
Part Number index  
Index des numéros de pièces  
Reservdelsnummer-Index  
Indice dei numeri dei pezzi di ricambio

**00**  
**29**  
4/86

D 150 / D 190 / D 530 / D 636

Teile-Nummer	HG	S	Nr.								
74 92 1 332 673	74	5	24								
74 92 1 332 676	74	5	29								
74 92 1 332 677	74	5	9								
74 92 1 763 231	74	5	44								
74 92 1 763 277	74	3	19								
74 92 1 763 283	74	3	20								
74 92 1 763 624	74	3	2								
74 92 1 763 660	74	4	11								
74 92 1 763 787	74	4	7								
74 92 1 763 788	74	4	12								
74 92 1 763 789	74	4	9								
74 92 1 763 792	74	5	19								
74 92 1 763 793	74	5	18								
74 92 1 763 794	74	4	13								
74 92 1 763 795	74	4	1								
74 92 1 763 796	74	5	42								
74 92 1 763 797	74	5	43								
74 92 1 763 841	74	3	13								
74 92 1 763 880	74	4	12								
74 92 1 763 927	74	3	9								
74 92 1 763 928	74	3	8								
74 92 1 763 931	74	4	5								



G-Motor  
G-Engine  
G-Moteur  
G-Motor  
G-Motore

BMW D 150 / D 190 / D 530 / D 636

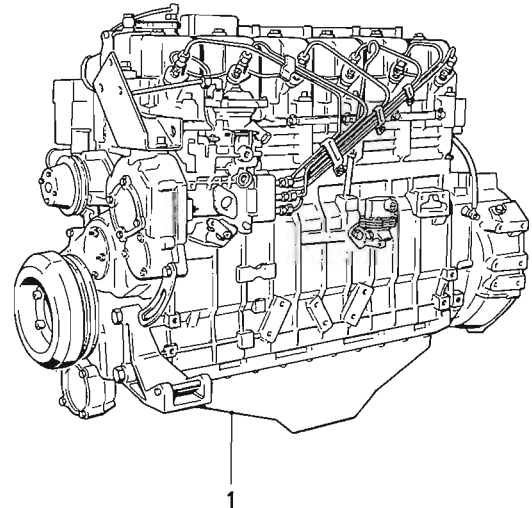
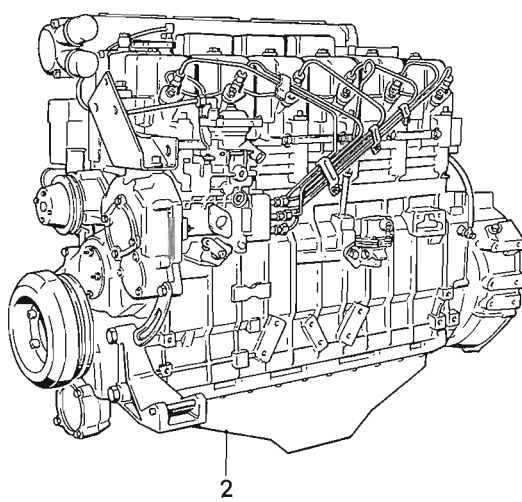

**11**  
**1**

D 150/190/530/636  
4/86

		4/86						D 150	D 190	D 530	D 636	
Nr.	Teile-Nummer	Symbol	Benennung	D 150	D 190	D 530	D 636	Bemerkung				
1	a 1100 1331 185		G-Motor / G-Engine / G-Moteur / G-Motor / G-motore	1								
2	a 1100 1761 644		dito		1							
	a 1100 1761 350		dito				1					
	a 1100 1763 682		dito									

a) Grundmotor o. Elektrik, Anlasser, Lichtmaschine u. Motorpratze  
Basic engine unit without electrical equipment, starter, generator and engine claw  
Moteur de base sans équipements électriques, démarreur, dynamo et griffe de moteur  
Grundmotor utan El-utrustning, Startare, Generator och Motorklo  
Motore base senza equipaggiamento elettrico, motorino d'avviamento, dinamo e giunto a denti del motore

V12 Engineering  
www.bmwmarine.com

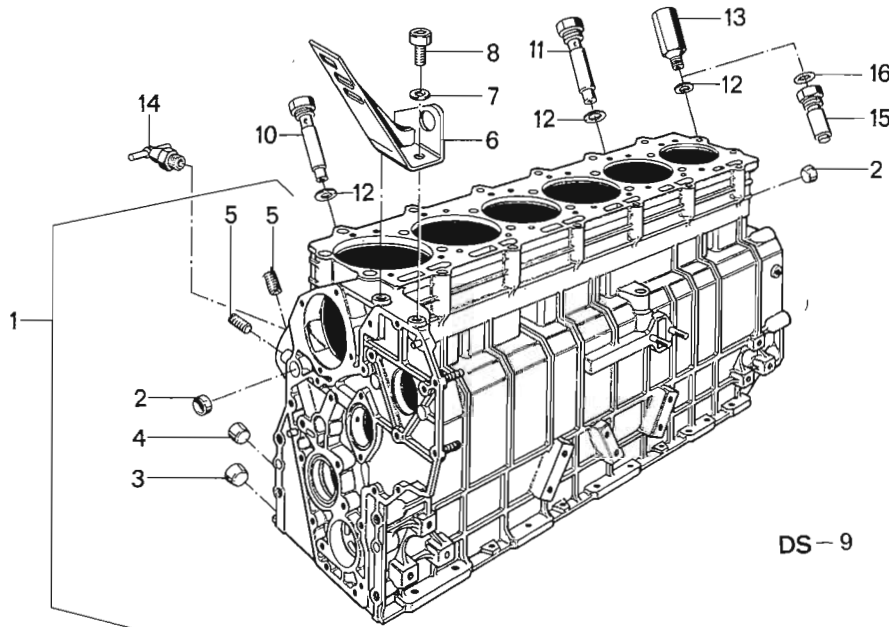

DS - 9

11  
2

D 150/190/530/636  
4/86

11 2		4/86									
Nr.	Teile-Nummer	Symbol	Benennung	D 150	D 190	D 530	D 636	Bemerkung			
1	a 11 111 1331 600		Kurbelgehäuse/ Crankcase / Carter-moteur / Vevhus / Carter del manovellismo	1	1	1					
	11 111 1763 685		dito			1					
2	11 111 1331 602		Ø 18 Verschlussdeckel / Cover / Bouchon / Lock / Coperchio di chiusura	2	2	2	2				
3	07 119 937 241		Ø 16	2	2	2	2				
4	11 111 1331 603		Ø 15,2	1							
5	11 111 1331 604		VSL-SHR M 6 × 1	5	5	5	5				
6	11 111 1331 139		Stützwinkel vorne / Support anale front / Support moteur avant / Vinkelstöd fram / Angolo di supporto anteriore, avanti	1	1						
	11 111 1761 848		dito			1	1				
7	07 119 931 076		A 10,5 Scheibe / Washer / Rondelle / Bricka / Rondella	2	2	2	2				
8	07 119 919 933		ZYL SHR M 10 × 20	2	2	2	2				
9	b 11 111 1333 859	DS	kpl. Motor / Engine / Moteur / Motor / Motore	1	1						
	b 11 111 1763 371	DS	dito				1				
	b 11 111 1763 683	DS	dito								
10	11 211 1331 650		Fixierschraube / Lecating screw / Vis de positionnement / Fixerskruv / Vite di posizionamento	4	4	3	4				
11	11 211 1331 651		dito	1	1						
12	07 119 963 201		A 14 DT RG	6	6	5	6				
13	12 611 333 976		Distanzstück / Spacer / Entretoise / Distanzstykke / Pezzo distanziatore	1	1						
	11 211 1763 387		dito			1	1				
14	11 111 1331 684		Ablaßhahn / Drain cock / Robinet de vidange / Utloppskran Rubinetto di scarico	1	1	1	1				
15	11 211 1763 388		Anschlußstutzen / Connecting piece / Pièce de raccordement / Kopplingsstykke / Raccordo			1	1				
16	07 119 963 072		A 10 DT RG			1	1				

a) inkl. Hauptlager u. Nockenwellenbüchsen / Including main bearing and camshaft bushes / Y compris le palier principal et les chemises de l'arbre à cames /  
Inklusiv huvudlager och kamaxelbusningar / Incluso il supporto di banco dell'albero motore e boccola dell'albero a camme  
b) ohne Zyl. Kopfdichtung u. Ausgleichscheiben / Without cylinder head gasket and compensating washers / Sans joint de culasse de cylindre et rondelles  
de compensation / utan cylinderhuvudets tätning och mellanlägg / senza guarnizione della testa cilindri e ranelle di spessore

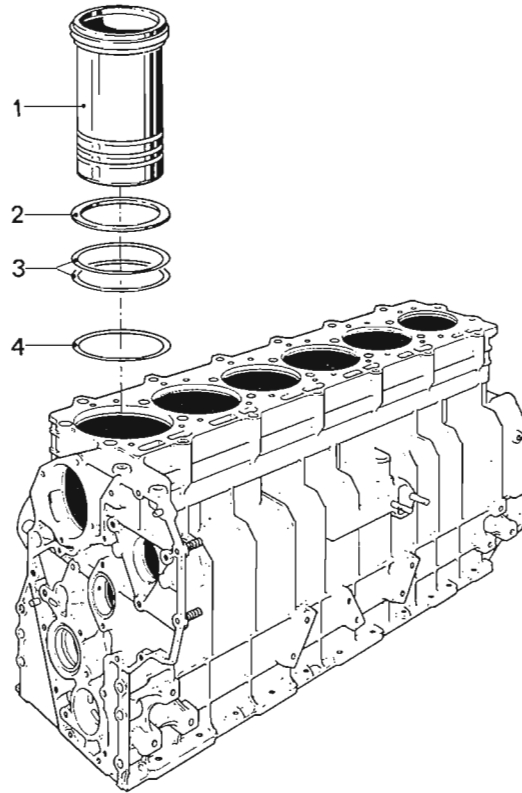

**11**  
**3**

D 150/190/530/636  
4/86

11 3		4/86										
Nr.	Teile-Nummer	Symbol	Benennung	D 150	D 190	D 530	D 636					Bemerkung
1	11 111 1331 605 11 111 1331 626		Zylinder-Laufbüchsen / Cylinder lines / Chemises de cylindres / Cylinderfoder / Canne del cilindro A 92,0 ÷ 92,01 B 92,01 ÷ 92,02	6 6	6 6	5 5	6 6					
2	11 111 1331 607 11 111 1331 608 11 111 1763 362		Ausgleichsscheibe / Compensation shim / Disque de compensation / Mellanlägg / Rondella di spessore 0,15 0,20 0,23	X X X	X X X	X X X	X X X					
3	a) 11 111 1331 610		Ø 94,92 O-Ring / O-ring / Joint torique / O-ring / Anello-O	12	12	10	12					
4	b) 11 111 1331 611		Ø 94,92	6	6	5	6					

V12 Engineering  
 Box 50, Ontario, Canada POX 1C0  
[www.bmwmarine.net](http://www.bmwmarine.net)

a) rot / red / rouge / röd / rosso  
 b) schwarz / black / noir / svart / nero

V12 Engineering  
[www.bmwmarine.com](http://www.bmwmarine.com)



Zylinderkopf  
Cylinder head  
Culasse de cylindre  
Cylindertopp  
Testata

BMW D 150 / D 190 / D 530 / D 636

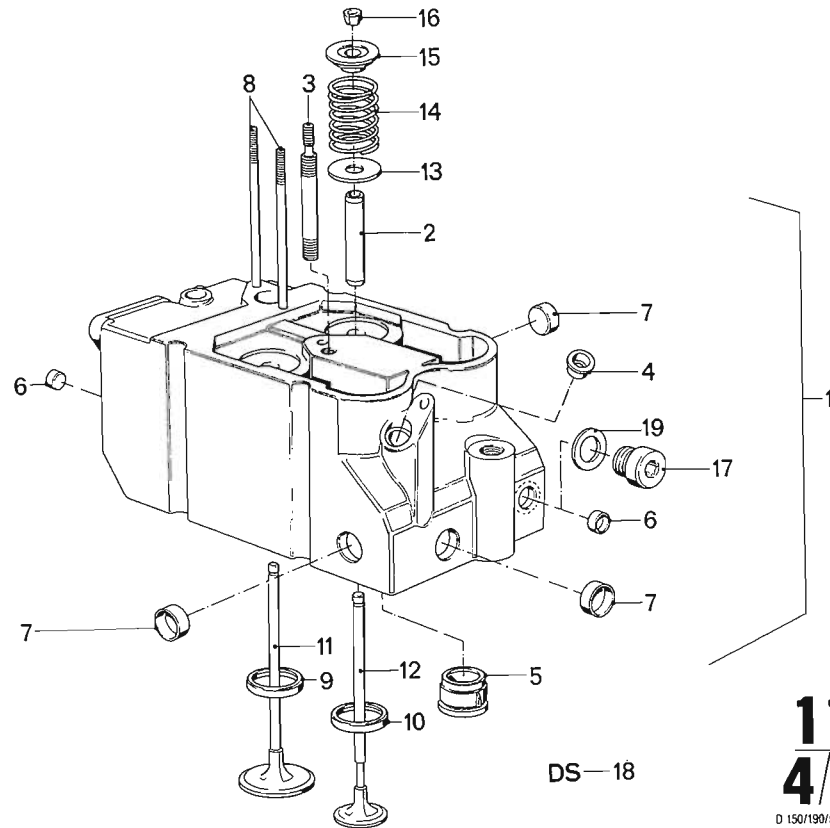

DS—18

**11**  
**4/1**

D 150/190/530/636  
4/86

11 4/1		4/86									
Nr.	Teile-Nummer	Symbol	Benennung	D 150	D 190	D 530	D 636	Bemerkung			
1	a 11 34 1 331 199		kpl. Zylinderkopf / Cylinder head / Culasse de cylindre / Cylindertopp / Testata	6	6						
	a 11 34 1 763 395		dito			5	6				
2	11 12 1 763 692		0,10 Ventilführung / Valve guide / Guide de soupape / Ventilstyrning / Guida-valvola	12	12	10	12				
3	11 12 1 331 662		STISHR	6	6	5	6				
4	13 53 1 331 213		Zentrierbuchse / Centering bush / Douille de centrage / Centreringshylsa / Boccola di centraggio	6	6	5	6				
5	11 12 1 331 663		Vorkammer / Prechamber / Chambre de précombustion / Förcammare / Camera di precombustione	6	6						
	11 12 1 763 564		dito			5	6				
6	11 12 1 331 664		Ø 10,2 Verschlussdeckel / Cover / Bouchon / Lock / Coperchio di chiusura	12	12	10	12				
7	11 12 1 331 665		Ø 20,2	18	18	10	18				
8	11 12 1 331 666		STISHRM 6 x 78	12	12	10	12				
9	11 12 1 331 660		normal – Ventil Sitzring-Einlaß / Valve seat ring – inlet / Admission – siège de soupape rapporté / Normalventilsättesring / Anello sede valvola-aspirazione	6	6						
	11 12 1 763 562		dito			5	6				
	11 12 1 331 682		dito + 0,30			5	6				
10	11 12 1 331 661		normal – Ventil Sitzring-Auslaß / Valve seat ring – outlet / Sortie – siège de soupape rapporté / Ventil sättesring – utgång / Anello sede valvola-scarico	6	6						
	11 12 1 763 563		dito			5	6				
	11 12 1 331 683		dito + 0,30			5	6				
11	11 34 1 331 751		Ventilkegel-Einlaß / Inlet valve cone / Tête de soupape d'admission / Ventilkögla intag / Entrata cono valvola	6	6	5	6				
12	11 34 1 331 750		Ventilkegel-Auslaß / Outlet valve cone / Tête de soupape d'échappement / Ventilkögla utlopp / Uscita cono valvola	6	6	5	6				

a) mit Ventile / with valve / avec soupape / med ventil / con valvola

b) ohne Zylinderkopfdichtung / without cylinder head gasket / sans joint de culasse de cylindre / utan cylinderhuvudets tätning / senza guarnizione della testa cilindri

Zylinderkopf  
Cylinder head  
Culasse de cylindre  
Cylindertopp  
Testata

BMW D 150 / D 190 / D 530 / D 636

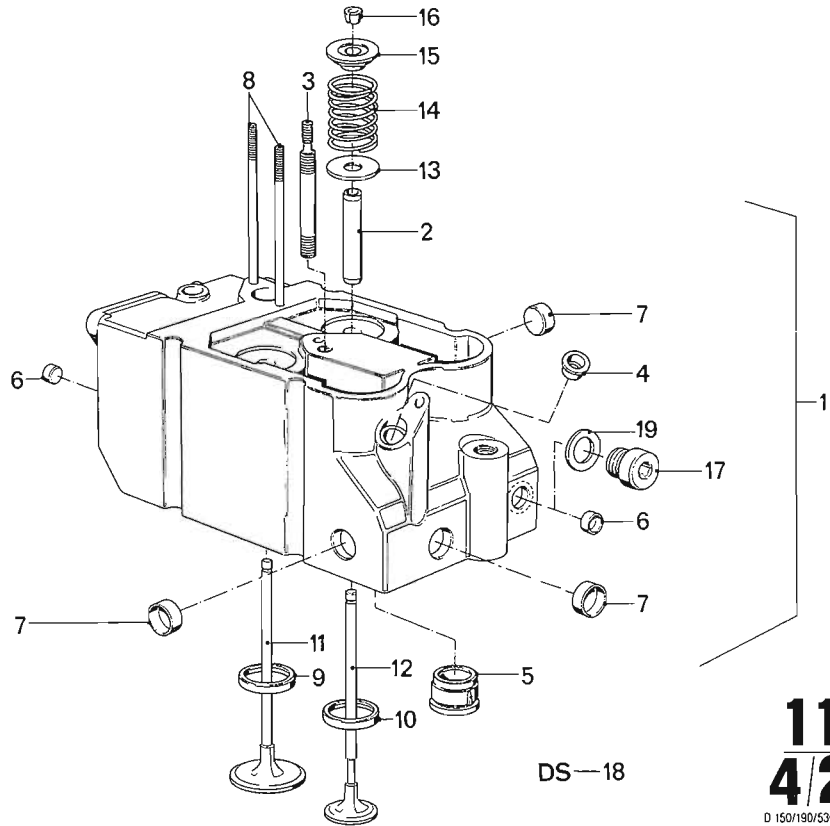

DS—18

**11**  
**4/2**  
D 150/190/530/636  
4/86

11 4/2		4/86					D 150	D 190	D 530	D 636		
Nr.	Teile-Nummer	Symbol	Benennung							Bemerkung		
13	11 34 1 331 752		Unterlegscheibe / Washer / Rondelle / Underläggsbricka / Disco d'appoggio	12	12	10	12					
14	11 34 1 331 753		Ventilfeder / Valve spring / Ressort de soupape / Ventilsfjäder / Molla della valvola	12	12	10	12					
15	11 34 1 331 754		Federteller / Spring plate / Disque de ressort / Fjäderbricka / Scodellino	12	12	10	12					
16	11 34 1 331 755		Ventilkonus / Valve cone / Cône de soupape / Ventilkona / Cono valvola	24	24	20	24					
17	11 12 1 763 377		M 20 x 1,5 VSL SHR			5	6					
18	b 11 12 1 333 860	DS	Zylinderkopf / Cylinder head / Culasse de cylindre / Cylindertopp / Testata	1	1							
	b 11 12 1 763 381	DS	dito				1					
	b 11 12 1 763 764	DS	dito				1					
19	07 11 9 963 342		A 20 DTRG			5	6					

**V12 Engineering**  
Box 50, Ontario, Canada P0X 1C0  
[www.bmwmarine.net](http://www.bmwmarine.net)

a) mit Ventile / with valve / avec soupape / med ventil / con valvola  
b) ohne Zylinderkopfdichtung / without cylinder head gasket / sans joint de culasse de cylindre / utan Cylindrhuvudets tätning / senza guarnizione della testa cilindri

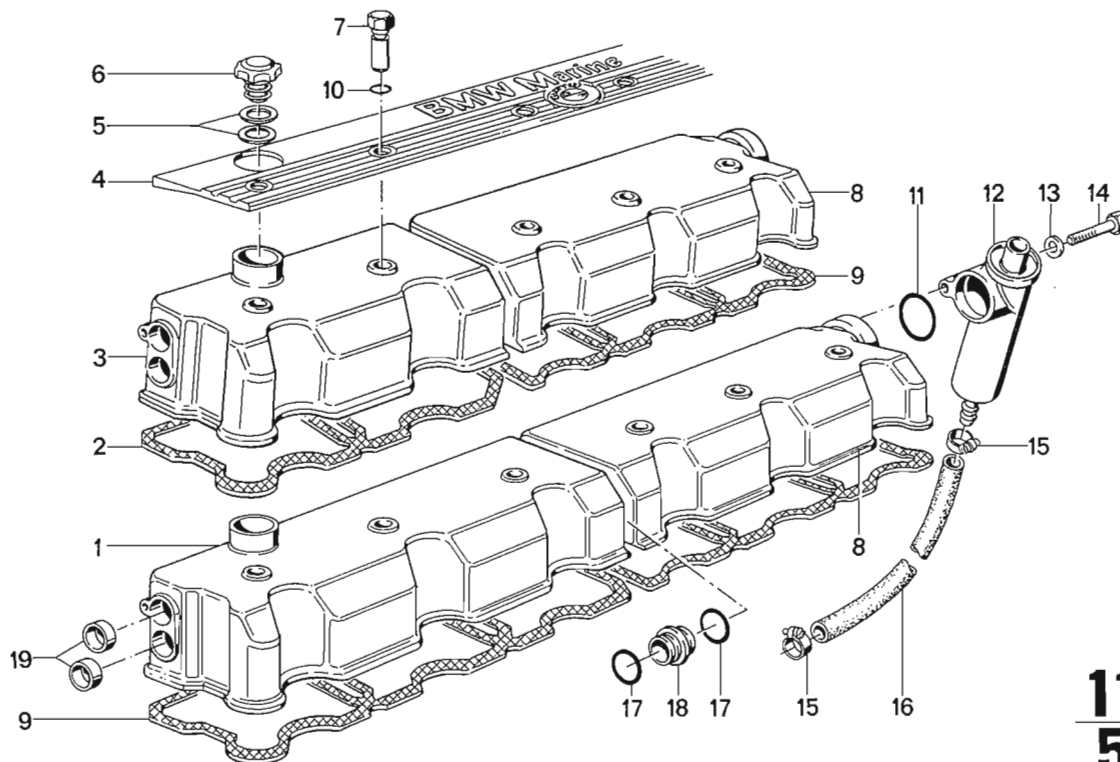

**11**  
**5**

D 530/636  
4/85

11 5		4/86								
Nr.	Teile-Nummer	Symbol	Benennung	D 150	D 190	D 530	D 636	Bemerkung		
1	11 12 1763 766		Zylinderkopfhaube – vorne / Cylinder head cover – front / Couvre-culasse – avant / Ventilkåpa – framför / Coperchio testa cilindro – anteriore				1			
2	11 12 1763 768		Dichtung / Seal / Garniture / Packning / Guarnizione			1				
3	11 12 1763 766		Zylinderkopfhaube – vorne / Cylinder head cover – front / Couvre-culasse – avant / Ventilkåpa – framför / Coperchio testa cilindro – anteriore			1				
4	11 12 1763 772		Abdeckung / Cover / Couvercle / Lock / Copertura			1				
	11 12 1763 791		dito			1				
5	11 12 1331 690		O-Ring / O-ring / Joint torique / O-ring / Anello-O	2	2	2	2			
6	11 12 1331 689		Verschlußdeckel / Blanking cover / Couvercle d'obturation / Täcklock / Coperchio di chiusura	1	1	1	1			
7	11 12 1763 773		Tauchmutter / Submersible nut / Ecrou plongeur / Doppmutter / Dado di immersione			5	6			
8	11 12 1763 771		Zylinderkopfhaube – hinten / Cylinder head cover – rear / Couvre-culasse – arrière / Ventilkåpa – baktill / Coperchio testa cilindro – posteriore			1	1			
9	11 12 1763 765		Dichtung / Seal / Garniture / Packning / Guarnizione			1				
10	11 12 1763 779		O-Ring / O-ring / Joint torique / O-ring / Anello-O			5	6			
11	11 15 1285 797		O-Ring / O-ring / Joint torique / O-ring / Anello-O			1	1			
12	11 15 1285 638		Ölabscheider / Oil separator / Separateur d'huile / Olje-avskiljare / Separatore olio			1	1			
13	07 11 9931 067		A 8,4 Scheibe / Washer / Rondelle / Bricka / Rondella			1	1			
14	07 11 9912 529		6 KT SHR M 8 x 60			1	1			
15	07 12 9952 104		10-16 Schelle / Clamp / Collier / Klämna / Fascetta			2	2			
16	11 15 1763 774		Ölablaßschlauch / Oil drain tube / Tuyau de virdange d'huile / Oljeavtappings slang / Tubo flessibile di scarico olio			1				
17	11 12 1763 770		O-Ring / O-ring / Joint torique / O-ring / Anello-O			4	4			
18	11 12 1763 769		Verbindungsstück / Connecting piece/element / Raccord / Förbindelsestycke/del / Pezzo/elemento di collegamento			2	2			
19	11 12 1763 972		VSL-Deckel / VSL Cover / VSL Couvercle / VSL Lock / VSL Coperchio			2	2			

Zylinderkopfdeckel  
Cylinder head cover  
Couvre-culasse  
Ventilkåpa  
Coperchio testa cilindro

BMW D 150 / D 190 / D 530 / D 636

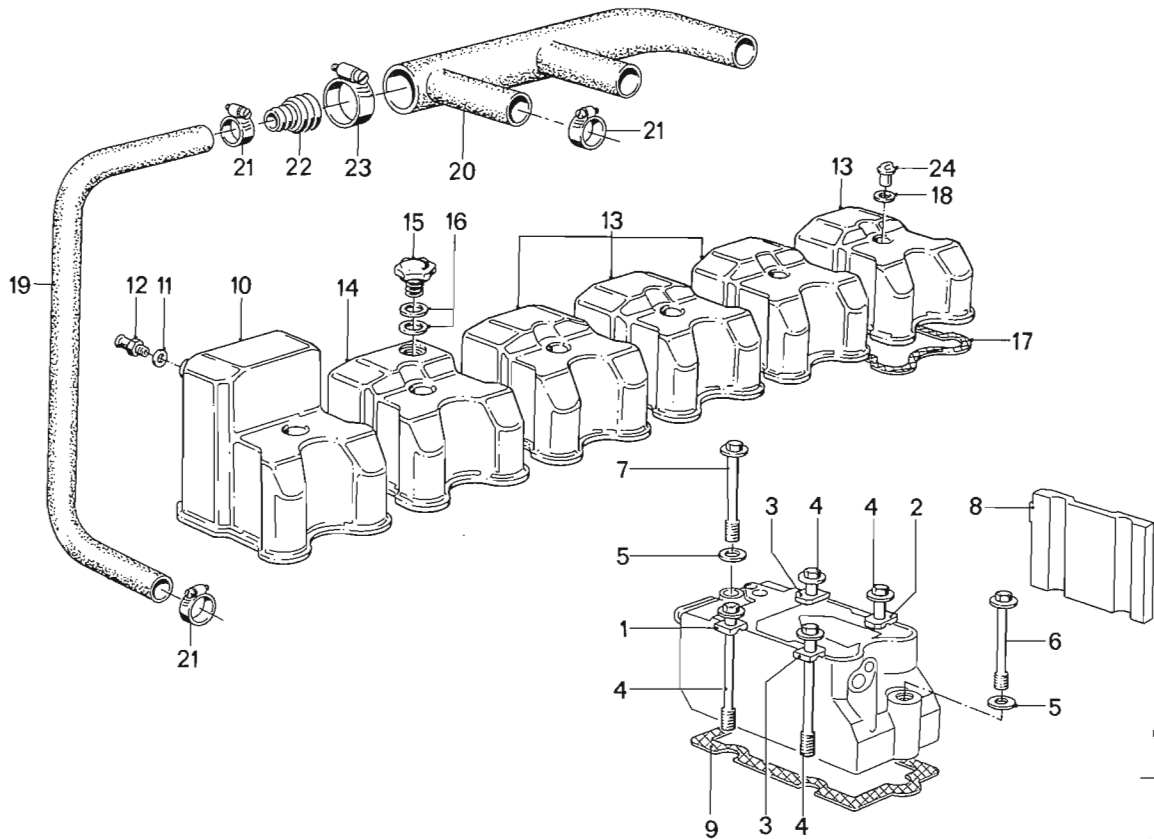

**11**  
**6**

D 150/190  
4/86

<b>11</b> <b>6</b>		4/86					D 150	D 190	D 530	D 636	Bemerkung
Nr.	Teile-Nummer	Symbol	Benennung								
1	11 12 1 331 671		Klemmbrücke / Terminal bridge / Etrier de serrage / Klämbrygga / Morsettiera				7	7	6	7	
2	11 12 1 331 673		dito				2	2	2	2	
3	11 12 1 331 674		dito				5	5	4	5	
4	11 12 1 331 675		Zylinderkopfschraube / Cylinder head bolt / Vis de culasse / Cylinderlocksskruv / Prigioniero di fissaggio testa cilindri				14	14	12	14	
5	11 12 1 331 676		Scheibe / Washer / Rondelle / Bricka / Rondella				12	12	10	12	
6	11 12 1 331 677		Zylinderkopfschraube / Cylinder head bolt / Vis de culasse / Cylinderlocksskruv / Prigioniero di fissaggio testa cilindri				6	6	5	6	
7	11 12 1 331 678		dito				6	6	5	6	
8	11 12 1 331 670		Distanzstück / Spacer / Pièce d'écartement / Distanzstykke / Pezzo distanziatore				2	2	2	2	
9	11 12 1 331 668		1,42 Dichtung / Seal / Garniture / Packning / Guarnizione				6	6	5	6	
	11 12 1 763 214		1,52 dito				6	6	5	6	
	11 12 1 331 669		1,62 dito				6	6	5	6	
10	11 12 1 331 679		Deckel / Cover / Couvercle / Lock / Coperchio				1	2			
11	07 11 9 963 308		18 x 22 DT RG				1	3			
12	11 12 1 331 680		Stutzen / Connection / Tubulure / Stuts / Bocchettone				1	3			
13	11 12 1 331 687		Deckel / Cover / Couvercle / Lock / Coperchio				4	4			
14	11 12 1 331 688		dito				1	1			
15	11 12 1 331 689		VSL-Deckel / VSL-Cover / VSL-Couvercle / VSL-Lock / VSL-Coperchio				1	1	1	1	
16	11 12 1 331 690		O-Ring / O-ring / Joint torique / O-ring / Anello-O				2	2	2	2	
17	11 12 1 331 691		Dichtung / Seal / Garniture / Packning / Guarnizione				6	6	6	6	
18	11 12 1 331 692		O-Ring / O-ring / Joint torique / O-ring / Anello-O				6	6	6	6	
19	13 72 1 763 212		Schlauch / Hose / Tuyau / Slang / Tubo flessibile				1				
20	13 72 1 761 759		dito				1				
21	11 53 1 326 638		16-25 Schelle / Clamp / Collier / Klämma / Fascetta						5		
22	13 72 1 761 729		Reduzierstück / Reduzer / Réduction / Reduktion / Elemento di riduzione						1		
23	11 53 1 761 179		20-32 Schelle / Clamp / Collier / Klämma / Fascetta						1		
24	11 12 1 331 693		MU				6	6			

V12 Engineering  
Box 50, Ontario, Canada POX 1C0  
www.bmwmarine.net

V12 Engineering  
www.bmwmarine.com

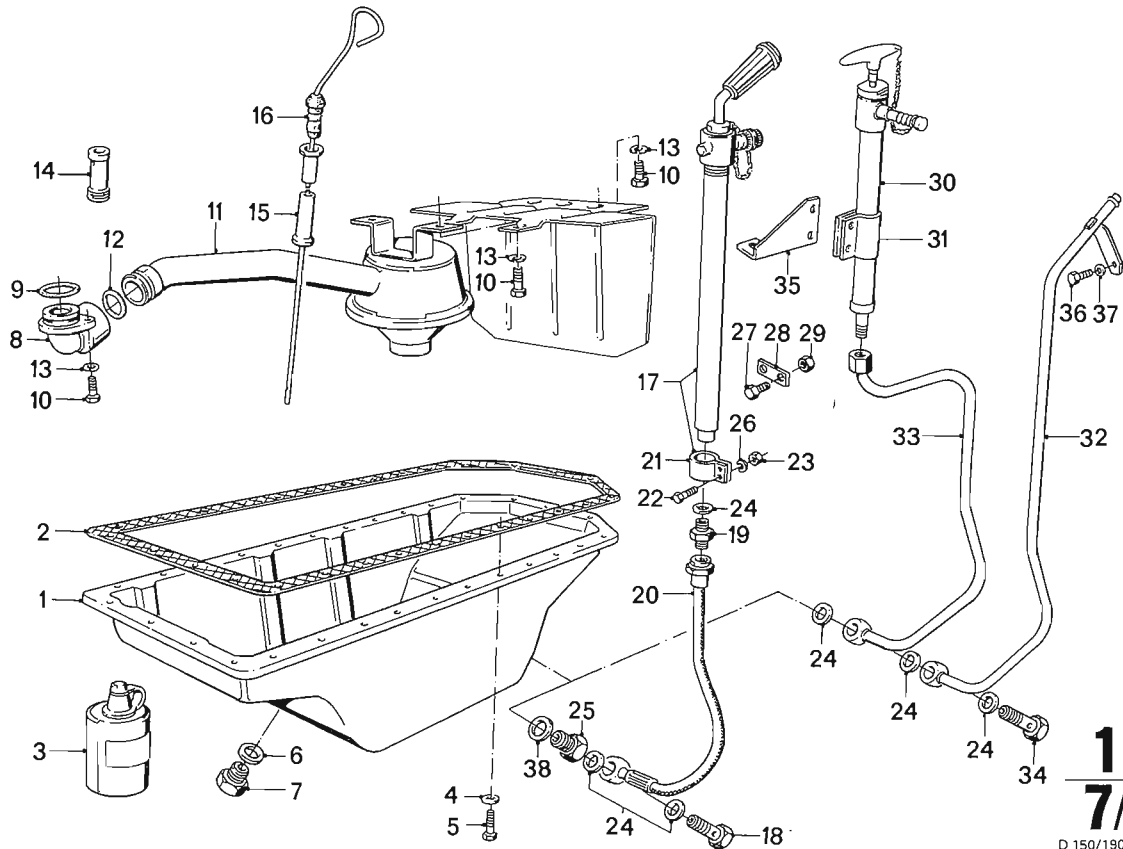

**11**  
**7/1**

D 150/190/530/636  
4/86

11 7/1		4/86									
Nr.	Teile-Nummer	Symbol	Benennung	D 150	D 190	D 530	D 636	Bemerkung			
1	11 13 1331 612		Ölwanne / Oil pan / Carter d'huile / Öljeträg / Coppa dell'olio	1	1						
	11 13 1763 597		dito - Blech / Plate / Tôle / Piât / Lamiera			1					
	11 13 1763 762		dito			1					
2	11 13 1331 613		Dichtung / Seal / Garniture / Packning / Guarnizione	1	1	1					
	11 13 1763 694		dito			1					
3	07 58 9056 979		Dichtmasse / Sealing compound / Matière cutante / Tätningsmaterial / Massa di tenuta	1	1						
4	07 11 9931 044		6,4 Scheibe / Washer / Rondelle / Bricka / Rondella	29	29	24					
5	07 11 9913 483		6KT SHR M 6 x 25	29	29						
	07 11 9913 466		6KT SHR M 6 x 16				29				
	07 11 9913 410		6KT SHR M 6 x 14			24					
6	11 43 1763 384		A 22 DTRG	2	2	2					
7	11 13 1333 862		VSL SHR M 22 x 1,5	1	1						
8	11 41 1333 414		Krümmer / Elbow / Coude / Krök / Gomito	1	1	1	1				
9	11 41 1333 415		O-Ring / O-ring / Joint torique / O-ring / Anello-O	1	1	1	1				
10	07 11 9913 450		6KT SHR M 6 x 14	3	3	3					
	07 11 9913 442		6KT SHR M 6 x 12			4	3				
11	11 41 1333 413		Saugrohr / Suction tube / Tube d'aspiration / Insuigningsrör / Tubo di aspirazione	1	1						
	11 41 1763 601		dito				1				
	11 41 1763 697		dito			1					
12	11 41 1333 416		O-Ring / O-ring / Joint de torique / O-ring / Anello-O	1	1	2	2				
13	07 11 9932 071		B 6 Federscheibe / Spring washer / Rondelle élastique / Fjäderbricka / Rosetta elastica	4	4	1	4				
14	11 41 1333 417		kpl. Überdruckventil / Relief valve / Soupape de sureté / Säkerhetsventil / Valvola limitatrice d. pressione	1	1	1	1				
15	11 43 1333 425		Rohr / Tube / Tuyau / Rör / Tubo	1	1	1	1				
16	11 43 1333 426		Ölmeßstab / Dipstick / Jauge d'huile / Öljetätssticka / Asta controllo livello olio	1	1						
	11 43 1763 600		dito				1				
	11 43 1763 699		dito			1					
17	11 43 1333 428		kpl. Ölabsaugpumpe / Oil suction pump / Pompe d'aspiration d'huile / Öljetätsugningspumpe / Pompa di aspirazione dell'olio	1	1						
18	32 41 1117 181		M 14 x 1,5 Hohlsschraube / Banjo bolt / Vis creuse / Hålskräv / Vite cava	1	1		1				
19	07 11 9964 530		Stutzen / Connection / Tubulure / Stuts / Bocchettone	1	1						

www.bmw-marine.com

V12 Engineering

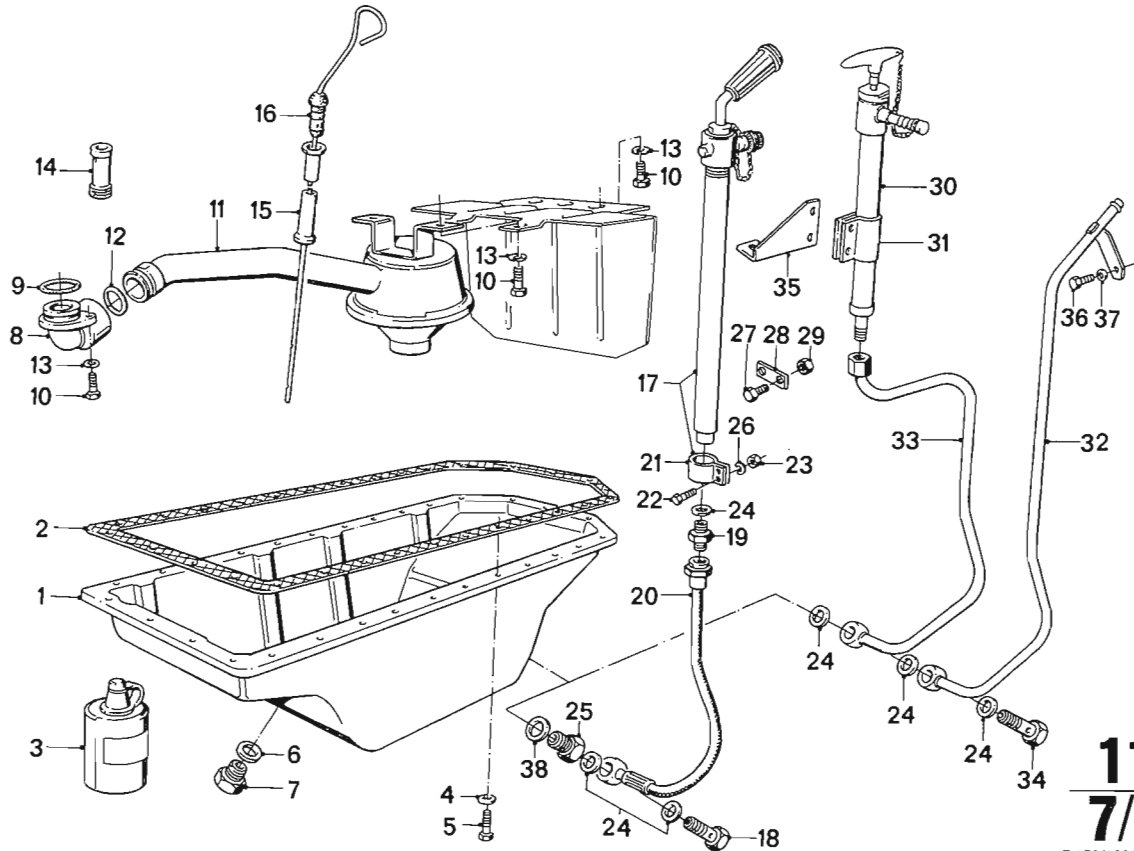

**11**  
**7/2**

D 150/190/530/636  
4/86

11 7/2		4/86									
Nr.	Teile-Nummer	Symbol	Benennung	D 150	D 190	D 530	D 636	Bemerkung			
20	11 43 1761 663		Ölleitung / Oil pipe / Conduite d'huile / Oljeledning / Tubatura olio	1	1						
21	11 43 1333 431		Schelle / Coil clip / Collier / Klammer / Fascetta	1	1						
22	07 11 9913 477		6 KT SHR M 6 x 20	2	2		2				
23	07 11 9922 058		6 KT MU M 6	2	2		2				
24	07 11 9963 201		DTRG	2	2	4	3				
25	11 43 1333 433		M 14 x 1,5 Reduzierstück / Reduzer / Réduction / Reduktion / Elemento di riduzione	1	1		1				
	11 13 1333 862		dito				1				
26	07 11 9932 072		B 6 Federscheibe / Spring washer / Rondelle élastique / Fjäderbricka / Rosetta elastica	2	2	2	2				
27	07 11 9913 843		6 KT SHR M 10 x 35	1	1						
28	11 43 1331 175		Halter / Support / Support / Fäste / Sostegno	1	1						
29	07 11 9922 113		6 KT MU M 10	1	1						
30	11 43 1761 921		kpl. Ölabsaugpumpe / Oil suction pump / Pompe d'aspiration d'huile / Öljeutsugningspump / Pompa di aspirazione dell'olio				1				
	11 43 1763 776		dito				1				
31	11 43 1761 922		Schelle / Clamp / Collier / Klämma / Fascetta				1				
32	11 43 1763 594		Ölrücklaufleitung / Oil return pipe / Canalisation de retour / Atergångsledning / Tubo di circolazione olio				1				
	11 43 1763 840		dito				1				
33	11 43 1763 595		Ölabsaugleitung / Oil drain line / Conduite d'aspiration d'huile / Öljeutsugningsledning / Conduittura di aspirazione dell'olio				1				
34	11 43 1763 596		M 14 x 1,5 Doppelhohlschraube / Double banjo bolt / Vis creuse double / Dubbelhålskräv / Doppia vite cava				1				
35	11 43 1763 527		Winkel / Angle / Corniere / Vinkel / Sostegno				1				
	11 43 1763 923		dito				1				
36	07 12 9922 410		4 KT SHR				1				
37	07 11 9931 036		A 5,3 Scheibe / Washer / Rondelle / Bricka / Rondella				1				
38	11 43 1333 432		30 x 22 DTRG				1				

Räderkastendeckel  
 Gear housing cover  
 Chape de la borte  
 Transmissions-Käpa  
 Coperchio scatola della distribuzione

BMW D 150 / D 190 / D 530 / D 636

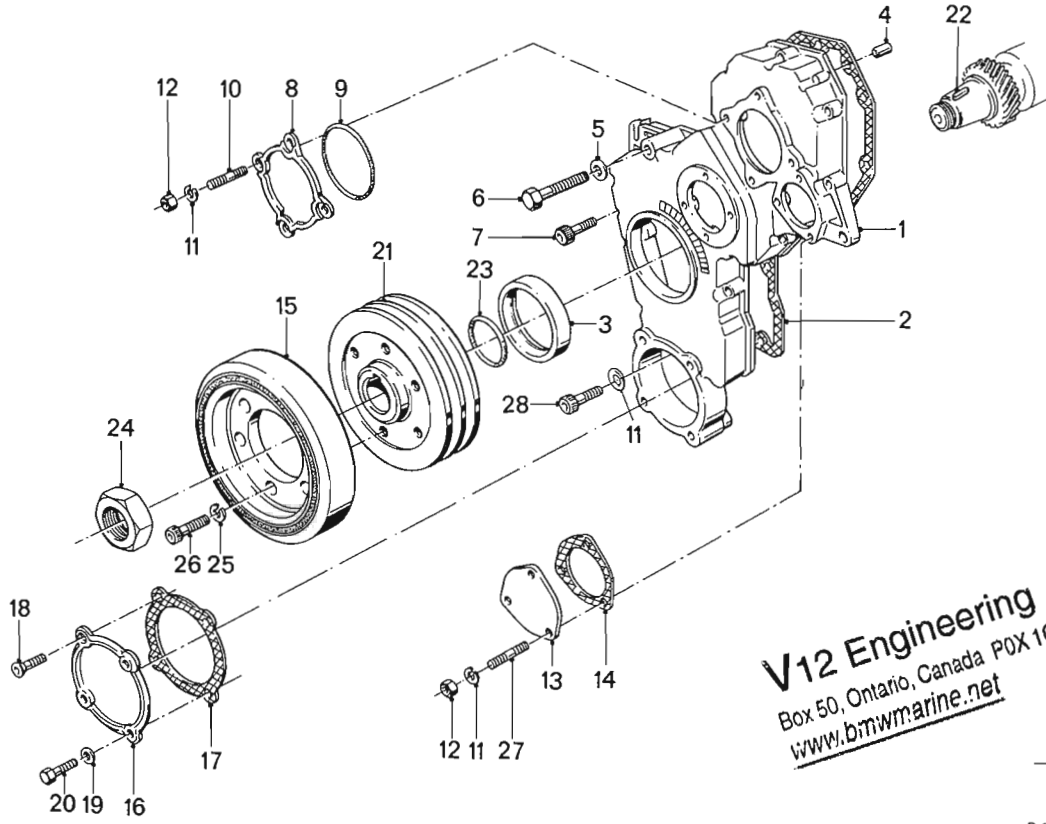

V12 Engineering  
 Box 50, Ontario, Canada POX 1C0  
 www.bmwmarine.net

11  
 8/1

D 150/190/530/636  
 4/86

11 8/1		4/86									
Nr.	Teile-Nummer	Symbol	Benennung	D 150	D 190	D 530	D 636	Bemerkung			
1	11 14 1 331 615		Räderkastendeckel / Gear housing cover / Chape de la borte / Transmissions-Käpa / Coperchio scatola della distribuzione	1	1	1	1				
2	11 14 1 331 616		Dichtung / Seal / Garniture / Packning / Guarnizione	1	1	1	1				
3	11 14 1 331 617		Wellendichtring / Shaft seal / Bague d'étanchéité radiale / Tätningsring axel / Anello di tenuta	1	1	1	1				
4	11 14 1 331 212		6 x 18 Paßstift / Pin / Goupille d'ajust / Staallstift / Spina d. registr.	2	2	2	2				
5	07 11 9931 067		A 8,4 Scheibe / Washer / Rondelle / Bricka / Rondella	1	1	1	1				
6	07 11 9913 689		6 KT SHR M 8 x 60	1	1	1	1				
7	07 11 9919 926		ZYL SHR M 6 x 25	13	13	13	13				
8	11 14 1 331 618		Deckel / Cover / Couvercle / Lock / Coperchio	1	1	1	1				
9	11 14 1 331 619		O-Ring / O-ring / Joint torique / O-ring / Anello-O	1	1	1	1				
10	11 14 1 331 210		STISHRM 6 x 16	4	4	4	4				
11	07 11 9932 072		B 6 Federscheibe / Spring washer / Rondelle élastique / Fjäderbricka / Rosetta elastica	7	7	7	7				
12	07 11 9922 058		6 KTMUM 6	7	7	7	7				
13	11 14 1 331 620		Deckel / Cover / Couvercle / Lock / Coperchio	1	1	1	1				
14	11 14 1 331 621		Dichtung / Seal / Garniture / Packning / Guarnizione	1	1	1	1				
15	11 23 1 331 708		Schwingungsdämpfer / Vibration damper / Amortisseur de vibration / Vibrationsdämpare / Ammortizzatore	1	1	1	1				
16	11 14 1 331 622		Deckel / Cover / Couvercle / Lock / Coperchio	1	1	1	1				
17	11 14 1 331 623		Dichtung / Seal / Garniture / Packning / Guarnizione	1	1	1	1				
18	11 14 1 331 211		SK SHR	1	1	2	1				
19	07 11 9932 095		B 8 Federschraube / Spring washer / Rondelle élastique / Fjäderbricka / Rosetta elastica	3	3	2	3				
20	07 11 9913 644		6 KT SHR M 8 x 20	3	3	2	3				
21	11 23 1 331 704		Riemenscheibe / Belt pulley / Poulie de courroie / Remskiva / Pullegia	1	1						
	11 23 1 763 565		dito			1	1				
22	11 23 1 331 705		Paßfeder / Feather key / Ressort d'ajustage / Passkil / Chiavetta	1	1	1	1				
23	11 23 1 331 706		O-Ring / O-ring / Joint torique / O-ring / Anello-O	1	1	1	1				
24	11 23 1 331 707		6 KT MU	1	1	1	1				

www.v12engineering.com

Räderkastendeckel  
 Gear housing cover  
 Chape de la borte  
 Transmissions-Kåpa  
 Coperchio scatola della distribuzione

BMW D 150 / D 190 / D 530 / D 636

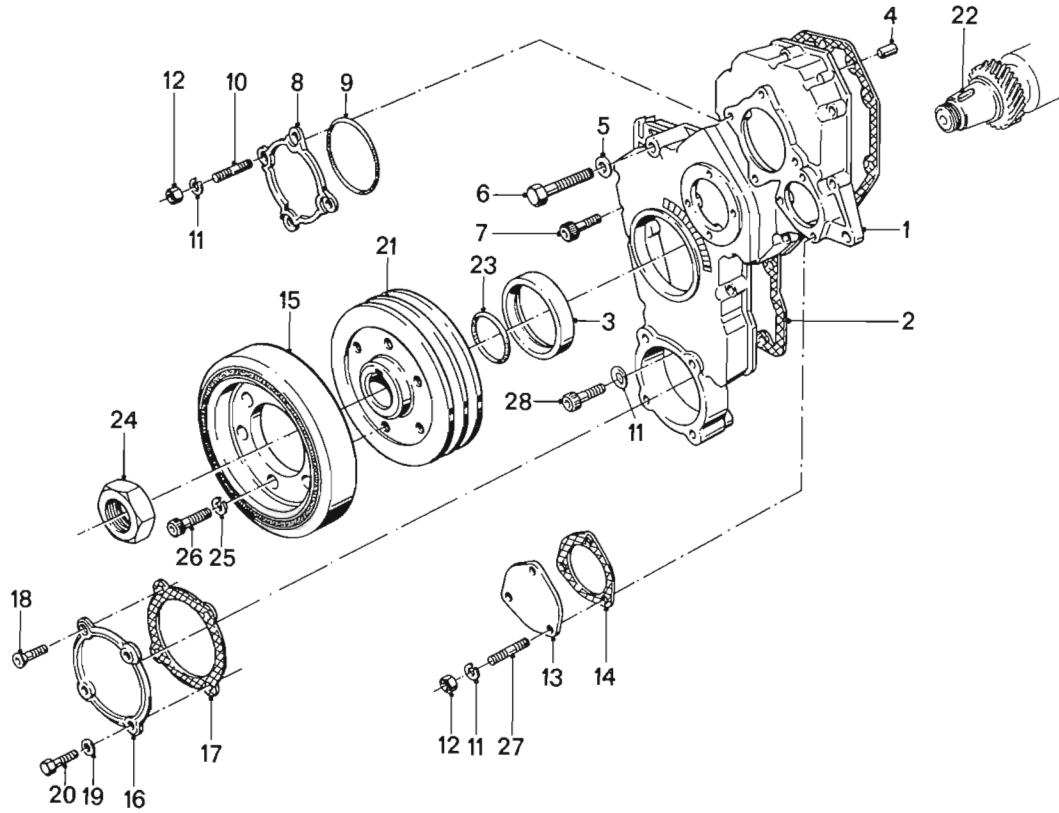

**11**  
**8/2**

D 150/190/530/636  
4/86

11 8/2												
4/86												
Nr.	Teile-Nummer	Symbol	Benennung				D 150	D 190	D 530	D 636	Bemerkung	
25	07 11 9933 251		10 Federring / Spring lock washer / Rondelle élastique / Fjäderbricka / Anello elastico				6	6	6	6		
26	07 11 9919 682		ZYL SHR M 10 x 25				6	6	6	6		
27	11 14 1761 801		STI SHR M 6 x 10				3	3	3	3		
28	07 11 9919 965		ZYL SHR M 6 x 16						1	1		



Kurbelwelle  
Crankshaft  
Vilebrequin  
Vevaxel  
Albero a gomiti

BMW D 150 / D 190 / D 530 / D 636

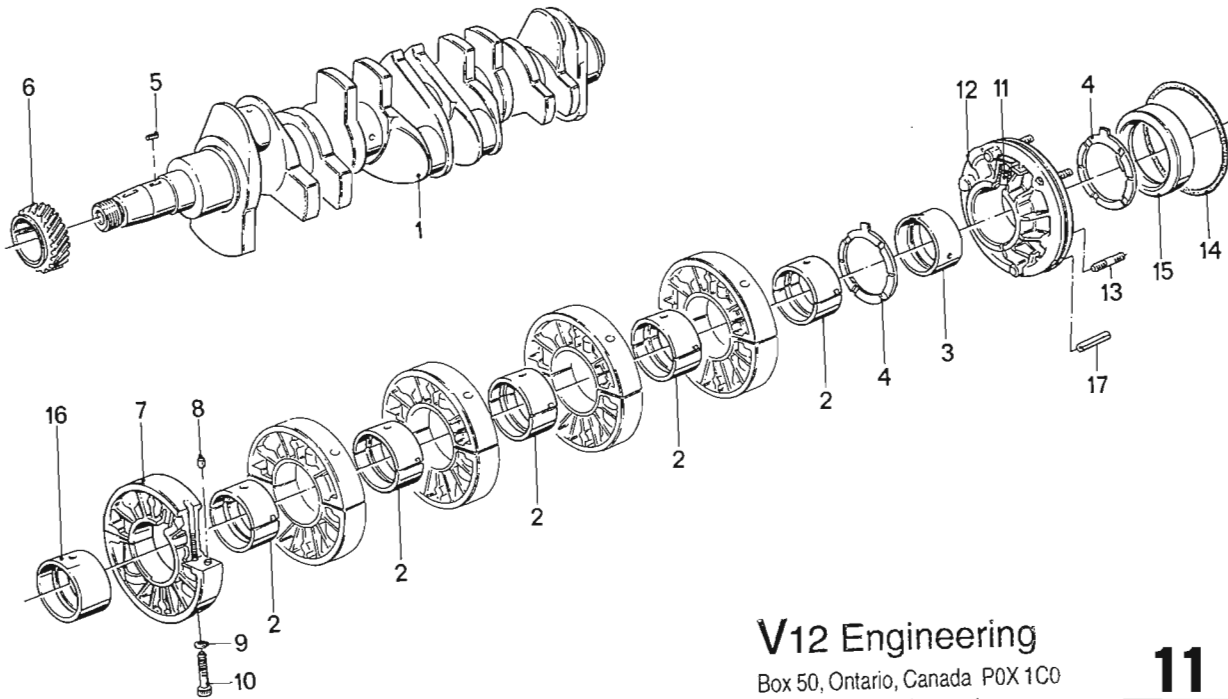

V12 Engineering

Box 50, Ontario, Canada POX 1C0  
[www.bmwmarine.net](http://www.bmwmarine.net)

11  
9/1

D 150/190/530/636  
4/86

11 9/1		4/86									
Nr.	Teile-Nummer	Symbol	Benennung	D 150	D 190	D 530	D 636	Bemerkung			
1	11 211 331 625 11 211 763 695 11 211 331 631		Kurbelwelle / Crankshaft / Vilebrequin / Vevaxel / Albero a gomiti dito	1	1	1	1				
2	11 211 331 632 11 211 331 633 11 211 331 635		0,00 Hauptlagerschale / Main bearing shell / Demi-coussinet de palier principal / Ramlägerskål / Semicuscinetto di banco	5	5	4	5				
3	11 211 331 636 11 211 331 637 11 211 331 639		+0,25 +0,50 0,00 Hauptlagerbüchse / Main bearing bushing / Coussinet de palier principal / Ramlagerbussning / Boccola del cuscinetto di banco	5 5 1	5 5 1	4 4 1	5 5 1				
4	11 211 331 640 11 211 331 641 11 211 331 642		-0,25 -0,50 0,00 Anlaufscheibe / Thrust washer / Rondelle d'entrainem. / Passbricka / Rosetta di arresto	1 1 2	1 1 2	1 1 2	1 1 2				
5	11 211 331 643 11 211 331 644		+0,10 +0,20 A 5 Paßfeder / Feather key / Ressort d'ajustage / Passkil / Chiavetta a molla d'adattam.	2 2 1	2 2 1	2 2 1	2 2 1				
6	11 211 331 647 11 211 331 648		Zahnrad / Toothed wheel / Rove dentée / Kugghjul / Ruota dentata kpl. Hauptlagerflansch innen / Main bearing flange inside / Bride de palier principal intérieur / Ramlagerfläns inre / Bride de palier Flangia interna del cuscinetto di banco	1 5	1 5	1 4	1 5				
8	11 211 331 647		ZYL STI	10	10	8	10				
9	07 119 932 110		B 10 Federscheibe / Spring washer / Rondelle élastique / Fjäderbricka / Rosetta elastica	10	10	8	10				
10	11 211 331 209		ZYL SHR	10	10	8	10				
11	11 211 331 649		kpl. Spritzdüse / Spraying nozzle / Gicleur / Spolmunstycke / Ugello spruzzatore	6	6	4	6				
12	11 211 331 652		Hauptlagerflansch hinten / Main bearing flange rear / Bride de palier principal arrière / Ramlagerfläns bakre / Flangia posteriore del cuscinetto di banco	1	1	1	1				
13	11 211 761 038		STI SHR M 8 x 20	6	6	6	6				
14	11 211 331 654		O-Ring / O-ring / Joint torique / O-ring / Anello-O	1	1	1	1				

V12 Engineering

Kurbelwelle  
Crankshaft  
Vilebrequin  
Vevaxel  
Albero a gomiti

BMW D 150 / D 190 / D 530 / D 636

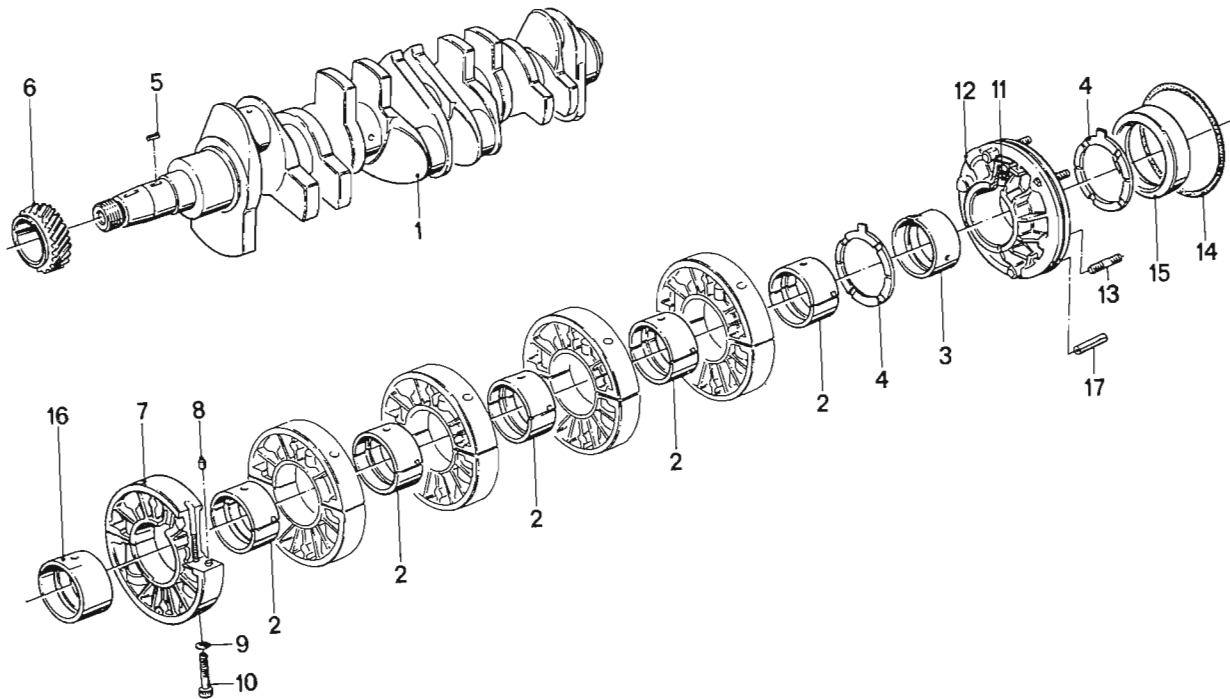

**11**  
**9/2**

D 150/190/530/636  
4/86

<b>11</b> <b>9/2</b>		4/86									
Nr.	Teile-Nummer	Symbol	Benennung	D 150	D 190	D 530	D 636	Bemerkung			
15	11 21 1 331 655		Weilendichtring / Shaft seal / Bague d'étanchéité radiale / Tätningring axel / Anello di tenuta	1	1	1	1				
16	11 11 1 331 627		0,00 Hauptlagerbüchse / Main bearing bushing / Coussinet de palier principal / Ramlagerbussning / Boccola del cuscinetto di banco	1	1	1	1				
	11 11 1 331 628		-0,25	1	1	1	1				
	11 11 1 331 629		-0,50	1	1	1	1				
17	07 11 9 941 485		SPN ST16 × 16	1	1	1	1				

Schwungradgehäuse  
Flywheel housing  
Carter de volant moteur  
Svånghjulskåpa  
Alloggiamento del volano

BMW D 150 / D 190 / D 530 / D 636

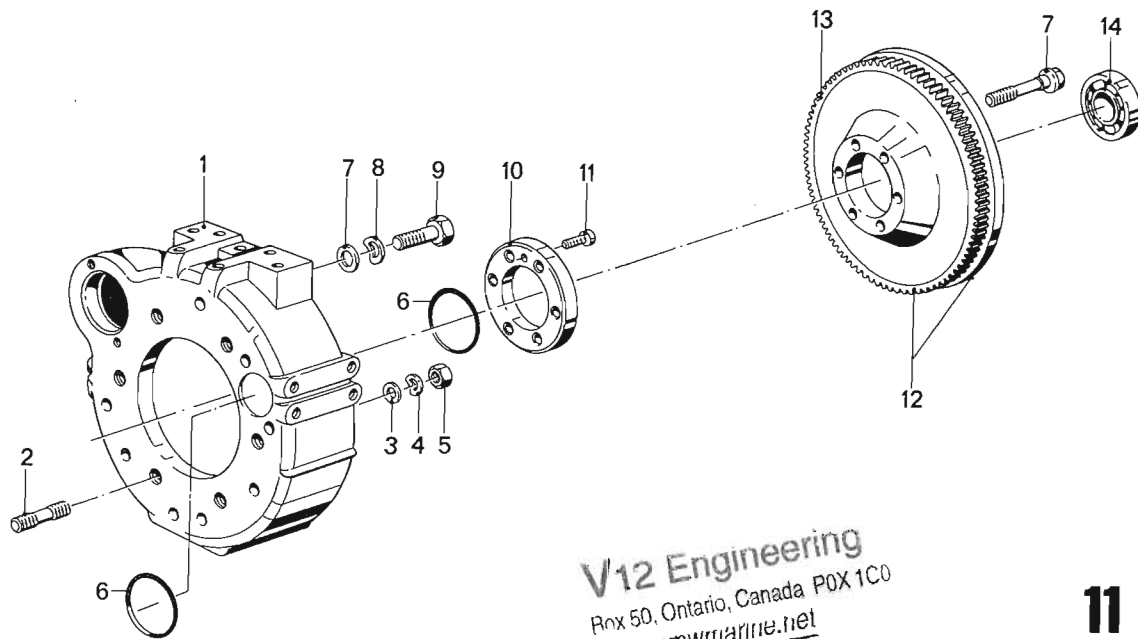

V12 Engineering  
Box 50, Ontario, Canada POX 1C0  
[www.bmwmarine.net](http://www.bmwmarine.net)

11  
10

D 150/190/530/636  
4/86

11 10		4/86									
Nr.	Teile-Nummer	Symbol	Benennung	D 150	D 190	D 530	D 636	Bemerkung			
1	11 22 1331 695		Schwungradgehäuse / Flywheel housing / Carter de volant moteur / Svånghjulskåpa / Alloggiamento del volano	1	1	1	1				
2	07 11 9908 402		STI SHR M 12 x 30	2	2	2	2				
3	07 11 9931 067		8,4 Scheibe / Washer / Rondelle / Bricka / Rondella	6	6	6	6				
4	07 11 9932 095		A8 Federscheibe / Spring washer / Rondelle élastique / Fjäderbricka / Rosetta elastica	6	6	6	6				
5	07 11 9922 087		6 KT MU M 8	6	6	6	6				
6	11 14 1331 619		O-Ring / O-ring / Joint torique / O-ring / Anello-O	2	2	2	2				
7	11 22 1331 703		Dehnschraube / Expansion bolt / Vis expansible / Skruv / Vite di espansione	6	6	6	6				
8	07 11 9932 112		B 10 Federring / Spring lock washer / Rondelle élastique / Fjäderbricka / Anello elastico	9	9	9	9				
9	07 11 9913 837		6 KT SHR M 10 x 30	9	9	9	9				
10	11 22 1331 697		Lauftring / Guide ring / Anneau de cours / Lagering / Anello di guida	1	1	1	1				
11	11 22 1331 698		Zentrierschraube / Centering screw / Vis de centrage / Centeringsskruv / Vite di centraggio	1	1	1	1				
12	11 22 1331 699		kpl. Schwungrad / Fly wheel / Volant du moteur / Svånghjul / Volans	1	1	1	1				
13	11 22 1331 701		Zahnkranz / Ring gear / Couronne dentée / Kuggkrans / Corona dentata	1	1	1	1				
14	11 22 1331 702		Kugellager / Ball bearing / Roulement à billes / Kullager / Cuscinetto a sfere	1	1	1	1				

V12 Engineering  
www.bmwmarine.com

Kolben  
Piston  
Pistón  
Kolv  
Pistone

BMW D 150 / D 190 / D 530 / D 636

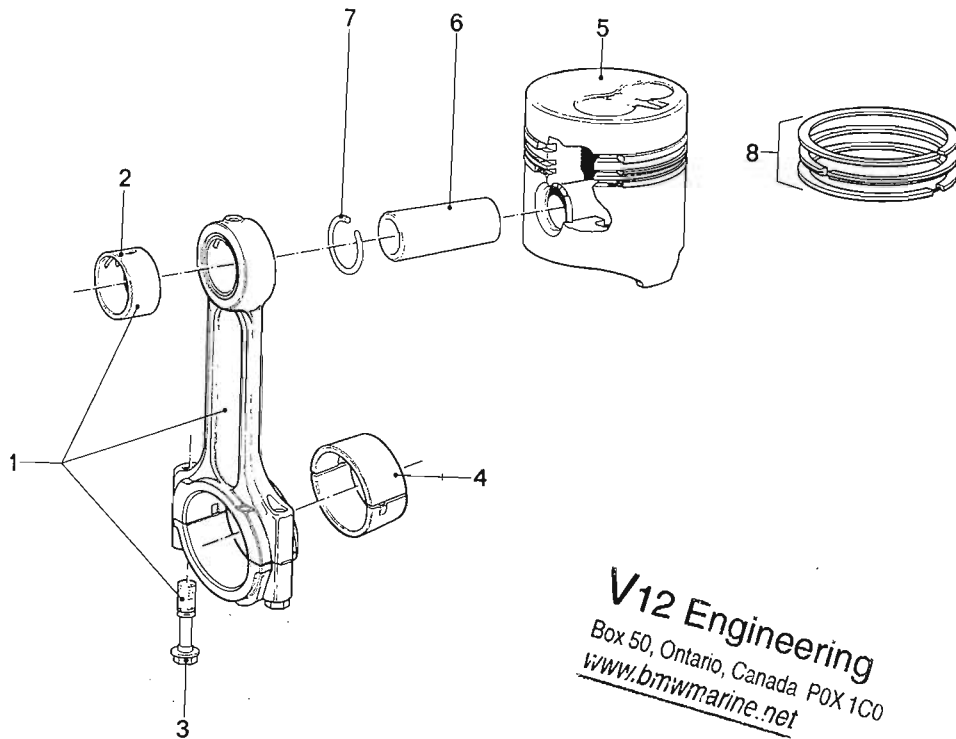

V12 Engineering  
Box 50, Ontario, Canada POX 1C0  
[www.bmwmarine.net](http://www.bmwmarine.net)

11  
11

D 150/190/530/636  
4/86

11 11		4/86									
Nr.	Teile-Nummer	Symbol	Benennung	D 150	D 190	D 530	D 636	Bemerkung			
1	11 24 1761 174		kpl. Pleuelstange / Connecting rod / Bielle / Vevstake / Biella E-Gewichtsgruppe / Weight group / Groupe de poids / Viktgrupp / Gruppo di peso	6	6	5	6				
	11 24 1761 175		F-dito	6	6	5	6				
	11 24 1761 176		G-dito	6	6	5	6				
	11 24 1761 177		H-dito	6	6	5	6				
	11 24 1761 178		J-dito	6	6	5	6				
	11 24 1763 238		I-dito	6	6	5	6				
	11 24 1763 239		M-dito	6	6	5	6				
	11 24 1763 240		L-dito	6	6	5	6				
2	11 24 1331 712		Buchse / Bushing / Manchon / Bussning / Boccola	6	6	5	6				
3	11 24 1331 713		Pleuelschraube / Connecting rod bolt / Boulon de bielle / Vevstaksbult / Bullone di biella	12	12	10	12				
4	11 24 1331 715		0,00 Lagerschale / Bearing shell / Coussinet / Ramlager / Guscio di cuscinetto	6	6	5	6				
	11 24 1331 716		-0,25	6	6	5	6				
	11 24 1331 717		-0,50	6	6	5	6				
5	11 25 1331 718		Ø92,0 kpl. Kolben / Piston / Pistón / Kolv / Pistone	6	6						
	11 25 1763 391		Ø92,0 dito			5	6				
	11 25 1331 726		Ø92,6 dito	6	6						
6	11 25 1331 724		Kolbenbolzen / Piston pin / Axe de piston / Kolv tapp / Spinotto del pistone	6	6						
	11 25 1763 393		dito			5	6				
7	11 25 1331 725		C30 Sprengring / Retaining ring / Rondelle grower / Stoppring / Anello elastico	12	12	10	12				
8	11 25 1331 720	RS	Ø 92 Kolbenring / Piston ring / Segment de piston / Kolvring / Segmento di pistone	6	6	5	6				
	11 25 1331 727	RS	Ø92,6	6	6						

V12 Engineering  
www.bmwmarine.com

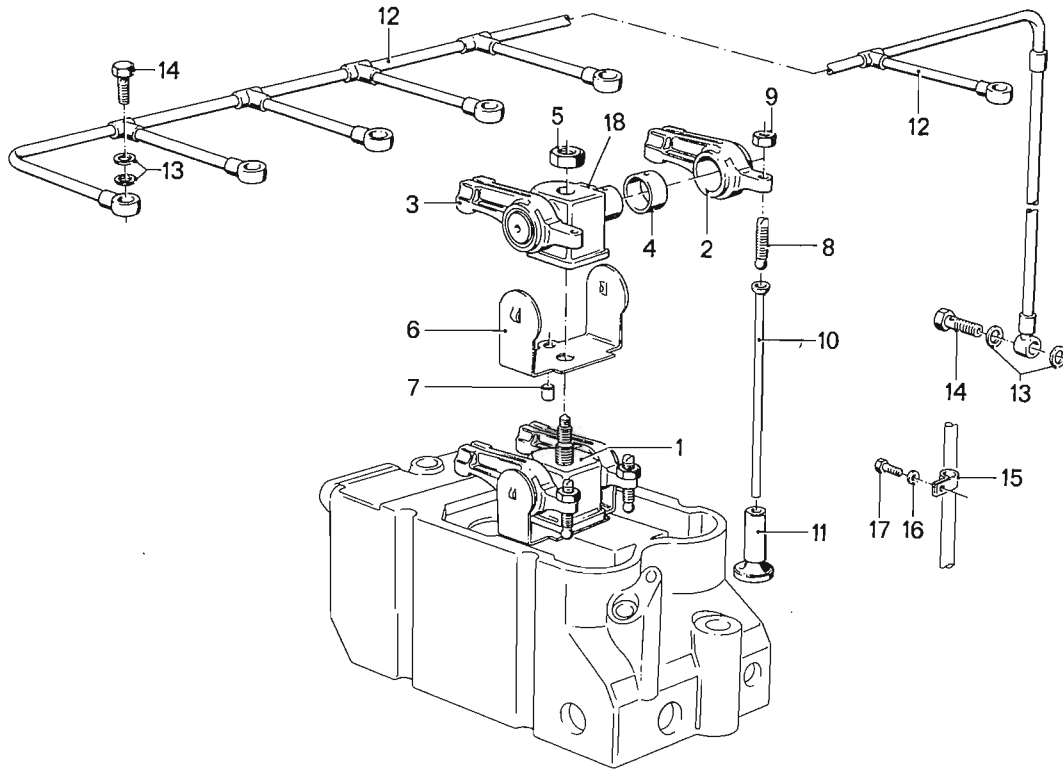

**11**  
**12**

D 150/190/530/636  
4/86

11 12		4/86					D 150	D 190	D 530	D 636	Bemerkung	
Nr.	Teile-Nummer	Symbol	Benennung	D 150	D 190	D 530	D 636					
1	11 33 1 331 739		kpl. Kipphebellagerbock / Rocker arm bearing bracket / Support de culbuteur / Vipparms lagerbock / Supporto bilanciare	6	6	5	6					
2	11 33 1 331 741		Kipphebel-Auslaß / Rocker arm, exhaust / Briquet, echappement / Vipparm, avgas / Bilanciere uscita	6	6	5	6					
3	11 33 1 331 742		Kipphebel-Einlaß / Rocker arm, intake / Briquet, admission / Vipparm, avgas / Bilanciere ammissione	6	6	5	6					
4	11 33 1 331 745		Lagerbüchse / Bearing bush / Coussinet / Lagerbussning / Boccola di supporto	12	12	10	12					
5	11 33 1 331 749		6 KT MU	6	6	5	6					
6	11 33 1 333 863		Bügel / Strap / Etrier / Bygel / Staffa	6	6	5	6					
7	11 33 1 331 748		Zentrierstift / Centering pin / Goupille de centrage / Centringsstift / Perno di centraggio	6	6	5	6					
8	11 33 1 331 746		Einstellschraube / Adjusting screw / Vis de réglage / Justerskruv / Vite di registrazione	12	12	10	12					
9	07 11 9 921 607		6 KT MU M 8 x 1	12	12	10	12					
10	11 32 1 331 738		Stoßstange / Tappet rod / Tige de poussoir / Stötstäng / Paraurti	12	12	10	12					
11	11 32 1 331 737		Stößel / Tappet / Poussoir / Ventilyftare / Punteria	12	12	10	12					
12	11 42 1 333 423		Druckölleitung / Hydraulic oil line / Conduite d'huile sous pression / Tryckoljeledning / Tubazione dell'olio in pressione	1	1		1					
	11 42 1 763 698		dito				1					
13	07 11 9 963 042		A 8 DTRG	14	14	12	14					
14	13 31 1 329 259		Hohlschraube / Banjo bolt / Vis creuse / Hålskruv / Vite cava	7	7	6	7					
15	11 42 1 333 424		Ø 8 Schelle / Coil clip / Collier / Klammer / Fascetta	1	1	1	1					
16	07 11 9 931 036		A 5,3 Scheibe / Washer / Rondelle / Bricka / Rondella	1	1	1	1					
17	07 11 9 913 218		6 KT SHR M 5 x 10	1	1	1	1					
18	11 33 1 331 740		Kipphebelbock / Rocker arm support / Support de culbuteur / Vipparmsbock / Supporto bilanciare	6	6	5	6					

www.bmwmarine.com

V12 Engineering

Nockenwelle, Ölpumpe  
 Camshaft, Oil pump  
 Arbre à cames, Pompe à huile  
 Kamaxel, Oliepump  
 Albero a camme, Pompa olio

BMW D 150 / D 190 / D 530 / D 636

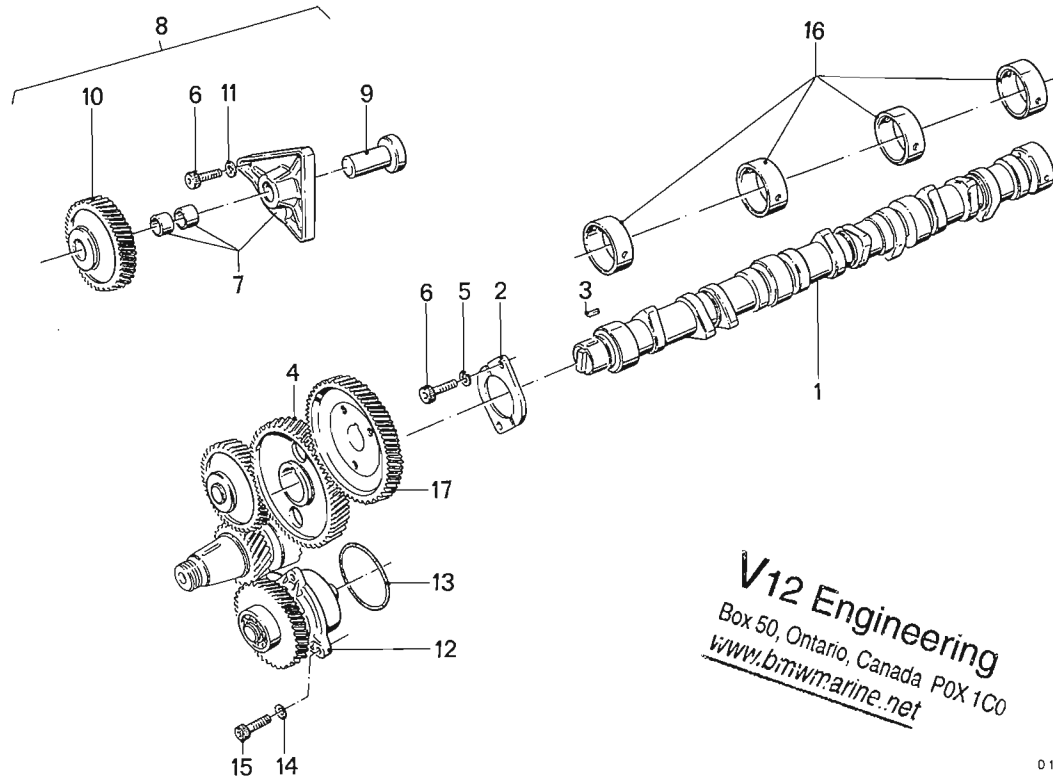

V12 Engineering  
 Box 50, Ontario, Canada POX 1C0  
[www.bmwmarine.net](http://www.bmwmarine.net)

**11**  
**13**

D 150/190/530/636  
4/86

11 13		4/86											
Nr.	Teile-Nummer	Symbol	Benennung	D 150	D 190	D 530	D 636	Bemerkung					
1	1131 1331 734 1131 1763 394 1131 1763 696		Nockenwelle / Camshaft / Arbre à cames / Kamaxel / Albero a camme dito dito	1	1								
2	1131 1331 733		Führungsblech / Guide plate / Tôle de guidage / Styrbleck / Lamiera di guida	1	1	1	1						
3	1131 1331 735		Paßfeder / Feather key / Ressort d'ajustage / Passkil / Chiavetta a molla d'adattam.	1	1	1	1						
4	1131 1331 736		Zahnrad / Toothed wheel / Roue dentée / Kuggjul / Ruota dentata	1	1	1	1						
5	07 119933 096		B8 Federscheibe / Spring washer / Rondelle élastique / Fjäderbricka / Rosetta elastica	2	2	2	2						
6	07 119919 940		ZYL SHR M 8 x 18	5	5	5	5						
7	1135 1333 881		kpl. Grundplatte / Base plate / Plateau / Plaatta / Piastra di attacco	1	1	1	1						
8	1135 1333 400		kpl. Zwischenantrieb / Intermediate drive / Commande intermédiaire / Mellandrif / Azionamento intermedio	1	1	1	1						
9	1135 1333 402		Steckachse / Rear axle / Arbre enfichable / Stickbar axel / Semialbero	1	1	1	1						
10	1135 1333 404		Zahnrad / Toothed wheel / Roue dentée / Kuggjul / Ruota dentata	1	1	1	1						
11	07 119931 660		8,4 Scheibe / Washer / Rondelle / Bricka / Rondella	3	3	3	3						
12	1141 1333 406		kpl. Ölpumpe / Oil pump / Pompe à huile / Oliepump / Pompa olio	1	1	1	1						
13	1141 1333 412		O-Ring / O-ring / Joint torique / O-ring / Anello-O	1	1	1	1						
14	07 119932 095		B8 Federscheibe / Spring washer / Rondelle élastique / Fjäderbricka / Rosetta elastica	3	3	3	3						
15	07 119919 940		ZYL SHR M 8 x 18	3	3	3	3						
16	11 11 1331 731		0,00 Nockenwellenlagerbüchse / Camshaft bearing bushing / Coussinet de palier d'arbre à cames / Bussning, kamaxellager / Boccola dell'albero a camme	4	4	3	4						
	11 11 1333 864		-0,25 dito	4	4	3	4						
17	1352 1331 224		Zahnrad / Toothed wheel / Roue dentée / Kuggjul / Ruota dentata	1	1	1	1						

V12 Engineering  
 www.bmwmarine.com

Wasserpumpe  
Water pump  
Pompe d'eau  
Vattenpump  
Pompa acqua

BMW D 150 / D 190 / D 530 / D 636

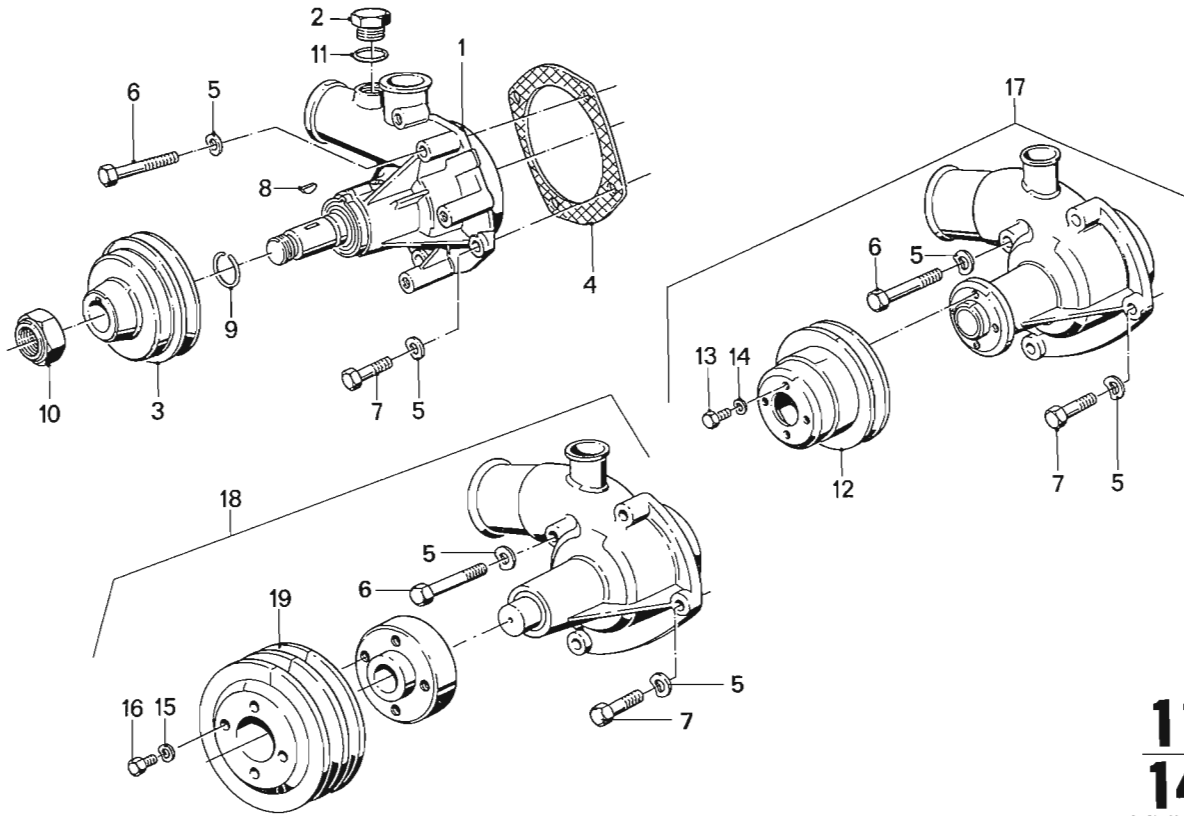

**11**  
**14**

D 150/190/530/636  
4/86

11 14		4/86											
Nr.	Teile-Nummer	Symbol	Benennung	D 150	D 190	D 530	D 636	Bemerkung					
1	a 11 51 1 333 435		kpl. Wasserpumpe / Water pump / Pompe d'eau / Vattenpump / Pompa acqua	1									
2	07 119 919 246		VSL SHR M 18 x 1,5	1	1								
3	a 11 51 1 333 437		Riemenscheibe / Belt pulley / Poulie de courroie / Remskiva / Puleggia	1									
4	11 51 1 333 441		Dichtung / Seal / Garniture / Packning / Guarnizione	1	1	1	1						
5	a 07 119 932 095		B 8 Federscheibe / Spring washer / Rondelle élastique / Fjäderbricka / Rosetta elastica	4	4	4	4						
6	a 07 119 912 506		6 KT SHR M 8 x 45	2	2	2	2						
7	a 07 119 913 657		6 KT SHR M 8 x 25	2	2	2	2						
8	a 11 51 1 333 438		3 x 5 Scheibfeder / Disk spring / Ressort en rondelle / Planfjäder / Molla per disco	1									
9	a 11 51 1 333 439		Sprengring / Retaining ring / Rondelle grower / Stoppring / Anello elastico	1									
10	a 11 51 1 333 440		6 KT MU M 14 x 1,5	1									
11	a 07 119 963 308		D TRG	1									
12	b 11 51 1 761 182		Riemenscheibe / Pulley / Poulie / Remskiva / Puleggia	1	1		1						
13	b 07 119 913 426		6 KT SHR M 6 x 10	4	4								
14	b 07 119 932 070		B 6 Federscheibe / Spring washer / Rondelle élastique / Fjäderbricka / Rosetta elastica	4	4								
15	07 119 932 072		Federscheibe / Spring washer / Rondelle élastique / Fjäderbricka / Rosetta elastica			4	4						
16	07 119 913 410		6 KT SHR			4	4						
17	b 11 51 1 761 147		kpl. Wasserpumpe / Water pump / Pompe d'eau / Vattenpump / Pompa acqua	1	1								
18	11 51 1 763 297		kpl. dito			1	1						
19	11 51 1 763 298		Riemenscheibe / Pulley / Poulie / Remskiva / Puleggia			1	1						

a) → Aggr. Nr. 434 (D150)  
b) Aggr. Nr. → dito (D150)

V12 Engineering  
Box 50, Ontario, Canada POX 1C0  
www.d7rwinmarine.net

V12 Engineering  
www.d7rwinmarine.net

Abgassammler  
Exhaust plenum chamber  
Collecteur d'échappement  
Avgassammlare  
Collettore gas di scarico

BMW D 150 / D 190 / D 530 / D 636

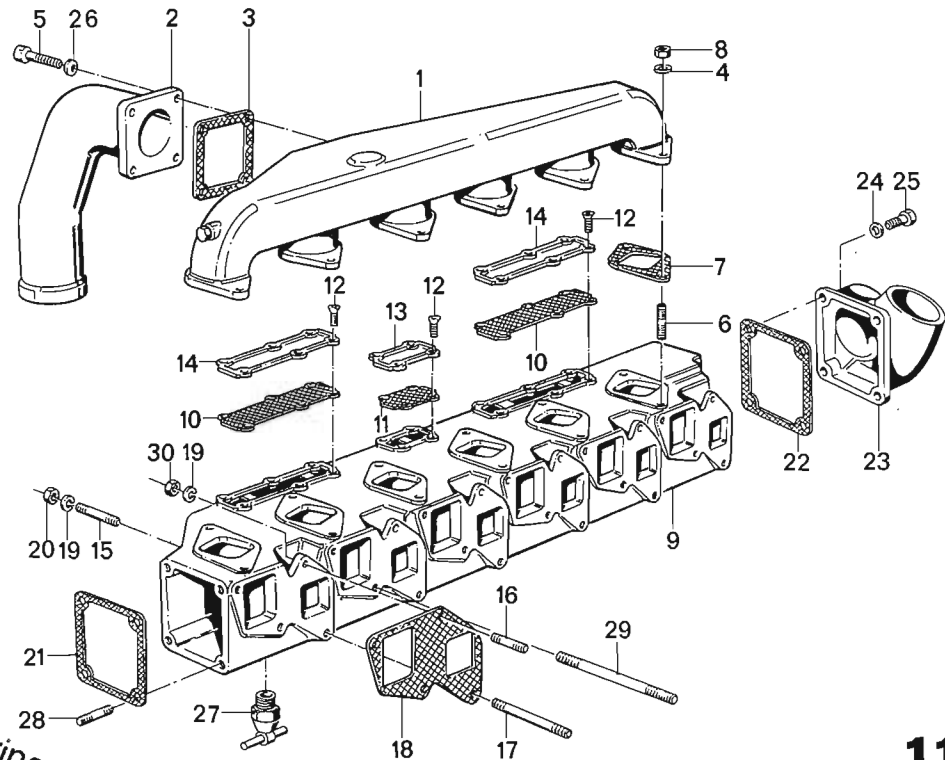

V12 Engineering  
Box 50, Ontario, Canada P0X 1C0  
www.bmwmarine.net

11  
15/1  
D 150/190  
4/86

11 15/1		4/86					D 150	D 190	D 530	D 636	Bemerkung
Nr.	Teile-Nummer	Symbol	Benennung	D 150	D 190	D 530	D 636				
1	11 611 333 467		Ansaugsammler / Intake manifold / Collecteur d'admission / Insugnings samlare / Collettore di aspirazione	1							
2	11 611 333 468		Krümmer / Elbow / Coude / Slang / Gomito	1							
3	11 611 333 469		Dichtung / Seal / Garniture / Packning / Guarnizione	1							
4	07 119 932 095		B 8 Federscheibe / Spring washer / Rondelle élastique / Fjäderbricka / Rosetta elastica	12	12		12				
5	07 119 919 781		ZYL SHR M 6 × 18	4							
6	07 119 909 054		STI SHR M 8 × 16	6	6						
7	11 611 333 472		Dichtung / Seal / Garniture / Packning / Guarnizione	6	6		6				
8	07 119 921 077		6 KT MU M 8	12	12		12				
9	11 621 761 824		kpl. Abgassammler / Exhaust plenum chamber / Collecteur d'échappement / Avgassammlare / Collettore gas di scarico	1	1						
10	11 621 761 826		Dichtung / Seal / Garniture / Packning / Guarnizione	4	4						
11	11 621 333 446		dito	1	1						
12	07 119 900 816		SK SHR M 6 × 16	36	36						
13	11 621 331 178		Deckel / Cover / Couvercle / Lock / Coperchio	1	1						
14	11 621 761 825		dito	4	4						
15	11 621 333 451		STI SHR M 8 × 90	2	2		2				
16	07 119 908 310		STI SHR M 8 × 20	7	7		6				
17	11 621 333 448		STI SHR M 8 × 140	13	13		12				
18	11 621 333 449		Dichtung / Seal / Garniture / Packning / Guarnizione	6	6		6				
19	07 119 930 840		B 8 Federring / Spring lock washer / Rondelle élastique / Fjäderbricka / Anello elastico	24	24		24				
20	11 621 761 715		6 KT MU M 8	12	12						
21	17 111 761 083		Dichtung / Seal / Garniture / Packning / Guarnizione	1	1	1	1				
22	11 621 761 084		dito	1	1						
23	11 621 331 141		Deckel / Cover / Couvercle / Lock / Coperchio	1	1						
24	07 119 931 067		A 8,4 Scheibe / Washer / Rondelle / Bricka / Rondella	2	2						
25	07 119 919 969		ZYL SHR M 8 × 20	2	2						
26	07 119 932 072		B 6 Federscheibe / Spring washer / Rondelle élastique / Fjäderbricka / Rosetta elastica	4	4						

V12 Engineering  
www.bmwmarine.com



Abgassammler  
 Exhaust plenum chamber  
 Collecteur d'échappement  
 Avgassammlare  
 Collettore gas di scarico

BMW D 150 / D 190 / D 530 / D 636

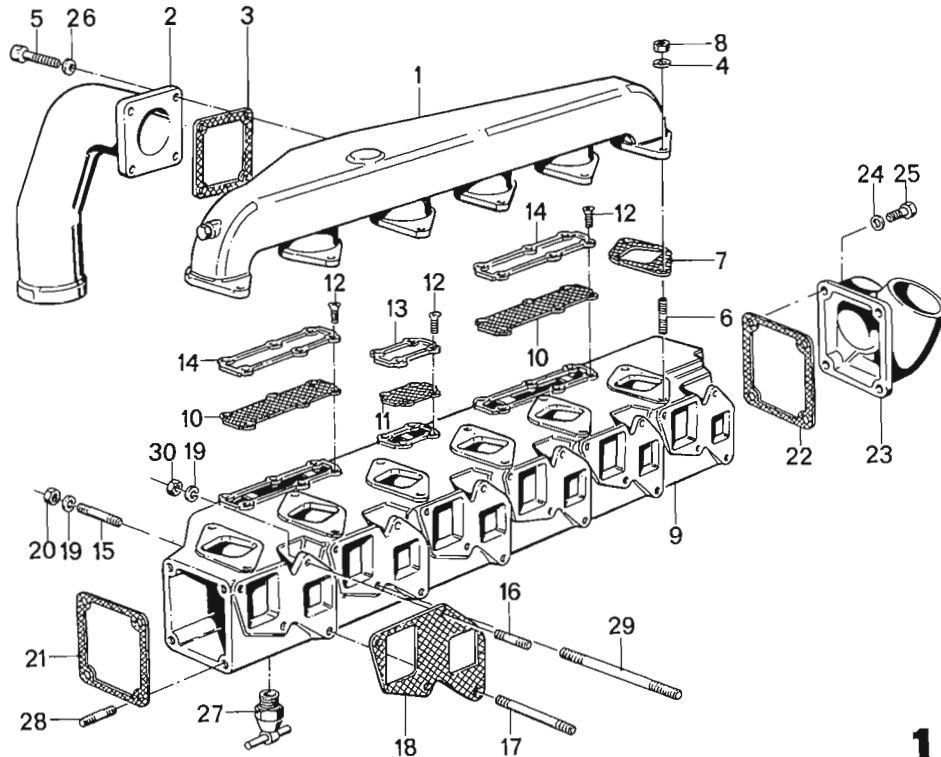

**11**  
**15/2**  
 D 150/190  
 4/86

11 15/2		4/86									
Nr.	Teile-Nummer	Symbol	Benennung	D 150	D 190	D 530	D 636	Bemerkung			
27	11 11 1 331 684		Ablaßhahn / Drain cock / Robinet de vidange / Utloppskran / Rubinetto di scarico	1	1	1					
28	07 11 9 909 067		STISHRM 8 x 20	4	4	4					
29	11 62 1 761 772		STISHRM 8 x 150	2	2	4					
30	11 62 1 333 450		6 KTMUM 8	12	12	24					

V12 Engineering

www.bmwmarine.com

Abgassammler  
 Exhaust plenum chamber  
 Collecteur d'échappement  
 Avgassammlare  
 Collettore gas di scarico

BMW D 150 / D 190 / D 530 / D 636

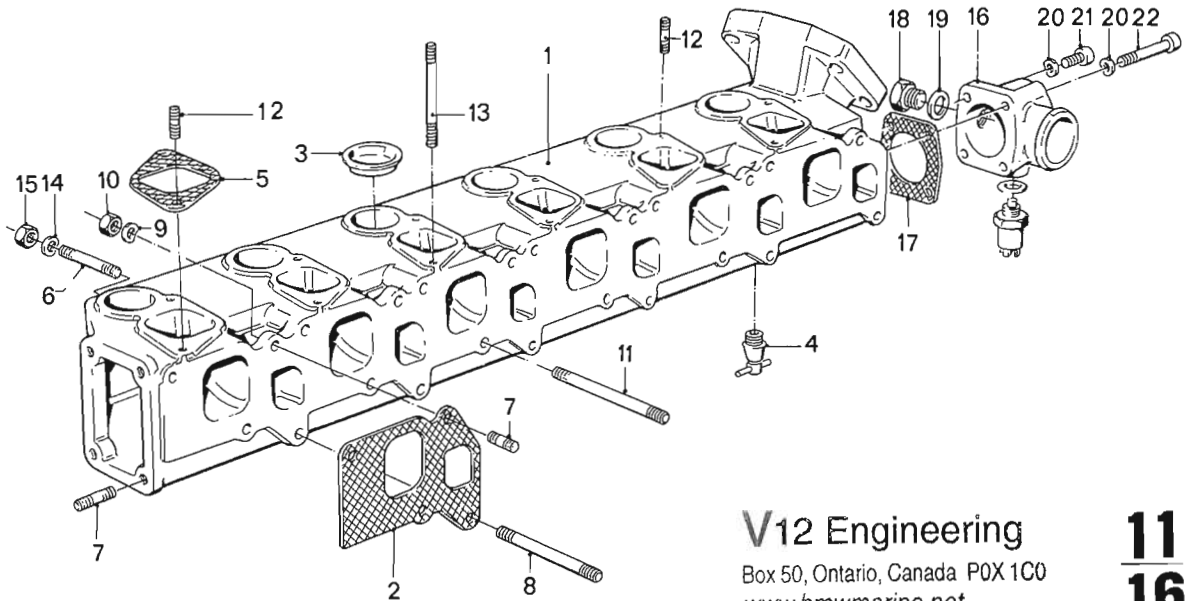

V12 Engineering

Box 50, Ontario, Canada P0X 1C0  
[www.bmwmarine.net](http://www.bmwmarine.net)

**11**  
**16**  
 D 530/636  
 4/86

11 16		4/86											
Nr.	Teile-Nummer	Symbol	Benennung	D 150	D 190	D 530	D 636					Bemerkung	
1	11 62 1 763 438		Abgassammler / Exhaust plenum chamber / Collecteur d'échappement / Avgassammlare / Collettore gas di scarico									1	
	11 62 1 763 700		dito										
2	11 62 1 333 449		Dichtung / Seal / Garniture / Packning / Guarnizione	6	6	5	6						
3	11 62 1 763 439		Ø 36 Verschlussdeckel / Blanking cover / Couvercle d'obturation / Täcklock / Coperchio di chiusura			9	9						
4	11 11 1 331 684		Ablaßhahn / Drain cock / Robinet de vidange / Utloppskran / Rubinetto di scarico	1	1	1	1						
5	11 61 1 333 472		Dichtung / Seal / Garniture / Packning / Guarnizione	6	6	5	6						
6	11 62 1 333 451		STI SHR M 8 x 90	2	2	2	2						
7	07 11 9908 310		STI SHR M 8 x 20	6	6	5	6						
8	11 62 1 333 448		STI SHR M 8 x 140	12	12	9	12						
9	07 11 9932 093		B 8 Federscheibe / Spring washer / Rondelle élastique / Fjäderbricka / Rosetta elastica	24	24	18	24						
10	11 62 1 333 450		6 KT MU M 8	12	12	18	12						
11	11 62 1 761 772		STI SHR M 8 x 150	2	2	4	4						
12	11 62 1 763 443		STI SHR M 8 x 16			6	7						
13	11 62 1 763 444		STI SHR M 8 x 100			4	5						
14	07 11 9932 095		B 8 Federscheibe / Spring washer / Rondelle élastique / Fjäderbricka / Rosetta elastica	20	20	12	20						
15	07 11 9921 077		6 KT SHR M 8	12	12	12	12						
16	11 62 1 763 444		Deckel / Cover / Couvercle / Lock / Coperchio										1
17	11 62 1 763 472		Dichtung / Seal / Garniture / Packning / Guarnizione			1	1						
18	11 62 1 763 445		VSL SHR M 12 x 1,5			1	1						
19	11 43 1 763 492		DTRG			1	1						
20	07 11 9932 072		B 6 Federscheibe / Spring washer / Rondelle élastique / Fjäderbricka / Rosetta elastica			4	4						
21	07 11 9919 926		ZYL SHR M 6 x 25			2	2						
22	07 11 9919 961		ZYL SHR M 6 x 60			2	2						

V12 Engineering  
 www.bmwmarine.com

Ladeluftkühler  
Load air cooler  
Refrroidisseur d'air de suralimentation  
Kylare för laddningsluft  
Refr. aria sovrallim

BMW D 150 / D 190 / D 530 / D 636

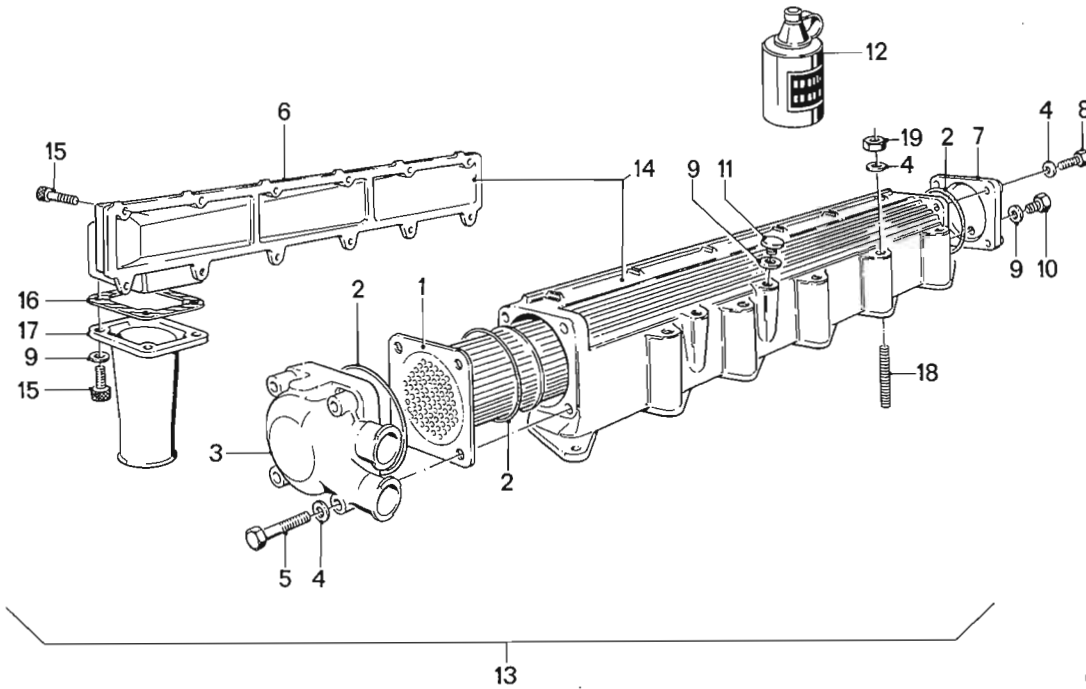

**11**  
**17**  
D 150/D 190  
4/86

<b>11</b> <b>17</b>		4/86							
Nr.	Teile-Nummer	Symbol	Benennung	D 150	D 190	D 530	D 636	Bemerkung	
1	11 65 1761 367		Kühlereinsatz / Radiator insert / Element de radiateur / Radioatorinsats / Inserzione radiatore		1		1		
2	11 65 1761 102		O-Ring / O-ring / Joint torique / O-ring / Anello-O		3				
3	11 65 1761 360		Deckel vorne / Cover front / Couvercle avant / Lock fram / Coperchio anteriore, avanti		1				
4	07 11 9932 095		B 8 Federscheibe / Spring washer / Rondelle élastique / Fjäderbricka / Rosetta elastica		20		20		
5	07 11 9912 516		6 KT SHR M 8 × 50		4		2		
6	11 65 1761 364		Deckel / Cover / Couvercle / Lock / Coperchio		1				
7	11 65 1761 361		dito hinten / rear / arrière / bak / Posteriore, dietro		1				
8	07 11 9913 657		6 KT SHR M 8 × 25		4				
9	07 11 9963 072		DTRG		5				
10	17 11 1763 262		VSL SHR M 10 × 1		1				
11	07 11 9919 112		VSL SHR M 10 × 1		1				
12	07 58 9056 979		Flüssigdichtmittel / Liquid sealing material / Produit liquide d'étanchéité / Flytande tättningsmedel / Materiale sigillante liquido		1		1		
13	11 65 1761 730		kpL. Ladeluftkühler / Load air cooler / Refroidisseur d'air de suralimentation / Kylare för laddningsluft / Refr. aria sovrallim		1				
14	11 65 1761 362		Kühlergehäuse / Radiator casing / Boitier de radiateur / Kylarkåpa / Telaio del radiatore		1				
15	07 11 9919 967		ZYL SHR M 6 × 20		12		12		
16	11 65 1761 365		Dichtung / Seal / Garniture / Packing / Guarnizione		1				
17	11 65 1761 366		Stutzen / Connection / Tubulure / Stuts / Bocchettone		1				
18	07 11 9909 106		STI SHR M 8 × 100		6		6		
19	07 11 9921 077		6 KT MU M 8		12		12		

www.bmw-engineering.com

Ladeluftkühler  
Load air cooler  
Refrroidisseur d'air de suralimentation  
Kylare för laddningsluft  
Refr. aria sovralim

BMW D 150 / D 190 / D 530 / D 636

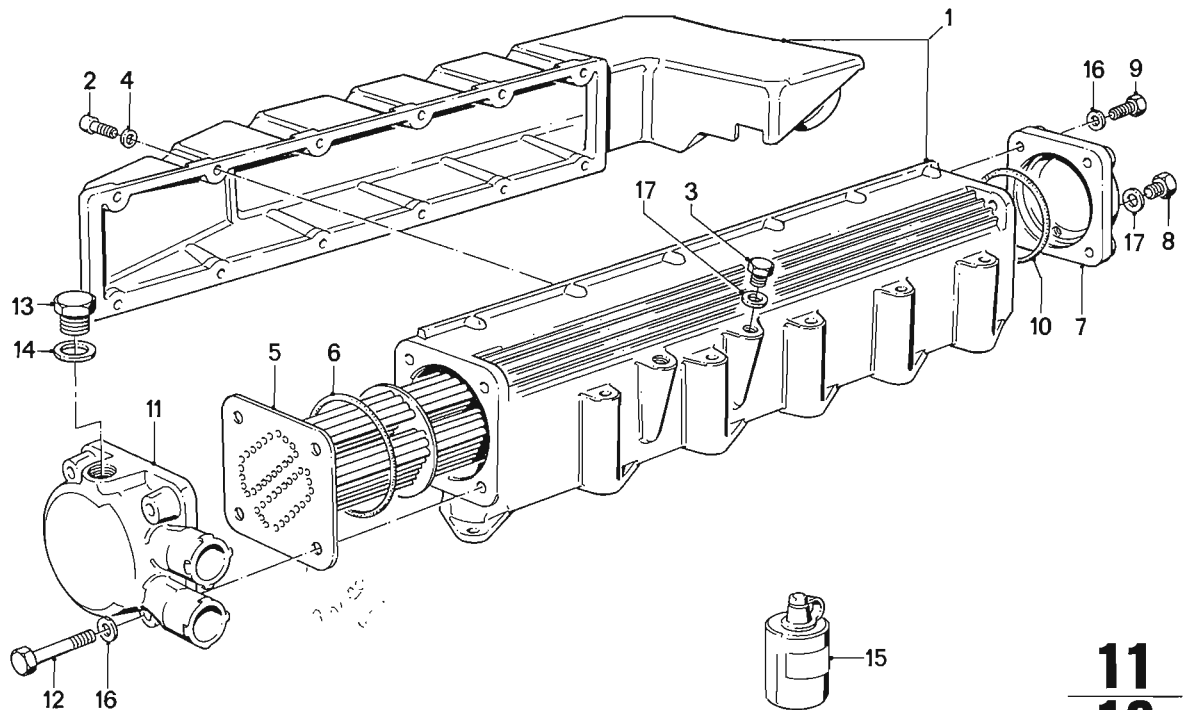

**11**  
**18**

D 530/636  
4/86

<b>11</b> <b>18</b>		4/86						
Nr.	Teile-Nummer	Symbol	Benennung	D 150	D 190	D 530	D 636	Bemerkung
1	11 65 1 763 457		Ladeluftkühler / Load air cooler / Refroidisseur d'air de suralimentation / Kylare för laddningsluft / Refr. aria sovralim				1	
	11 65 1 763 702		dito			1		
2	07 11 9 919 967		ZYL SHR M 6 × 20		12	10	12	
3	07 11 9 919 217		VSL SHR M 10 × 1			1	1	
4	07 11 9 932 072		B 6 Federscheibe / Spring washer / Rondelle élastique / Fjäderbricka Rosetta elastica		14	10	14	
5	11 65 1 761 367		Kühlereinsatz / Radiator insert / element de radiateur / Radiatorinsatz / Inserzione radiatore		1		1	
	11 65 1 763 705		dito			1		
6	11 65 1 763 461		O-Ring / O-ring / Joint torique / O-ring / Anello-O			4	4	
7	11 65 1 763 463		Deckel hinten / Cover rear / Couvercle arrière / Lock bak / Coperchio posteriore, dietro			1	1	
8	11 65 1 763 459		VSL SHR M 10 × 1,25			1	1	
9	07 11 9 913 662		6 KT SHR M 8 × 25			6	6	
10	11 65 1 763 488		Scheibe / Washer / Rondelle / Bricka / Rondella			1	1	
11	11 65 1 761 360		Deckel vorne / Cover front / Couvercle avant / Lock fram / Coperchio anteriore, avanti		1	1	1	
12	07 11 9 912 516		6 KT SHR M 8 × 50			2	2	
13	11 65 1 763 331		VSL SHR			1	1	
14	07 11 9 963 308		DTRG A 18			1	1	
15	07 58 9 056 979		Dichtmittel / Sealing material / Moyen d'étanchéité / Tättningsmedel / Materiale sigillante		1	1	1	
16	07 11 9 932 095		B 8 Federscheibe / Spring washer / Rondelle élastique / Fjäderbricka Rosetta elastica			6	6	
17	07 11 9 963 072		DTRG			2	2	

V12 Engineering  
Box 50 Ontario, Canada POX 1C0  
www.bmwmarine.net

Turbolader  
 Turbo charger  
 Turbocompresseur  
 Turbokompressor  
 Turbo compressore di sovralimentazione

BMW D 150 / D 190 / D 530 / D 636

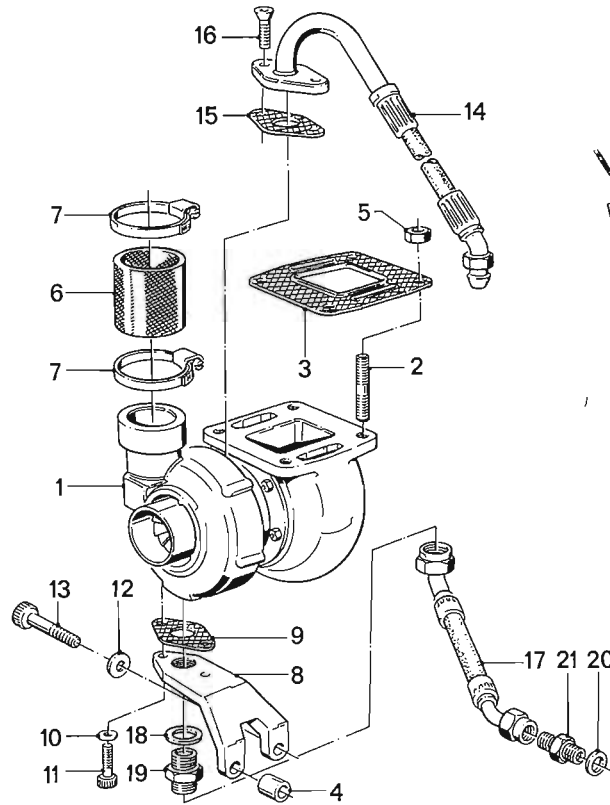

V12 Engineering  
 Box 50, Ontario, Canada POX 1C0  
 www.v12engineering.net

DS-22

11  
 19  
 D 150/D 190  
 4/86

11 19		4/86									
Nr.	Teile-Nummer	Symbol	Benennung	D 150	D 190	D 530	D 636	Bemerkung			
1	11 65 1 333 452		kpl. Abgasturbolader / Exhaust gas turbocharger / Turbocompresseur à gaz d'échappement / Avgasturbokompressor / Turbocompressore azionato dai gas di scarico	1	1						
2	11 65 1 333 453		STI SHR M 10 × 30	4	4		4				
3	11 65 1 333 454		Dichtung / Seal / Garniture / Packning / Guarnizione	1	1	1	1				
4	11 81 1 761 559		Distanzbuchse / Spacer socket / Douille d'écartement / Distanshylsa / Boccia distanziatore	1	1						
5	11 65 1 333 455		6 KT MU M 10	4	4						
6	11 65 1 333 456		Verbindungsschlauch / Connecting hose / Flexible de raccordement / Slangförbinding / Tubo flessibile di collegamento	1	1						
7	11 65 1 333 457		50-64 Schelle / Slamp / Collier / Klämme / Fascetta	2	2						
8	11 65 1 333 458		Abstützung / Propp / Support / Stöttning / Supporto	1	1						
9	11 65 1 333 459		Dichtung / Seal / Garniture / Packning / Guarnizione	1	1	2	2				
10	07 11 9 932 095		B 8 Federscheibe / Spring washer / Rondelle élastique / Fjäderbricka / Rosetta elastica	2	2						
11	07 11 9 919 644		ZYL SHR M 8 × 35	2	2						
12	07 11 9 931 076		B 10 Federring / Spring lock washer / Rondelle élastique / Fjäderbricka / Anello elastico	1	1						
13	07 11 9 912 672		ZYL SHR M 10 × 70	1	1						
14	11 65 1 333 461		Öldruckschlauch / Oil pressure hose / Flexible d'huile sous pression / Oljetrycksslang / Tubo flessibile di olio in pressione	1	1						
15	11 65 1 333 462		Dichtung / Seal / Garniture / Packning / Guarnizione	1	1	1	1				
16	11 65 1 331 207		SK SHR M 8 × 20	2	2						
17	11 65 1 333 463		Öldruckschlauch / Oil pressure hose / Flexible d'huile sous pression / Oljetrycksslang / Tubo flessibile di collegamento	1	1						
18	07 11 9 963 354		A 22 DTRG	1	1		2				
19	11 65 1 333 466		Verbindungsnippel / Connecting nipple / Raccord fileté / Förbindningsnippel / Nipplo di raccordo	1	1						
20	07 11 9 963 342		DTRG	1	1						
21	11 65 1 333 464		Verbindungsnippel / Connecting nipple / Raccord fileté / Förbindningsnippel / Nipplo di raccordo	1	1						
22	11 65 1 331 187	DS	Abgasturbine / Exhaust gas turbine / Turbine à gaz d'échappement / Turbina a gas di scarico	1	1	1	1				

www.v12engineering.net

Turbolader  
 Turbo charger  
 Turbocompresseur  
 Turbokompressor  
 Turbo compressore di sovralimentazione

BMW D 150 / D 190 / D 530 / D 636



V12 Engineering  
 Box 50, Ontario, Canada POX 1C0  
 www.bmwmarine.net

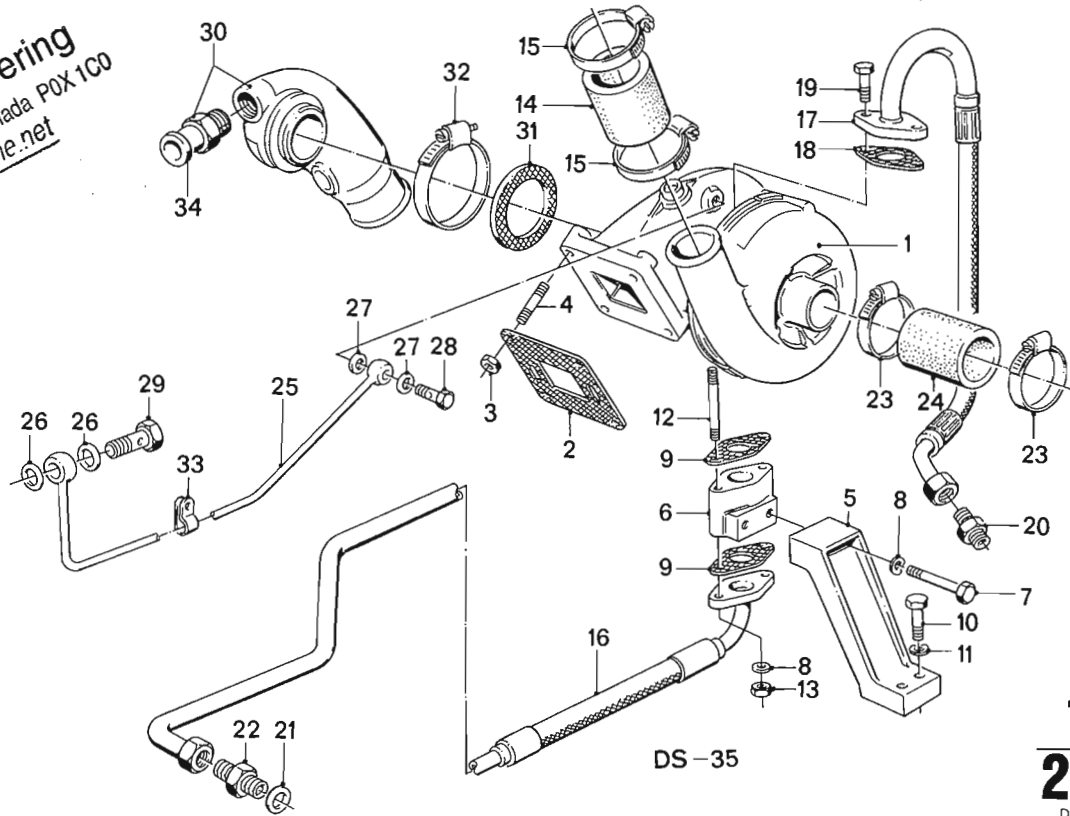

DS-35

**11**  
**20/1**  
 D 530/636  
 4/86

11 20/1		4/86					D 150	D 190	D 530	D 636	Bemerkung
Nr.	Teile-Nummer	Symbol	Benennung								
1	1165 1763 447		kpl. Turbolader / Turbo charger / Turbocompresseur / Turbokompressor / Turbo compressore di sovralimentazione						1		
	1165 1763 701		dito					1			
2	1165 1333 454		Dichtung / Seal / Garniture / Packning / Guarnizione	1	1	1	1				
3	1165 1763 448		6 KT MU				4	4			
4	1165 1333 453		STI SHR M 10 x 30	4	4	4	4				
5	1165 1763 449		Halter / Support / Support / Fäste / Sostegno				1	1			
6	1165 1763 450		Distanzstück / Spacer / Pièce d'écartement / Distanzstycke / Pezzo distanziatore				1	1			
7	07 11 9912 535		6 KT SHR M 8 x 65				2	2			
8	07 11 9932 095		B 8 Federscheibe / Spring washer / Rondelle élastique / Fjäderbricka / Rosetta elastica				4	4			
9	1165 1333 459		Dichtung / Seal / Garniture / Packning / Guarnizione		1	2	2				
10	07 11 9919 669		Zyl. SHR M 10 x 35				2	2			
11	07 11 9932 104		A 10 Federscheibe / Spring washer / Rondelle élastique / Fjäderbricka / Guarnizione				2	2			
12	1165 1763 451		STI SHR M 8 x 70				2	2			
13	07 11 9922 087		6 KT SHR M 8				2	2			
14	1165 1333 456		Verbindungsschlauch / Connecting hose / Flexible de raccordement / Slangförbindng / Tubo flessibile di collegamento	1	1	1	1				
15	1165 1333 457		50-64 Schelle / Clamp / Collier / Klämna / Fascetta	2	2	2	2				
16	1165 1763 456		Ölleitung / Oil pipe / Conduite d'huile / Oljeledning / Tubatura olio						1		
	1165 1763 778		dito					1			
	1165 1763 455		dito					1	1		
18	1165 1333 462		Dichtung / Seal / Garniture / Packning / Guarnizione		1	1	1	1			
19	07 11 9913 644		6 KT SHR M 8 x 20				2	2			
20	11 21 1763 389		Rohrverschraubung / Pipe union piece / Tuyau d'échappement / Rörförskruvning / Giunto filettato per tubazioni				1	1			
21	07 11 9963 354		A 22 DF RG					1	1		
22	1165 1333 464		M 22 x 1,5 Schraubstutzen / Threaded socket / Raccord fileté / Skruvmuff / Bocchettone filettato					1	1		
23	1153 1328 048		40-60 Schelle / Clamp / Collier / Klämna / Fascetta				2	2			
24	17 11 1761 273		Stutzen / Connection / Tubulure / Stuts / Bocchettone				1	1			

V12 Engineering  
 www.bmwmarine.com

Turbolader  
 Turbo charger  
 Turbocompresseur  
 Turbokompressor  
 Turbo compressore di sovralimentazione

BMW D 150 / D 190 / D 530 / D 636

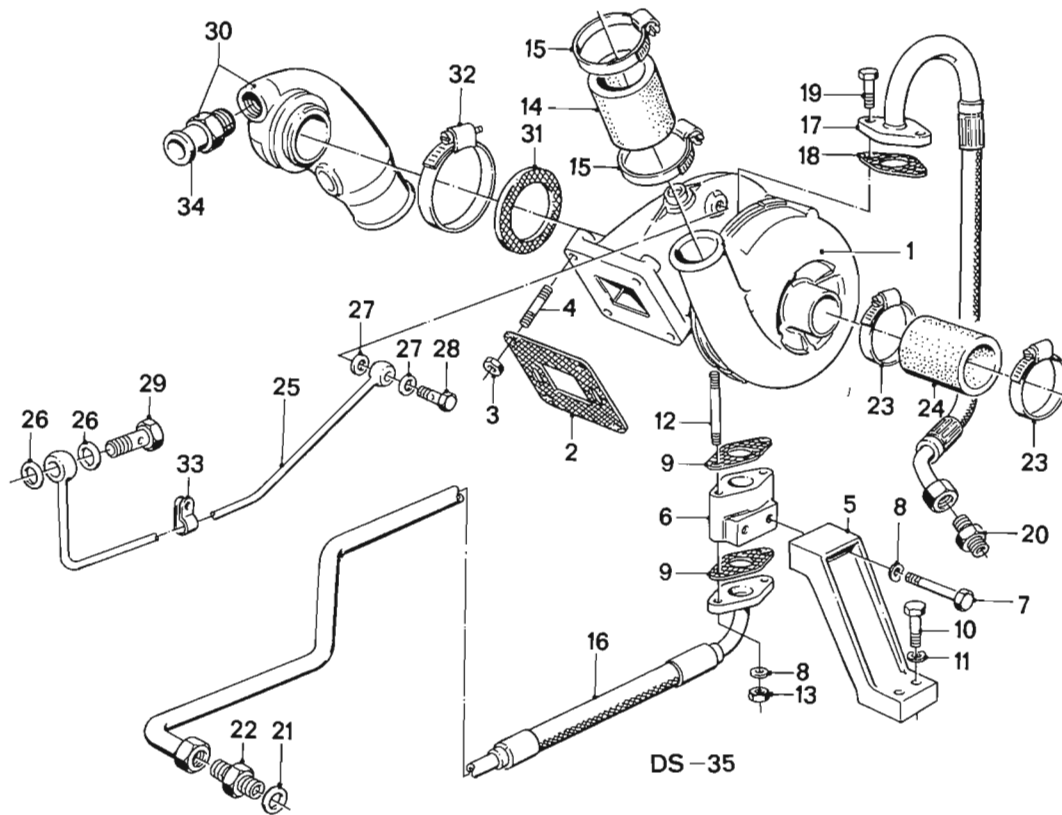

**11**  
**20/2**  
 D 530/636  
 4/86

11 20/2		4/86										
Nr.	Teile-Nummer	Symbol	Benennung	D 150	D 190	D 530	D 636	Bemerkung				
25	17 12 1 763 244		Entlüftungsleitung / Vent line / Conduite d'aération / Ventilationsledning / Tubo di disaerazione				1					
	17 12 1 763 723		dito			1						
26	07 11 9 963 130		A 12 DTRG			5	2					
27	07 11 9 963 072		A 6 DTRG			5	2					
28	17 12 1 763 353		A 6 Hohlschraube / Banjo bolt / Vis creuse / Hålskruv / Vite cava			1	1					
29	13 31 1 263 264		Doppelhohlschraube / Double banjo bolt / Vis creuse double / Dubbelhålskruv / Doppia vite cava			1	1					
30	18 11 1 763 206		kpl. Abgasrohr / Exhaust gas pipe / Tuyau d'échappement / Avgasrör / Tubo gas di scarico			1	1					
31	18 11 1 331 173		Dichtung / Seal / Garniture / Packning / Guarnizione			1	1					
32	18 11 1 763 273		Bolzenschelle / Bolt clip / Collier boulon / Bultklämma / Fascetta per bullone			1	1					
33	11 62 1 266 997		Rohrschelle / Pipe clamp / Bride de tuyau / Rörklämma / Fascetta di tubo				2					
34	17 11 1 761 273		Stutzen / Connection / Tubulure / Stuts / Bocchettone			1	1					
35	11 65 1 331 187	DS	Abgasturbine / Exhaust gas turbine / Turbine à gaz d'échappement / Avgasturbin / Turbina a gas di scarico	1		1	1	1				

V12 Engineering

www.bmwna.com

Abgasflanschrohr  
 Exhaust gas flange tube  
 Tube d'échappement à bride  
 Avgas-flänsrör  
 Tubo di scarico flangiato

BMW D 150 / D 190 / D 530 / D 636

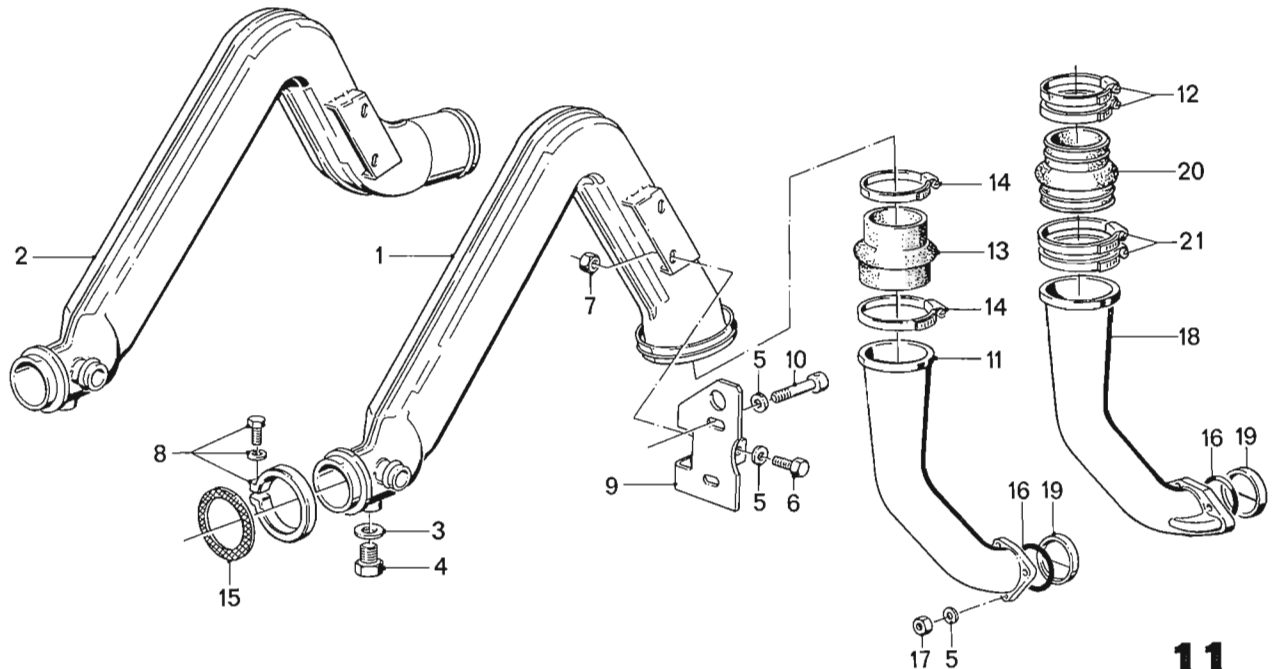

V12 Engineering

Box 50, Ontario, Canada P0X 1C0

[www.bmwmarine.net](http://www.bmwmarine.net)

11  
21

D 150/190/530/636  
4/86

11 21		4/86										
Nr.	Teile-Nummer	Symbol	Benennung	D 150	D 190	D 530	D 636					Bemerkung
1	18 111 761 385		Abgasendrohr / Exhaust gas end pipe / Embout d'échappement / Avgasändrör / Terminale di scarico	1	1							
2	a 18 111 761 384		dito	1	1							
3	07 119 963 200		A 14 DTRG	1	1							
4	18 111 333 485		VSL SHR M 14 x 1,5	1	1							
5	07 119 931 067		A 8,4 Scheibe / Washer / Ronelle / Bricka / Rondella	7	7	3	3					
6	07 119 913 624		6KT SHR M 8 x 16	2	2							
7	07 119 922 087		6KT MU M 8	2	2							
8	18 111 331 174		Schelle / Clamp / Collier / Klämme / Fascetta	1	1							
9	11 621 331 101		Stützwinkel / Support angle / Equerre-support / Vinkelstöd / Angolo di supporto	1	1							
10	07 119 919 978		ZYL SHR M 8 x 25	2	2							
11	d 11 621 326 429		Abgasflanschrohr / Exhaust gas flange tube / Tube d'échappement à bride / Avgas-flänsrör / Tubo di scarico flangiato	1	1							
	e 11 621 330 806		dito	1	1							
12	18 111 763 218		70-90 Schelle / Clamp / Collier / Klämme / Fascetta			2	2					
13	b 11 621 326 707		Verbindungsschlauch / Connecting hose / Flexible de raccordement / Slangförbindng / Tubo flessibile di collegamento	1	1							
	c 11 621 333 483		dito	1	1							
14	11 621 326 712		Ø 105 Schelle / Clamp / Collier / Klämme / Fascetta	2	2							
15	18 111 331 173		Dichtung / Seal / Garniture / Packning / Guarnizione	1	1							
16	11 621 326 508		O-Ring / O-ring / Joint torique / O-ring / Anello-O	1	1	1	1					
17	07 129 922 426		6KT MU M 8	3	3	3	3					
18	11 621 332 390		Abgasflanschrohr / Exhaust gas flange tube / Tube d'échappement à bride / Avgas-flänsrör / Tubo di scarico flangiato			1	1					
19	11 621 332 195		kpl. Rückschlagklappe / Non return flap / Clapet de retenue / Bagslagsklaff / Valvola di ritegno	1	1	1	1					
20	11 621 763 211		Verbindungsschlauch / Connecting hose / Flexible de raccordement / Slangförbindng / Tubo flessibile di collegamento				1					
21	18 111 763 219		90-110 Schelle / Clamp / Collier / Klämme / Fascetta			2	2					

a) Nur für Wendegetriebe / For reversing gearbox only / Uniquement pour réducteur-inverseur / Bara för backväxel / Solo per cambio ad inversione di marcia  
 b) → Aggr. Nr. 623 (D150) 6012 (D190)  
 c) Mot. Nr. → dito  
 d) → Z-Antrieb Nr. 7999 / → Stern drive Nr. 7999 / → Commande per engrénage Nr. 7999 / → Kugghjulsdriving Nr. 7999 / → Comando per ingranaggi Nr. 7999  
 e) Z-Antrieb Nr. → 8000 / Stern drive Nr. → 8000 / Commande per engrénage Nr. → 8000 / Kugghjulsdriving Nr. → 8000 / Comando per ingranaggi Nr. → 8000

V12 Engineering  
 www.bmwmarine.com



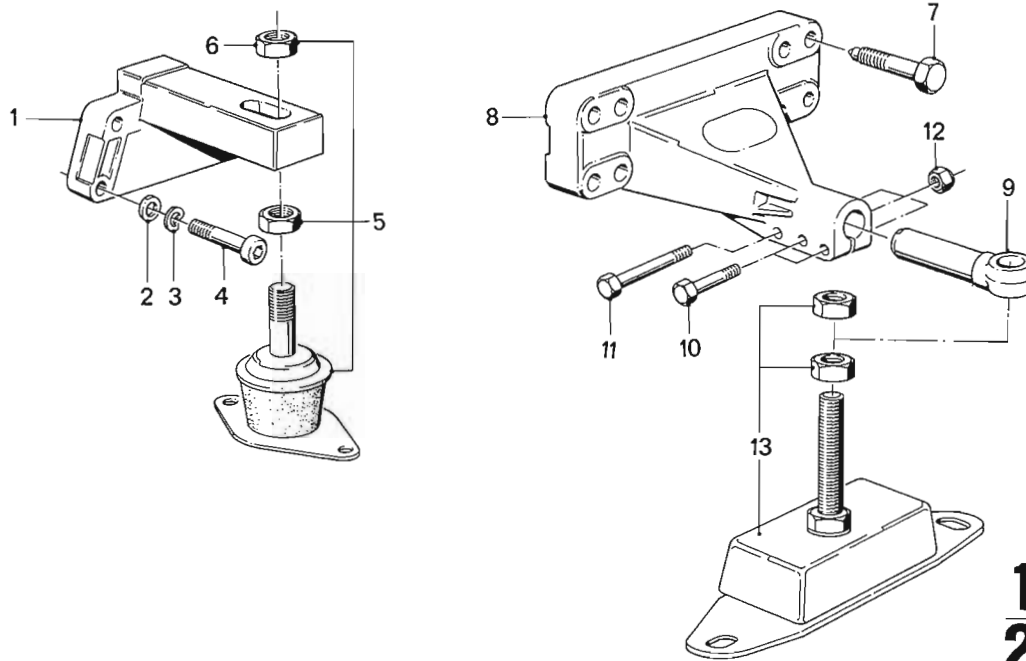

**11**  
**22**  
 D 150/190/530/636  
 4/86

11 22		4/86								
Nr.	Teile-Nummer	Symbol	Benennung	D 150	D 190	D 530	D 636	Bemerkung		
1	a 11 81 1 333 473		Motorpratze / Suspension bracket / Etrier de suspension / Fäste / Innesto a denti del motore	2	2					
2	07 11 9931 076		A 10,5 Scheibe / Washer / Rondelle / Bricka / Rondella	6	6					
3	07 11 9933 110		B 10 Federring / Spring lock washer / Rondelle élastique / Fjäderbricka / Anello elastico	6	6					
4	11 81 1 331 177	WW	ZYL SHR M 10 × 50	8	8					
	11 81 1 333 460	WW	ZYL SHR M 10 × 70	8	8					
5	11 81 1 761 146		Konuslager / Tapered bearing / Palier conique / Konsikt lager / Cuscinetto a rulli conici	2	2		2		HS 75	
6	07 11 9922 176		6 KT MU M 16 × 1,5	4	4	4	4			
7	07 11 9913 859		6 KT SHR M 10 × 50	7	7	7	8			
8	b 11 81 1 761 616		Motorpratze / Suspension bracket / Etrier de suspension / Fäste / Innesto a denti del motore	2	2	2	2			
9	11 81 1 333 894		Lagerbolzen / Fittingbolt / Boulon de palier / Lagerbult / Perno d'articolazione	2	2					
	11 81 1 763 304		dito				2			
10	11 81 1 761 617		SHR M 8 × 30	2	2	2	2			
11	07 11 9912 516		6 KT SHR M 8 × 50	4	4	4	4			
12	07 12 9922 426		6 KT MU	4	4	4	4			
13	c 11 81 1 763 916		Dachlager / Roof bearing / Palier de toit / Taklager / Supporto tetto			2	2		HS 65	
	d 11 81 1 763 917		dito			2	2		HS 55	

a) → Aggr. Nr. 653 (D150) 6039 (D190)

b) Aggr. Nr. → dito

c) n. f. Wende-Bobtail-Jetmotor / Reversing bobtail jet motor / Moteur de renversement de marche Bobtail / Wende-Bobtail-Jetmotor /  
Motore-jet-bobtail ad inversione

d) n. f. Z-Antriebmotor / Z drive engine / Moteur d'entraînement Z / Z-Startmotor / Motore di propulsione Z

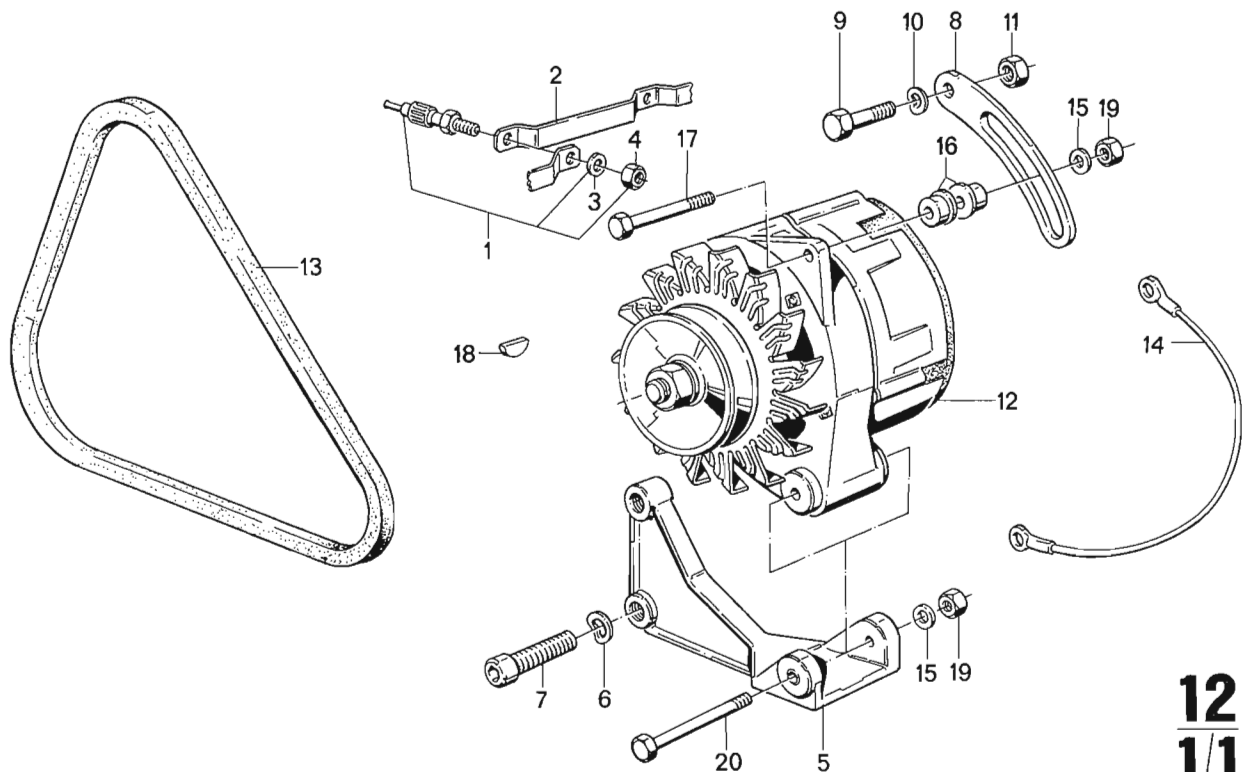

**12**  
**1/1**

D 150/190/530/636  
4/86

<b>12</b> <b>1/1</b>		4/86										
Nr.	Teile-Nummer	Symbol	Benennung	D 150	D 190	D 530	D 636	Bemerkung				
1	12 12 1 331 939		11 V Glühstiftkerzen / Sheated-element (pencil type) glow plug / Bougies de préchauffage / Glödändstift / Candela ad incandescenza a bulbo	6	6							
	12 12 1 763 464		12 V dito			5	6					
2	12 12 1 331 940		Verbindungsbrücke / Connecting bridge / Pont de raccordement / Förbindningsbrygga / Pezzo d'unione	5	5	3	5					
3	07 11 9932 047		B5 Federscheibe / Spring washer / Rondelle élastique / Fjäderbricka / Rosetta elastica	6	6	5	6					
4	07 11 9921 038		6KT MU M 5	6	6	5	6					
5	12 31 1 333 477		Lagerbock / Support / Support de palier / Lagerbock / Supporto del cuscinetto	1	1							
	12 31 1 763 465		dito			1	1					
6	07 11 9931 088		A 15 Federscheibe / Spring washer / Rondelle élastique / Fjäderbricka / Rosetta elastica	2	2	2	2					
7	12 31 1 333 479		6KT SHR M 14 × 50	2	2	2	2					
8	12 31 1 333 480		Spannlasche / Tightening clip / Eclisse de réglage / Spännlask / Biscottino di tensione	1	1							
9	07 11 9913 834		6KT SHR M 10 × 25	1	1							
10	07 11 9931 076		B 10 Federring / Spring lock washer / Rondelle élastique / Fjäderbricka / Rosetta elastica	1	1							
11	07 11 9922 113		6KT MU M 10	1	1							
12	12 31 1 333 943		kpl. 14 V 75 A Generator / Generator / Générateur / Generator / Generatore	1	1		1				Motorola	
	12 31 1 334 335		kpl. dito				1	1			Motorola	
13	a 12 31 1 333 934		9,5 × 1025 Keilriemen / V-belt / Courroie trapézoidale / Kilrem / Cinghia trapezoidale	1	1							
	b 12 31 1 761 690		9,5 × 1050 dito	1	1							
	12 31 1 761 869		12,5 × 1065			1	1					
14	12 51 1 333 979		Massekabel / Ground lead / Câblé de masse / Jordledningskabel / Cavo di massa	1	1							
15	07 11 9931 067		A 8,4 Scheibe / Washer / Rondelle / Bricka / Rondella	2	2	1	1					

a) → Aggr. Nr. 653 (D150) → 6039 (D190)

b) Aggr. Nr. → dito

Generator – Motorola  
 Generator – Motorola  
 Générateur – Motorola  
 Generator – Motorola  
 Generatore – Motorola

BMW D 150 / D 190 / D 530 / D 636

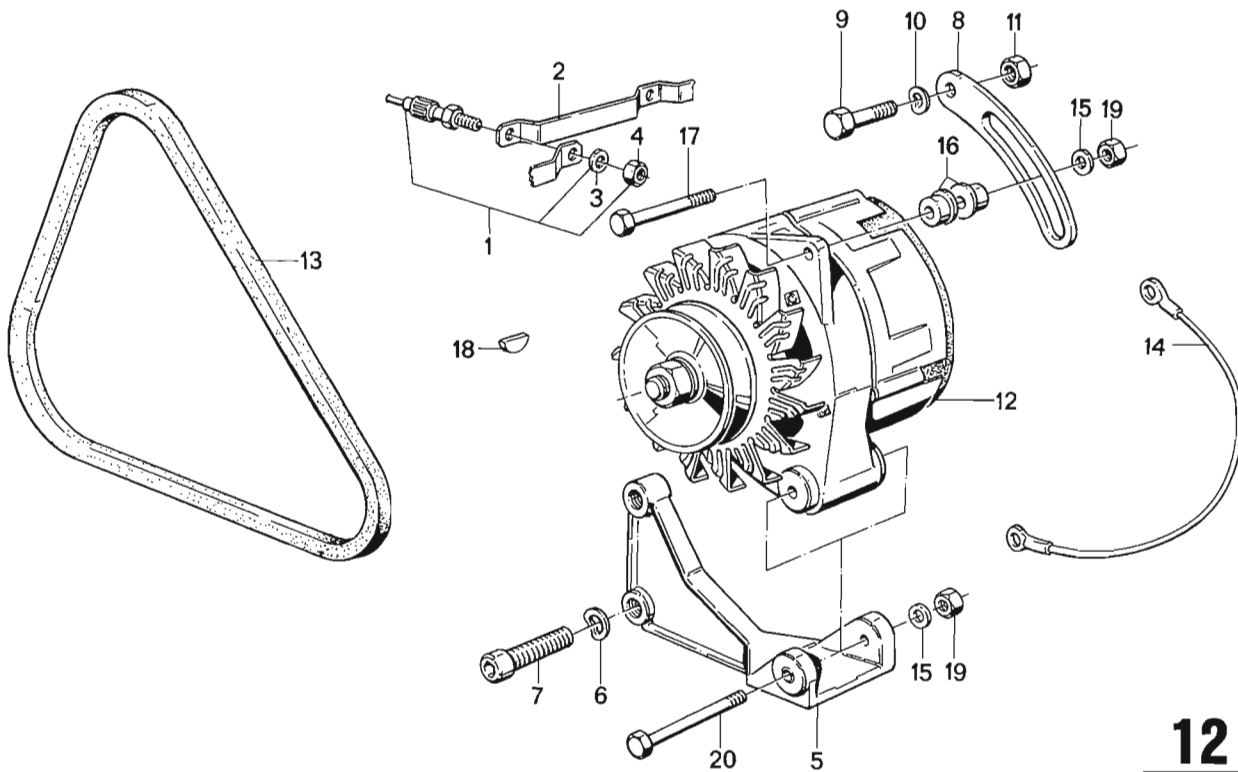

**12**  
**1/2**

D 150/190/530/636  
4/86

<b>12</b> <b>1/2</b>		4/86										
Nr.	Teile-Nummer	Symbol	Benennung	D 150	D 190	D 530	D 636	Bemerkung				
16	12 311 329 282		Distanzbüchse / Spacer socket / Douille d'écartement / Distanshylsa / Boccola distanziatore	2	2							
17	07 119 912 506		6 KT SHR M 8 × 45	1	1							
18	07 119 951 453		Scheibfeder / Disk spring / Ressort en rondelle / Planfjäder / Molla per disco	1	1	1	1					
19	07 119 922 426		6 KT MU M 8	2	2	1	1					
20	07 119 912 562		6 KT SHR M 8 × 85	1	1							
	07 119 912 567		6 KT SHR M 8 × 90			1	1					

a) → Aggr. Nr. 653 (D150) → 6039 (D190)  
 b) Aggr. Nr. → dito

V12 Engineering

www.bmwmarine.com

Generator – Motorola  
 Generator – Motorola  
 Générateur – Motorola  
 Generator – Motorola  
 Generatore – Motorola

BMW D 150 / D 190 / D 530 / D 636

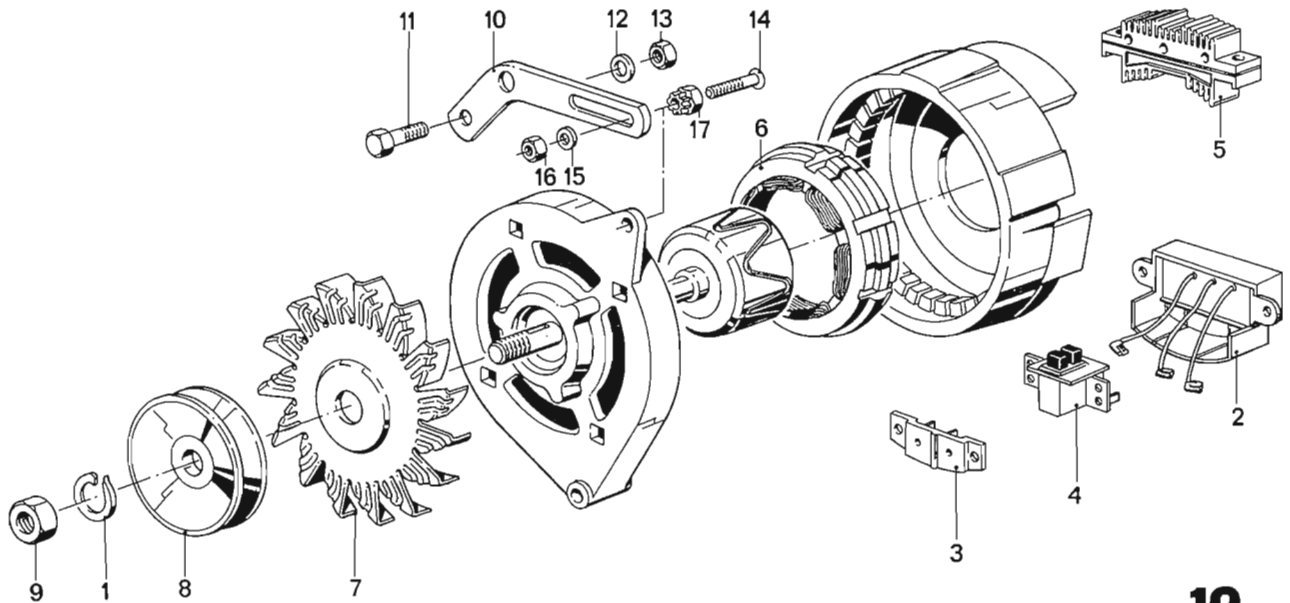

**12**  
**2**

D 150/190/530/636  
4/86

		12/2											
		4/86											
Nr.	Teile-Nummer	Symbol	Benennung	D 150	D 190	D 530	D 636	Bemerkung					
1	07 119933 149		B 14 Federscheibe / Spring washer / Rondelle élastique / Fjäderbricka / Rosetta elastica	1	1	1	1						
2	12 31 1333 937		Regler / Regulator / Régulateur / Régulateur / Regulatore	1	1	1	1						
3	12 31 1334 010		Relaisplatte / Relay plate / Plaque de relais / Reläplatta / Base di relè	1	1	1	1						
4	12 31 1334 011		Kohlenhalter / Carbon holder / Support de charbon / Kolhållare / Portacarboncini	1	1	1	1						
5	12 31 1334 012		Diodeplatte / Diodeplate / Porte-diodes / Diodplatta / Placca di diodi	1	1	1	1						
6	12 31 1334 013		Ständer / Stator / Stator / Stator / Statore	1	1	1	1						
7	12 31 1333 944		Lüfter / Fan / Ventilateur / Ventilator / Ventilatore	1	1	1	1						
8	12 31 1333 939		Riemenscheibe / Pulley / Pouille / Remskiva / Puleggia	1	1	1	1						
9	07 119921 631		6KT MU M 14 x 1,5	1	1	1	1						
10	12 31 1763 365		Spannbügel / Clamp clip / Etrier de serrage / Spännbygel / Staffa tenditrice				1						
11	07 119913 834		6 KT SHR M 10 x 25				1						
12	07 119931 076		A 10,5 Scheibe / Washer / Rondelle / Bricka / Rondella				1						
13	07 119922 113		6KT MU M 10				1						
14	12 31 1276 540		M 8 x 50 Flachrandschraube / Screw / Vis / Skruv / Vite a testa rotondapiatta				1						
15	07 119931 067		A 8,4 Scheibe / Washer / Rondelle / Bricka / Rondella				1						
16	07 119922 714		6KT MU M 8				1						
17	12 31 1273 639		Spannritzel / Clamp pinion / Pignon de serrage / Spännhjul / Pignone tenditore				1						

V12 Engineering  
 www.bmwmarine.com

Anlasser  
 Starter  
 Démarreur  
 Startmotor  
 Motorino d'avviamento

BMW D 150 / D 190 / D 530 / D 636

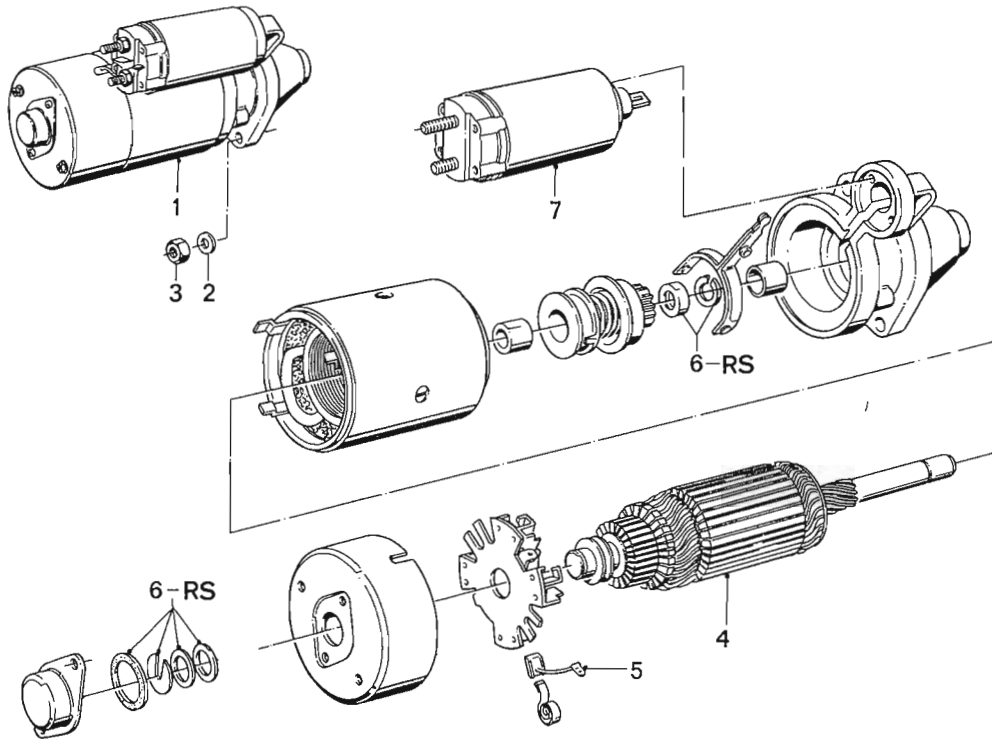

**12**  
**3**

D 150/190/530/636  
4/86

<b>12</b> <b>3</b>		4/86									
Nr.	Teile-Nummer	Symbol	Benennung	D 150	D 190	D 530	D 636	Bemerkung			
1	12 411 333 980		12 V / 2,7 kW Anlasser / Starter / Démarreur / Startmotor / Motorino d'avviamento	1	1	1	1				
2	07 119 932 132		B 12 Federscheibe / Spring washer / Rondelle élastique / Fjäderbricka / Rosetta elastica	2	2	2	2				
3	07 119 922 133		6 KT MUM 12	2	2	2	2				
4	12 411 334 377		Anker / Armature / Inducteur / Ankare / Indotto	1	1	1	1				
5	12 411 334 378		Kohlebürstensatz / Brush set / Jeu de balais de charbon / Sats kolborstar / Corredo spazz. carbone	1	1	1	1				
6	12 411 334 379	RS	Teilesatz-Anker / Parts set armature / Jeu de pieces inducteur / Delsats ankare / Corredo di pezzi di indotto	1	1	1	1				
7	12 411 334 380		Einrückrelais / Engaging relay / Relais d'engagement / Inryckningsrelä / Relais d'innesto	1	1	1	1				

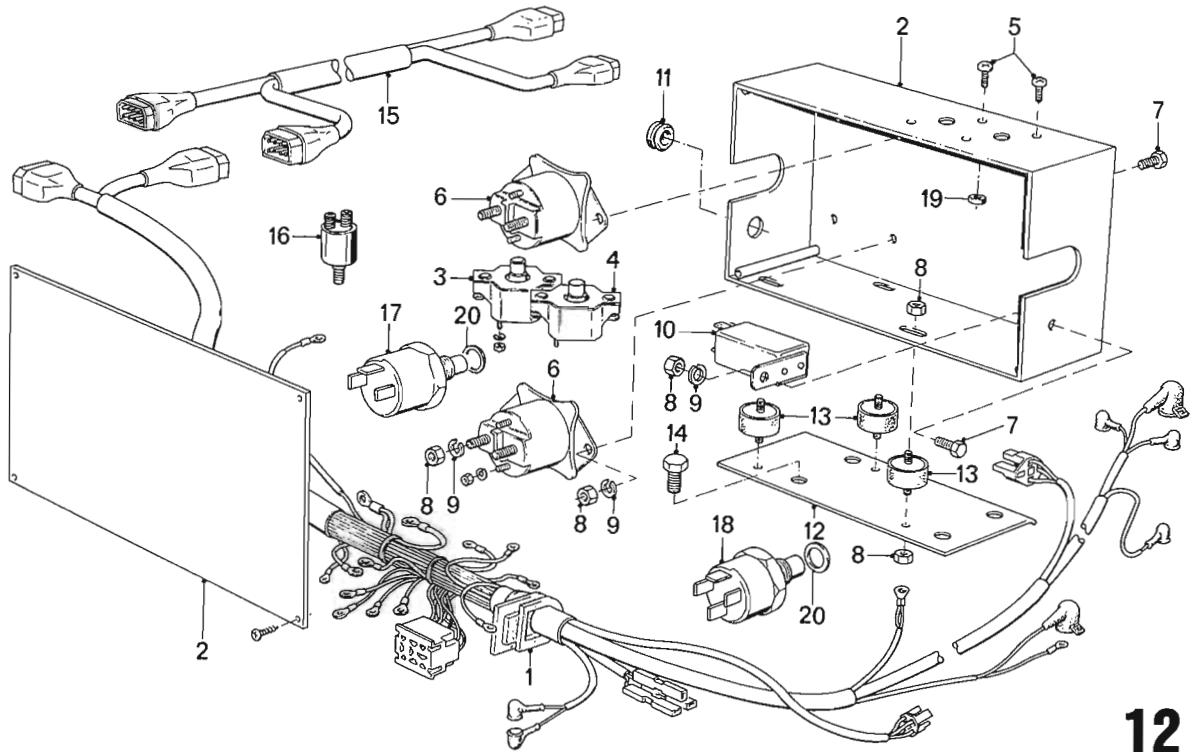

**12**  
**4/1**  
 D 150/190  
 4/86

<b>12</b> <b>4/1</b>		4/86									
Nr.	Teile-Nummer	Symbol	Benennung	D 150	D 190	D 530	D 636	Bemerkung			
1	1251 1331 976		Kabelbaum-Motor / Cable harness-motor / Harnais de câbles-moteur / Kabelbom-motor / Fascio de cavi motore	1							
2	1252 1331 942		Elektrobox / Electrobox / Boîtier électrique / Elektrobox / Box elettrica	1							
3	61 131 329 978		60 A Sicherungsautomat / Automatic fuse / Coupet-circuit automatique / Automatsäkring / Autom. di sicurezza	1	1	2	2				
4	61 131 329 977		40 A dito	1	1						
5	07 11 9907 633		LIN SHR	4	4						
6	27 64 1 326 546		Magnetschalter / Magnetic switch / Commutateur à relais / Magnetbrytare / Interruttore magnet	2	2	2	2				
7	07 11 9913 442		6 KT SHR M 6 x 12	5	5						
8	07 12 9922 058		6 KT MU M 6	11	11						
9	07 11 9931 044		Scheibe / Washer / Rondelle / Bricka / Rondella	8	8						
10	12 63 1 329 960		Glühzeitautomatikrelais / Automatic glow period relay / Relais pour commande automatique de temps de préchauffage / Automat relä glödningsstid / Relè per il comando automatico del tempo di incandescenza	1	1						
11	46 63 1 233 200		Gummitülle / Rubber grommet / Douille en caoutch. / Gummihatt / Boccia di gomma	1	1						
12	12 52 1 333 922		Halteblech / Fixing plate / Plaque de support / Plåthållare / Lamiera di sostegno	1	1						
13	13 71 1 259 818		Lagerungsgummi / Bearing rubber / Caoutchouc pour support / Gummilagring / Gomma di supporto	3	3						
14	07 11 9913 815		6 KT SHR M 10 x 16	2	3						
15	a 1251 1331 978		6 m Kabelbaum / Cable harness / Harnais de cables / Kabel bom / Fascio di cavi	1	1		1				
16	12 61 1 331 979		Öldruckgeber / Oil pressure transmitter / Transmetteur de pression d'huile / Oljetryckgivare / Trasmittitore di segnalazione pressione olio	1	1	1	1				
17	12 61 1 329 961		Öltemperaturgeber / Oil temperature transmitter / Transmetteur de température d'huile / Oljtemperaturgivare / Trasmittitore temperatura dell'olio	1	1	1	1				

a) für IDEA + VDO Instrumententafel  
 for IDEA + VDO instrument panel  
 pour IDEA + VDO tableau des instruments  
 för IDEA + VDO instrumenttavla  
 per IDEA + VDO cruscotto

V12 Engineering  
 www.bmwmarine.com

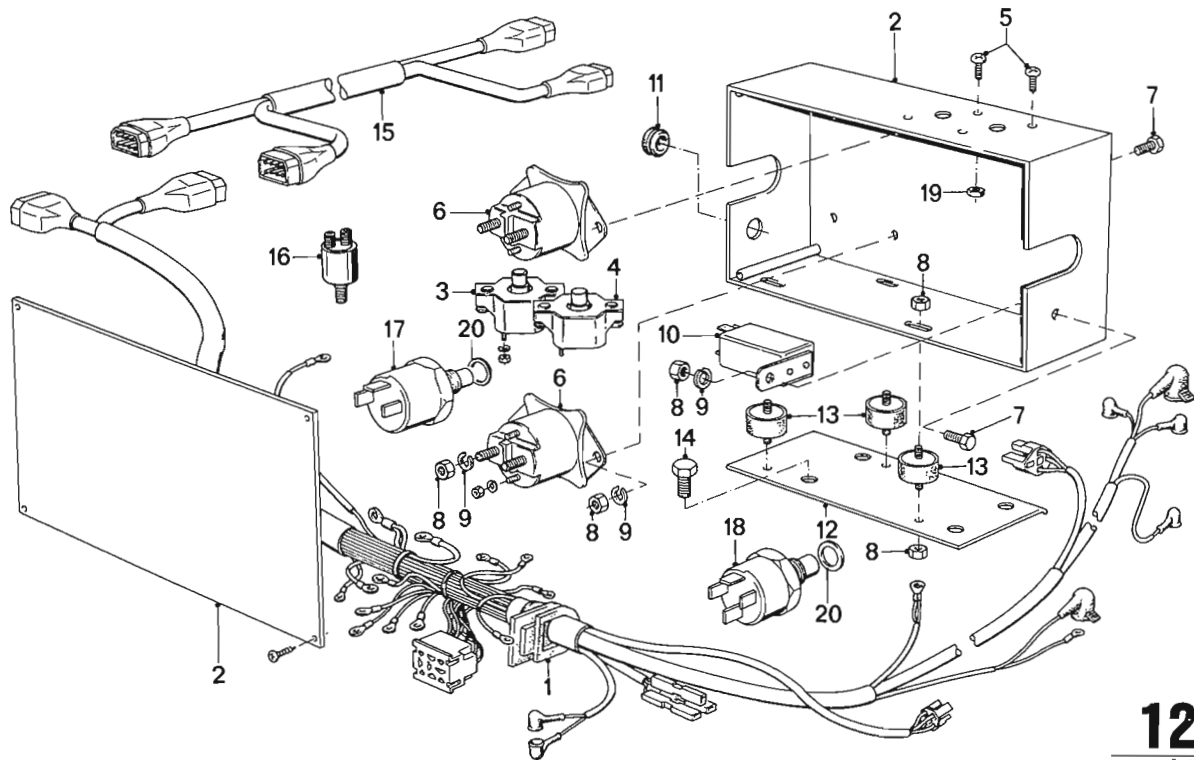

**12**  
**4/2**  
 D 150/190  
 4/86

<b>12</b> <b>4/2</b>		4/86									
Nr.	Teile-Nummer	Symbol	Benennung	D 150	D 190	D 530	D 636	Bemerkung			
18	12 61 1 333 996		Wassertemperaturgeber / Water temperature transmitter / Transmetteur de température d'eau / Vattentemperaturgivare / Trasmittitore di temperatura dell'acqua	1	1	1	1				
19	07 119 922 038		6 KT MU M 5 x 8 DTRG	4	4						
20	07 119 963 201			2	2	2	2				

a) für IDEA + VDO Instrumententafel  
 for IDEA + VDO instrument panel  
 pour IDEA + VDO tableau des instruments  
 för IDEA + VDO instrumenttavla  
 per IDEA + VDO cruscotto

V12 Engineering  
 www.bmwmarine.com

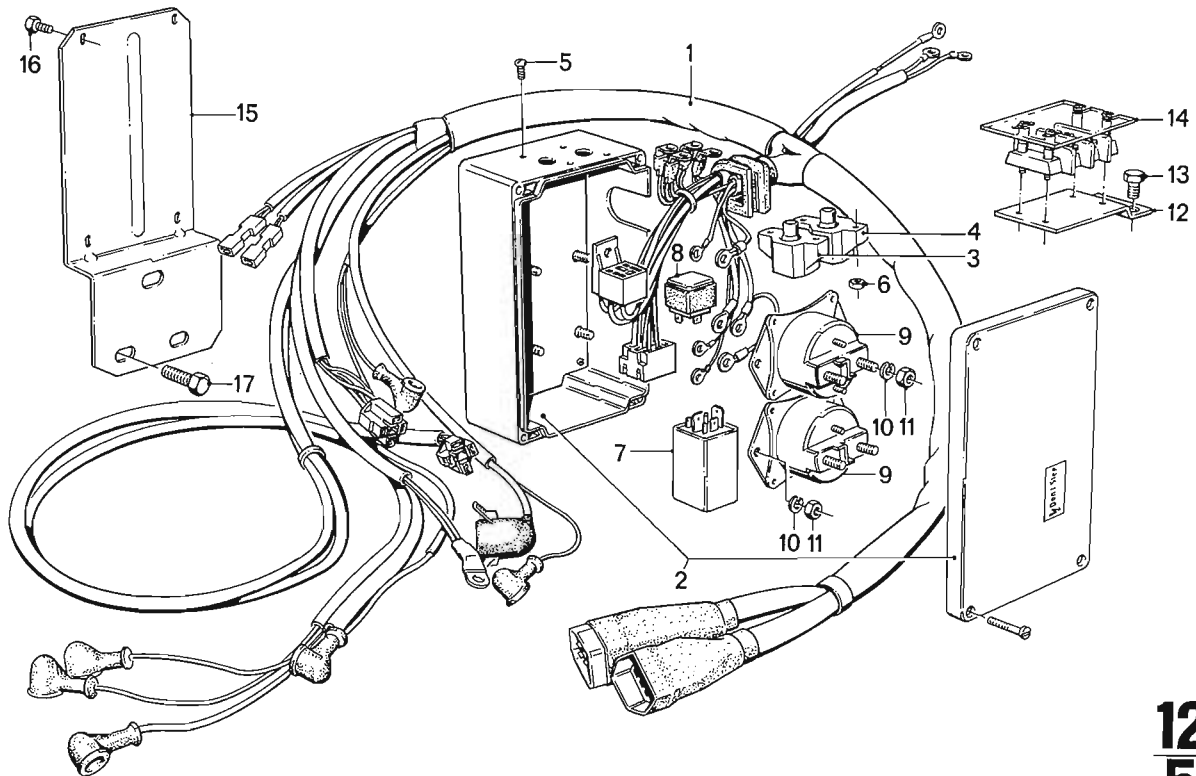

**12**  
**5**

D 150/D 190  
4/86

12 5		4/86									
Nr.	Teile-Nummer	Symbol	Benennung				D 150	D 190	D 530	D 636	Bemerkung
1	a 12511334057		Kabelbaum-Motor / Cable harness-motor / Harnais de câbles-moteur / Kabelbom-motor / Fascio de cavi motore				1	1			IDEA
	b 12511334070		dito				1	1			IDEA
	c 12521334181		dito				1	1			VDO
	d 12521334183		dito				1	1			VDO
2	12511334058		Elektrobox / Electrobox / Boitier électrique / Elektrobox / Box elettrica				1	1			
3	61131329978		60 A Sicherungsautomat / Automatic fuse / Coupet-circuit automatique / Automatsäkring / Autom. di sicurezza				1	1	2	2	
4	61131329977		40 A dito				1	1			
5	07119907633		LIN SHR M 5 x 12				4	4			
6	07119922038		6 KT MU M 5				4	4			
7	12631329960		Glühzeitautomatrelais / Automatic glow period relay / Relais pour commande automatique de temps de préchauffage / Automat relä glödningsid / Rele per il comando automatico del tempo di incandescenza				1	1			
8	61311373586		Kleinrelais / Minirelay / Relais miniature / Litet relä / Minirelais				1	1			
9	a 27641326546		Magnetstartschalter / Solenoid switch / Commutateur de magnéto / Solenoidkontakt / Commutatore elettromagnetico				2	2	2	2	
10	07119931044		Scheibe / Washer / Rondelle / Bricka / Rondella				4	4	4	4	
11	07129922058		6 KT MU M 6				4	4			
12	a 12511334051		Halter / Support / Support / Fäste / Sostegno				1	1	1	1	
13	a 07119913815		6 KT SHR M 10 x 16				2	2	2	2	
14	a 12511334064		kpl. Klemmleiste / Terminal strip / Réglette de bornes / Klämlist / Listello di raccordo				1	1	1	1	
15	12511334050		Halter / Support / Support / Fäste / Sostegno				1	1			
16	07119907688		LIN SHR M 4 x 12				4	4		4	
17	07119913815		6 KT SHR M 10 x 16				3	3			

V12 Engineering  
 Box 50, Ontario, Canada POX 1C0  
 www.bmwmarine.net

a) Nur für Z-Antrieb / For gear drive only / Uniquement pour Commande per engranage / Bara för Kuggghjulsdrivning / Solo per comando per ingranaggi  
 b) Nur für Wendegetriebe / For reversing gearbox only / Uniquement pour réducteur-inverseur / Bara för backväxel / Solo per cambio ad inversione di marcia  
 c) Aggr. Nr. → 6644 (D 190) Nur für Z-Antrieb / For gear drive only / Uniquement pour Commande per engranage / Bara för Kuggghjulsdrivning / Solo per comando per ingranaggi  
 d) Aggr. Nr. → 863 (D 150) 6619 (D 190) Nur für Wendegetriebe / For reversing gearbox only / Uniquement pour réducteur-inverseur / Bara för backväxel / Solo per cambio ad inversione di marcia

V12 Engineering  
 www.bmwmarine.com



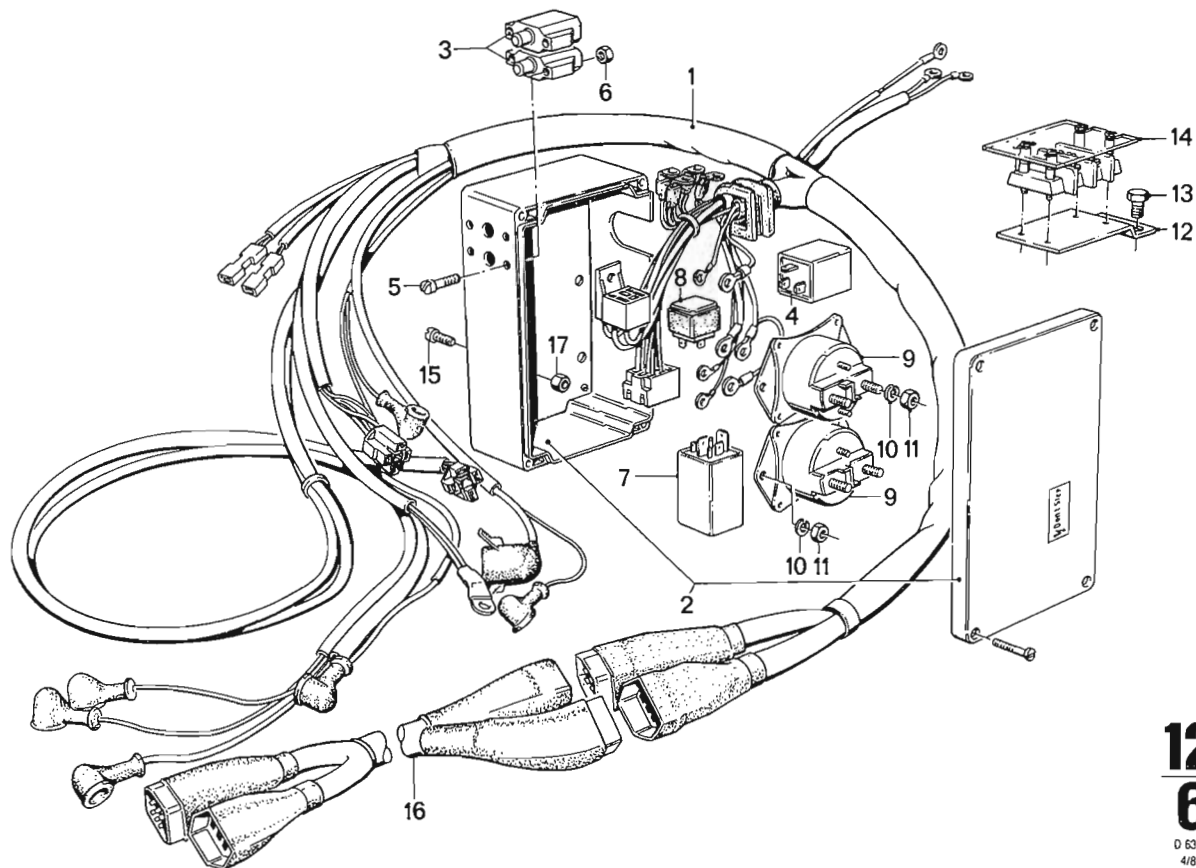

**12**  
**6**  
D 636  
4/86

12 6		4/86											
Nr.	Teile-Nummer	Symbol	Benennung	D 150	D 190	D 530	D 636	Bemerkung					
1	a 1251 1 334 302		Kabelbaum-Motor / Cable harness-motor / Harnais de câbles-moteur / Kabelbom-motor / Fascio de cavi motore				1						
	b 1251 1 334 310		dito										
2	1251 1 334 305		Elektrobox / Electrobox / Boitier électrique / Elektrobox / Box elettrica				1	1	2	2			
3	61 13 1 329 978		60 A Sicherungsautomat / Automatic fuse / Coupet-circuit automatique / Automatsäkring / Autom. di sicurezza	1									
4	12 63 1 334 392		Leistungsrelais / Power relay / Relais de puissance / Effektrelä / Relais di potenza				3	1					
5	07 11 9 907 583		LIN SHR M 4 x 20				4	4					
6	07 11 9 922 028		6 KT MU M 4				4	4					
7	12 63 1 334 306		Vorglührelais / Preheating relay / Relais de préchauffe / Förglödrelä / Relais di preriscaldamento				1	1					
8	61 31 1 334 372		Kleinrelais / Minirelay / Relais miniature / Litet relä / Mini-relais				1	1					
9	a 27 64 1 326 546		Magnetstaatschalter / Solenoid switch / Commutateur de magnéto / Solenoidkontakt / Commutatore elettromagnetico				2	2					
10	07 11 9 931 044		Scheibe / Washer / Rondelle / Bricka / Rondella	4	4	4	4						
11	07 12 9 922 058		6 KT MU M 6	4	4	4	4						
12	a 12 51 1 334 051		Halter / Support / Support / Fäste / Sostegno	1	1	1	1						
13	a 07 11 9 913 815		6 KT SHR M 10 x 16	2	2	2	2						
14	a 12 51 1 334 064		kpl. Klemmleiste / Terminal strip / Reglette de bornes / Klämmlist / Listello di raccordo	1	1	1	1						
15	07 11 9 907 688		LIN SHR M 4 x 12	4	4	4	4						
16	12 51 1 331 978		6 m Kabelbaum / Cable harness / Faisceau de câble / Kabelbom / Fascio di cavi	1	1	1	1						
17	07 12 9 922 403		6 KT MU M 4				4	4					

a) Nur für Z-Antrieb / For gear drive only / Uniquement pour Commande per engrènement / Bara för Kugghjulsdrevning / Solo per comando per ingranaggi  
 b) Nur für Wendegetriebe Jet-Bottail / For reversing gearbox Jet-Bottail only / Uniquement pour réducteur-inverseur Jet-Bottail / Bara för backväxel Jet-Bottail / Solo per cambio ad inversione di marcia Jet-Bottail

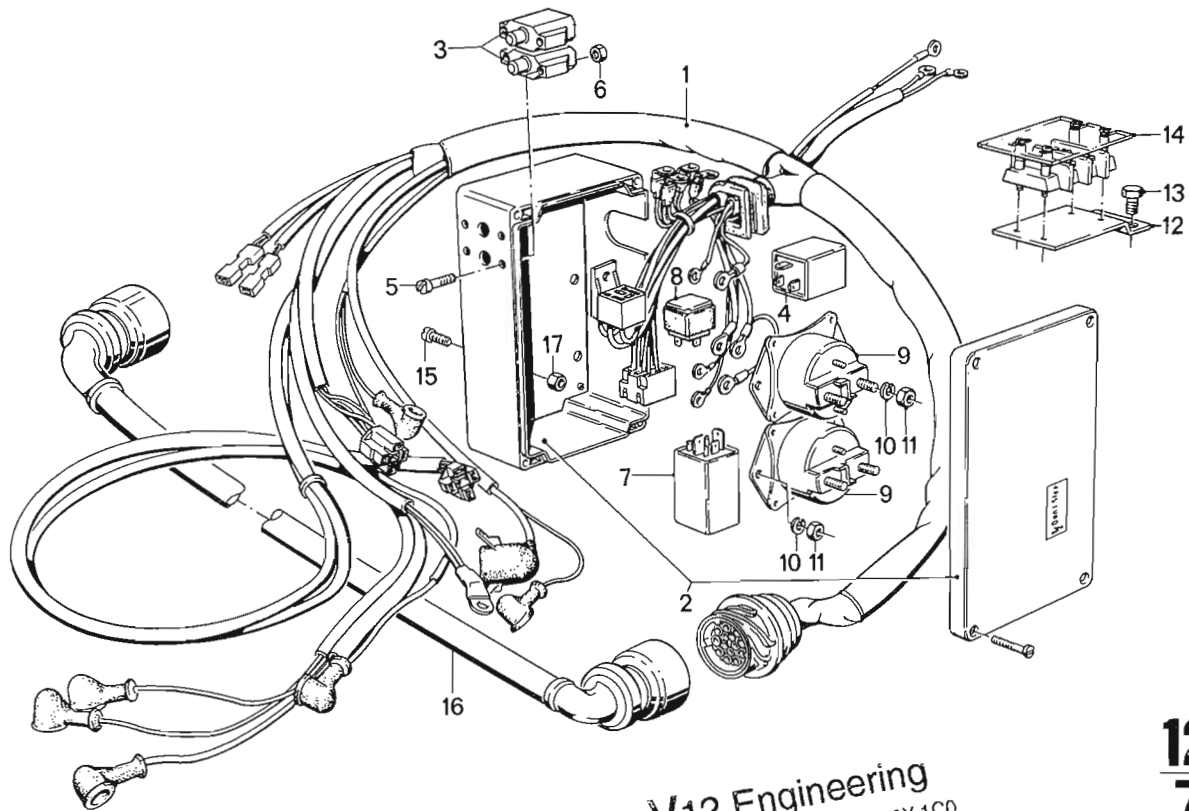

V12 Engineering  
 Box 50, Ontario, Canada POX 1C0  
 www.bmwmarine.net

12  
7

D 150/190/530/636  
4/86

12 7		4/86											
Nr.	Teile-Nummer	Symbol	Benennung	D 150	D 190	D 530	D 636	Bemerkung					
1	a 1251 1764 012		Kabelbaum-Motor / Cable harness-motor / Harnais de câbles-moteur / Kabelbom-motor / Fascio de cavi motore				1						
	b 1251 1764 011		dito				1						
2	1251 1334 495		Elektrobox / Electrobox / Boîtier électrique / Elektrobox / Box elettrica				1						
3	61 13 1329 978		60 A Sicherungsautomat / Automatic fuse / Coupet-circuit automatique / Automatsäkring / Autom. di sicurezza	1	1	2	2						
4	1263 1334 392		Leistungsrelais / Power relay / Relais de puissance / Effektrele / Relais di potenza				3	1					
5	07 119907 583		LIN SHR M 4 x 20				4	4					
6	07 119922 028		6 KT MU M 4				4	4					
7	1263 1334 306		Vorglührelais / Preheating relay / Relais de préchauffe / Förglödrelä / Relais di preriscaldamento				1	1					
8	61 31 1334 372		Starterrelais / Starting relay / Relais de démarreur / Startrelä / Relè di avviamento				2	2					
9	a 2764 1326 546		Magnetstartschalter / Solenoid switch / Commutateur de magnéto / Solenoidkontakt / Commutatore elettromagnetico				2	2					
10	07 119931 044		Scheibe / Washer / Rondelle / Bricka / Rondella	4	4	4	4						
11	07 129922 058		6 KT MU M 6	4	4	4	4						
12	a 1251 1334 051		Halter / Support / Support / Fäste / Sostegno	1	1	1	1						
13	a 07 119913 815		6 KT SHR M 10 x 16	2	2	2	2						
14	a 1251 1334 064		kpl. Klemmleiste / Terminal strip / Reglette de bornes / Klämlist / Listello di raccordo	1	1	1	1						
15	07 119907 688		LIN SHR M 4 x 12	4	4	4	4						
16	1251 1764 115		6 m Kabelbaum / Cable harness / Faisceau de câble / Kabelbom / Fascio di cavi				1						
17	07 129922 403		6 KT MU M 4				4	4					

a) Nur für Z-Antrieb / For gear drive only / Uniquement pour commande per engragge / Bara för kugghjulsdrivning / Solo per comando per ingranaggi  
 b) Nur für Wendegetriebe Jet-Bobtail / For reversing gearbox Jet-Bobtail only / Uniquement pour réducteur-inverseur Jet-Bobtail / Bara för backväxel Jet-Bobtail / Solo per cambio ad inversione di marcia Jet-Bottail

V12 Engineering  
 www.bmwmarine.com



Kraftstofffilter  
 Fuel filter  
 Filtre à carburant  
 Bränslefilter  
 Filtro carburante

BMW D 150 / D 190 / D 530 / D 636

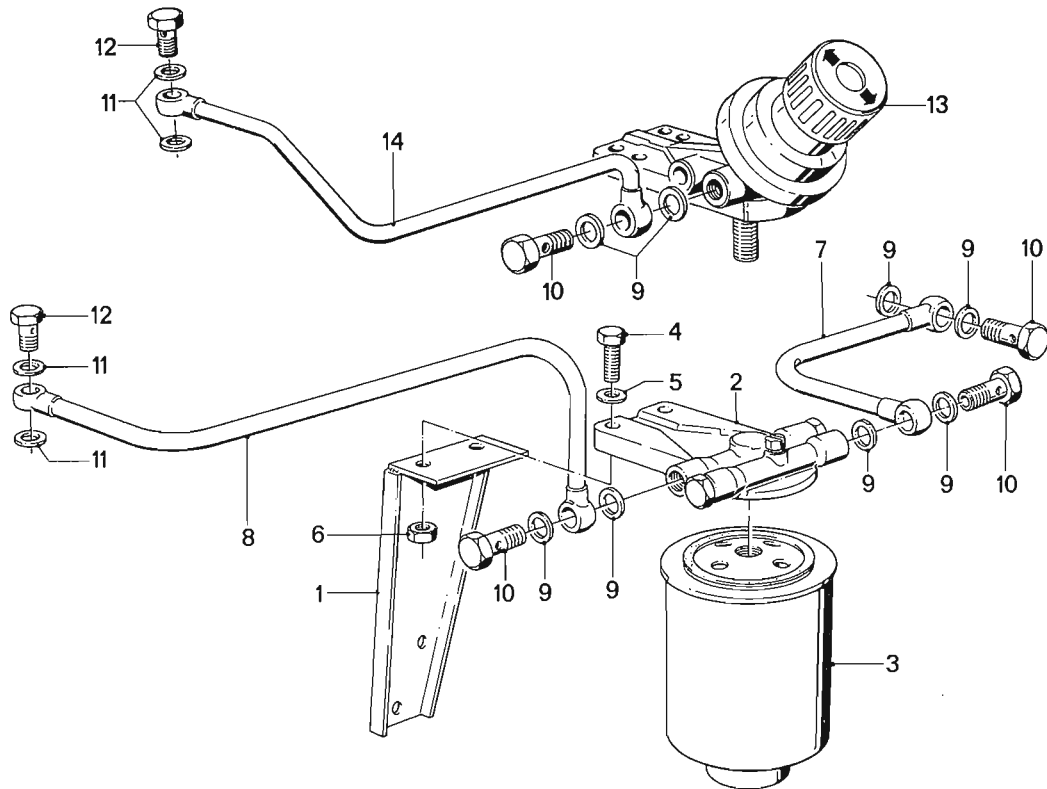

**13**  
**1**

D 150/190/530/636  
4/86

13 1		4/86							
Nr.	Teile-Nummer	Symbol	Benennung	D 150	D 190	D 530	D 636	Bemerkung	
1	a 1332 1761 553		Haltewinkel / Support angle / Corniere d'appui / Winkelstöd / Squadra di sostegno	1	1				
	1332 1763 598		dito			1	1		
2	a 1332 1761 372		Filterkopf / Filter head / Tête de filtre / Filterhuvud / Testata del filtro	1	1				
3	a 1332 1761 373		Filterpatrone / Filter cartridge / Cartouche de filtre / Filterpatron / Elemento filtrante	1	1	1	1		
4	07 11 9913 843		6 KT SHR M 10 x 35	2	2	2	2		
5	07 11 9931 076		B 10,5 Scheibe / Washer / Rondelle / Bricka / Rondella	2	2	2	2		
6	07 11 9922 113		6 KT MU M 10	2	2	2	2		
7	a 1331 1761 554		Kraftstoffleitung / Fuel pipnig / Tuyau de carburant / Bränsleledning / Conduittura carburante	1	1		1		
	1331 1763 809		dito				1		
8	a 1331 1761 555		dito	1	1				
9	07 11 9963 201		DTRG	6	6	6	6		
10	3241 1117 181		Hohlschraube / Banjo bolt / Vis creuse / Hålskruv / Vite cava	3	3	3	3		
11	07 11 9963 129		DTRG	2	2	2	2		
12	1612 1119 240		Hohlschraube / Banjo bolt / Vis creuse / Hålskruv / Vite cava	1	1	1	1		
13	1332 1763 271		Kraftstofffilterkopf – Handpumpe / Fuel filter head hand primer / Pompe à main tête filtre de carburant / Bränslefilterhuvud – handpump / Testata filtro del carburante – pompa a mano				1	1	
14	1331 1763 210		Kraftstoffleitung / Fuel piping / Tuyau de carburant / Bränsleledning / Conduittura carburante				1	1	

V12 Engineering  
 Box 50, Ontario, Canada POX 1C0  
 www.bmwmarine.net

a) Mot. Nr. → 653 (D150) → 6039 (D190)

V12 Engineering  
 www.bmwmarine.com

Kraftstoffpumpe, Kraftstofffilter  
 Fuel pump, Fuel filter  
 Pompe à carburant, Filtre à carburant  
 Bränslepump, Bränslefilter  
 Pompa alimentazione, Filtro carburante

BMW D 150 / D 190 / D 530 / D 636

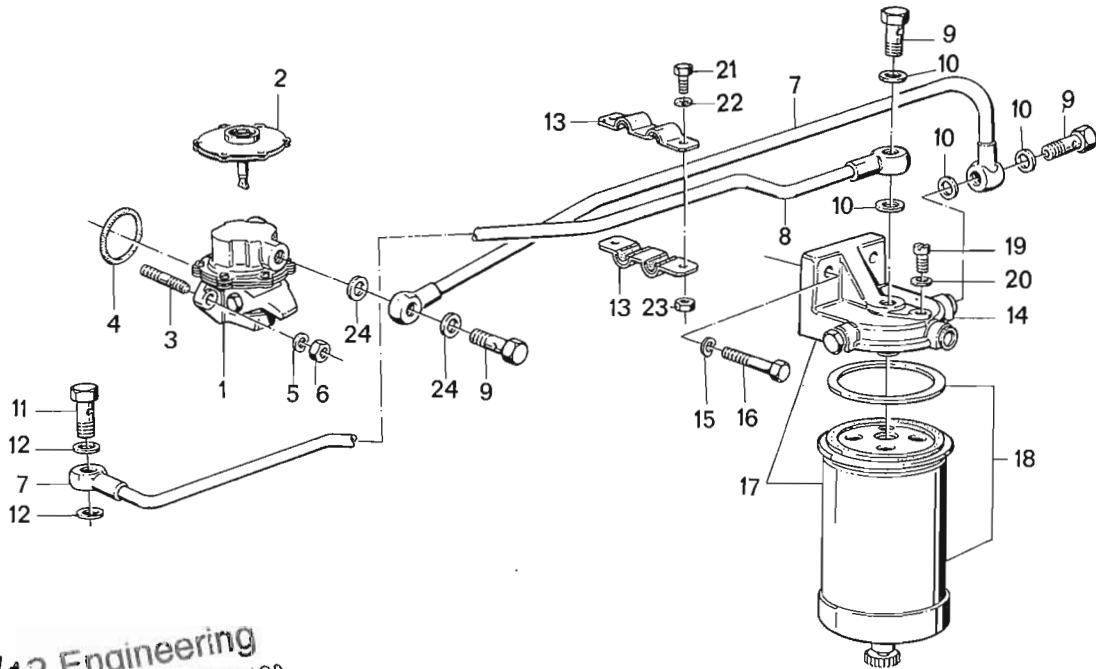

V12 Engineering  
 Box 50, Ontario, Canada POX 1C0  
[www.bmwmarine.net](http://www.bmwmarine.net)

**13**  
**2**  
D 150/D 190  
4/86

						D150	D190	D530	D636		
Nr.	Teile-Nummer	Symbol	Benennung				Bemerkung				
1	1331 1331 218		kpl. Kraftstoffpumpe / Fuel pump / Pompe à carburant / Bränslepump / Pompa alimentazione				1	1	1	1	
2	1331 1333 865		Membrane / Diaphragm / Membrane / Membran / Membrana				1	1		1	
3	1331 1333 866		STI SHR M 8 x 20				2	2	2	2	
4	1331 1331 219		37,77 O-Ring / O-ring / Joint torique / O-ring / Anello-O				1	1	1	1	
5	07 11 9932 095		B 8 Federscheibe / Spring washer / Rondelle élastique / Fjäderbricka / Rosetta elastica				2	2	2	2	
6	07 11 9922 087		6 KT MU M 8				2	2	2		
7	a 1331 1331 220		Rohr / Tube / Tuyau / Rör / Tubo				1	1			
8	a 1331 1331 221		dito				1	1			
9	a 1331 1761 170		M 14 x 1,5 Hohlschraube / Banjo bolt / Vis creuse / Hålskruv / Vite cava				3	3	1	1	
10	a 07 11 9963 201		DTRG A 14				6	6			
11	a 07 11 9917 409		M 12 x 1,5 Hohlschraube / Banjo bolt / Vis creuse / Hålskruv / Vite cava				1	1			
12	07 11 9963 129		DTRG A 12,5				2	2			
13	a 1331 1331 217		Halter / Support / Support / Fäste / Sostegno				1	1			
14	a 1332 1331 215		dito				1	1			
15	07 11 9932 112		B 10 Federscheibe / Spring washer / Rondelle élastique / Fjäderbricka / Rosetta elastica				4	4			
16	07 11 9913 834		6 KT SHR M 10 x 25				4	4			
17	07 11 9913 843		6 KT SHR M 10 x 35				1	1			
18	a 1332 1331 216		Kraftstofffilter / Fuel filter / Filtre à carburant / Bränslefilter / Filtro carburante				1	1			
19	a 1332 1331 252		Kraftstofffilterpatrone / Fuel filter cartridge / Cartouche de filtre à combustible / Bränslefilterpatron / Cartuccia del filtro carburante				1	1			
20	a 1332 1333 869		Entlüftungsschraube / Vent screw / Vis de dégag. d'air / Luftningsbult / Vite di scarico dell'aria				1	1			
21	a 1332 1331 251		DTRG				1	1			
22	07 11 9913 442		6 KT SHR M 6 x 12				2	2			
23	07 11 9932 072		B 6 Federscheibe / Spring washer / Rondelle élastique / Fjäderbricka / Rosetta elastica				2	2			
24	07 11 9922 058		6 KT MU M 6				2	2			
25	07 11 9963 200		A 14 DTRG				2	2	2	2	

V12 Engineering  
 Box 50, Ontario, Canada POX 1C0  
[www.bmwmarine.net](http://www.bmwmarine.net)

a) → Mot. Nr. 652 (D150) → Mot. Nr. 6038 (D190)

www.bmwmarine.com

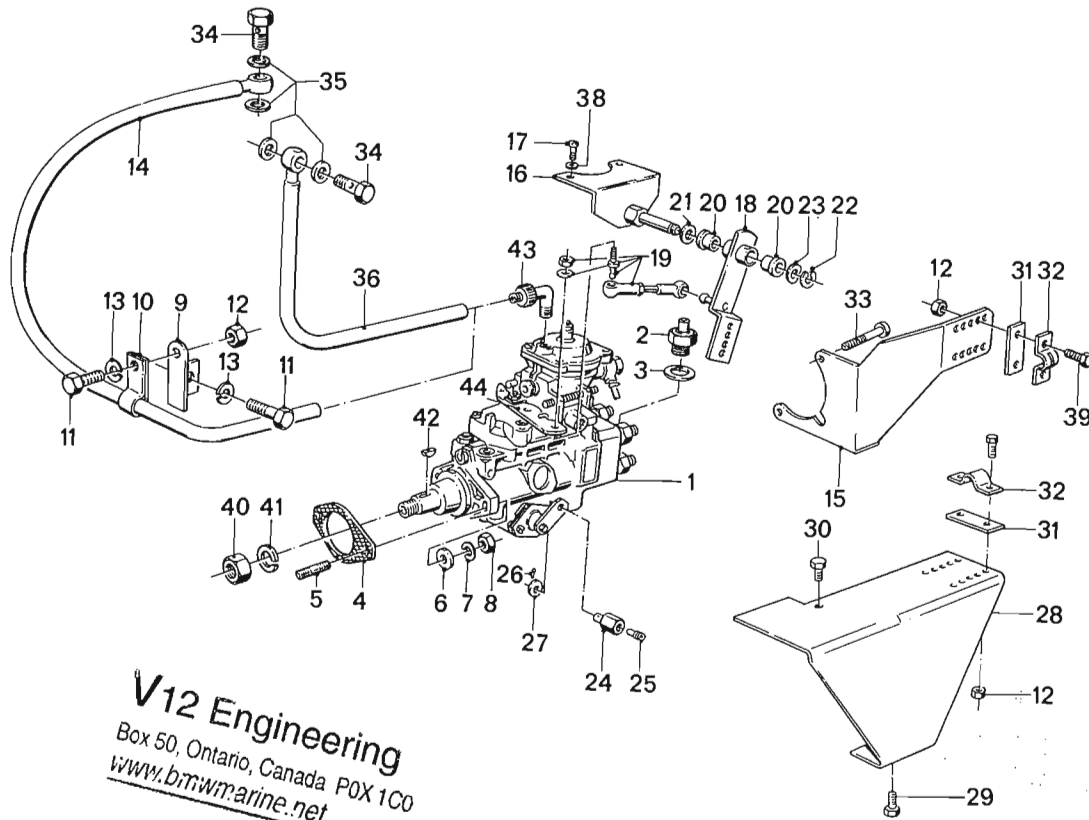

V12 Engineering  
Box 50, Ontario, Canada POX 1C0  
www.bmwmarine.net

13  
3/1  
D 150/D 190  
4/86

13 3/1		4/86										
Nr.	Teile-Nummer	Symbol	Benennung	D 150	D 190	D 530	D 636					Bemerkung
1	1351 1331 222		kpl. Einspritzpumpe / Injection pump / Pompe d'injection / Insprutningspump / Pompa d'iniezione	1								
	1351 1761 703		dito		1							
2	1351 1761 167		Zugmagnet / Traction magnet / Electro-aimant d'attraction / Dragmagnet / Elettromagnete di trazione	1	1							
3	1351 1761 168		O-Ring / O-ring / Joint torique / O-ring / Anello-O	1	1	1	1					
4	1351 1331 223		Dichtung / Seal / Garniture / Packing / Guarnizione	2	2							
5	1351 1333 870		STISHR M 8 x 28	2	2	3	3					
6	1351 1333 871		8,4 Scheibe / Washer / Rondelle / Bricka / Rondella	2	2	3	3					
7	07 119930 840		B 8 Federscheibe / Spring washer / Rondelle élastique / Fjäderbricka / Rosetta elastica	2	2	3	3					
8	1351 1331 756		6 KT MU M 8	2	2	3	3					
9	1353 1761 757		Halter / Support / Support / Fäste / Sostegno	1	1	1	1					
10	1353 1761 758		Schelle / Clamp / Collier / Klämna / Fascetta	1	1	1	1					
11	07 119913 218		6 KT SHR M 5 x 10	2	2	2	2					
12	07 119922 038		6 KT MU M 5	5	5	5	5					
13	07 119932 047		B 5 Federscheibe / Spring washer / Rondelle élastique / Fjäderbricka / Rosetta elastica	2	2	2	2					
14	b 1353 1763 467		Unterdruckrohr / Vacuum pipe / Tube de dépression / Vakuumrör / Tubo di depressione		1	1	1					
15	1321 1333 851		Haltewinkel / Support anlje / Corniere d'appui / Vinkelstöd / Squadra di sostegno	1	1							
16	1321 1761 674		Lagerwinkel / Bearing angle / Equerre de palier / Lagervinkel / Angolo del cuscinetto	1	1	1	1					
17	07 119913 466		6 KT SHR M 6 x 16	2	2	2	2					
18	1321 1761 672		Hebel / Lever / Levier / Spak / Leva	1	1	1	1					
19	1321 1333 856		Zugstange / Traction rod / Barre d'attelage / Dragstång / Tirante	1	1	1	1					
20	1354 1256 320		Buchse / Bushing / Douille / Bussning / Boccola	2	2	2	2					
21	07 119932 081		A 8 Federscheibe / Spring washer / Rondelle élastique / Fjäderbricka / Rosetta elastica	1	1	1	1					
22	07 119932 852		Sicherungsscheibe / Lock washer / Circlip / Låsbricka / Ranella di sicurezza	1	1	1	1					
23	07 119932 646		Scheibe / Washer / Rondelle / Bricka / Rondella	1	1	1	1					

a) → Aggr. Nr. 6521 (D 190)  
b) Aggr. Nr. → 6522 (D 190)

V12 Engineering  
www.bmwmarine.com

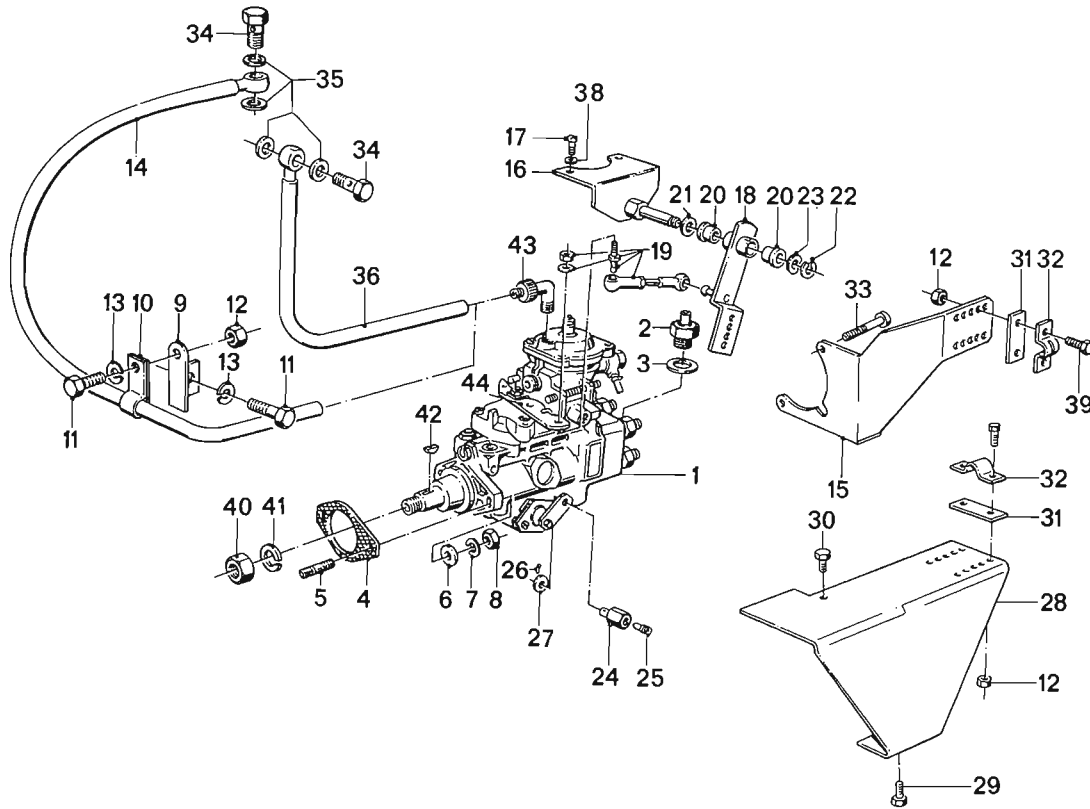

**13**  
**3/2**  
D 150/190  
4/86

13 3/2		4/86										
Nr.	Teile-Nummer	Symbol	Benennung	D 150	D 190	D 530	D 636					Bemerkung
24	13 21 1 331 256		Klemmstück / Clamping / Piece de serrage / Klämmdelar / Pezzo di serraggio	1	1	1						
25	07 11 9905 422		GEW STI M 6 × 10	1	1	1						
26	07 11 9945 113		Splint / Cotter pin / Goupille fendue / Splint / Copiglia	1	1	1						
27	07 11 9931 044		A 6,4 Scheibe / Washer / Rondelle / Bricka / Rondella	1	1	1						
28	13 21 1 331 172		Halteblech / Fixing plate / Plaque de support / Plåthållare / Lamiera di sostegno	1	1							
29	07 11 9913 807		6 KT SHR M 10 × 12	1	1							
30	07 11 9913 442		6 KT SHR	2	2							
31	13 21 1 330 287		Distanzblech / Spacing plate / Tôle d'écartement / Distanzbleck / Lamiera distanziatore	1	1	1	1					
32	13 21 1 326 574		Klemmbügel / Clampstrap / Etrier de serrage / Klämbügel / Staffa di serraggio	1	1	1	1					
33	13 21 1 761 847		ZYL SHR M 6 × 47	2	2		2					
34	13 53 1 333 874		Hohlschraube / Banjo bolt / Viscreuse / Hålskruv / Vite cava	1	1	1	1					
35	07 11 9963 072		A 10 DT RG	2	2	2	2					
36	a 13 53 1 331 250		Unterdruckrohr / Vacuum pipe / Tube de dépression / Vacuumrör / Tubo di depressione	1	1							
38	07 11 9931 652		6,4 Scheibe / Washer / Rondelle / Bricka / Rondella	2	2	2	2					
39	07 11 9913 218		6 KT SHR M 5 × 10	2	2							
40	07 11 9922 133		6 KT MUM 12	1	1	1	1					
41	07 11 9933 127		B 12 Federring / Spring lock washer / Rondelle élastique / Fjäderbricka / Anello elastico	1	1	1	1					
42	13 52 1 331 225		Scheibenfeder / Disk spring / Ressort en rondelle / Planfjäder / Molla per disco	1	1	1	1					
43	13 53 1 333 873		Ringstück / Ring piece / Pièce annulaire / Ringstycke / Pezzo annulare	1	1	1	1					
44	13 51 1 763 618		Hebel / Lever / Levier / Spak / Leva	1	1		1					

a) → Aggr. Nr. 6521 (D 190)  
b) Aggr. Nr. → 6522 (D 190)

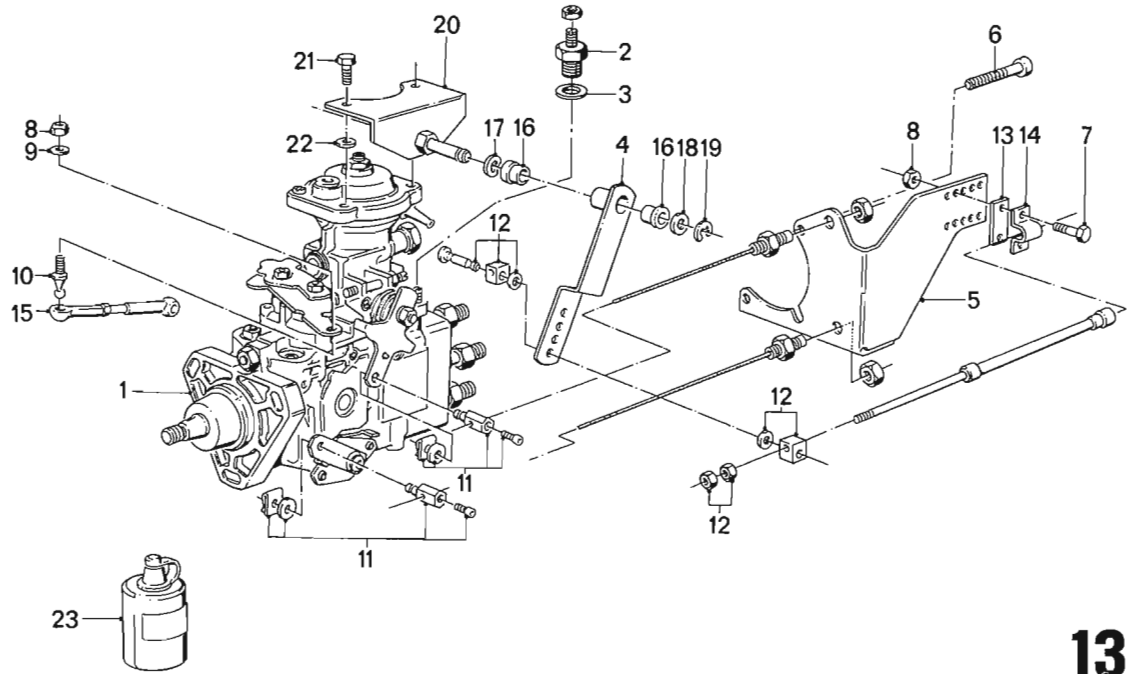

**13**  
**4/1**  
D 150/190/530/636  
4/86

<b>13</b> <b>4/1</b>		4/86					D 150	D 190	D 530	D 636	Bemerkung
Nr.	Teile-Nummer	Symbol	Benennung								
1	1351 1763 466		kpl. Einspritzpumpe / Injection pump / Pompe d'injection / Insprutningspump / Pompa d'iniezione						1		
	1351 1763 706		dito					1			
2	1351 1763 585		Druckmagnet / Pressure magnet / Aimant à pression / Tryckmagnet / Magnete di pressione					1	1		
3	1351 1761 168		O-Ring / O-ring / Joint torique / O-ring / Anello-O	1	1	1	1	1	1		
4	1321 1763 525		Hebel / Lever / Levier / Spak / Leva					1	1		
5	1321 1763 441		Haltewinkel / Support angle / Corniere d'appui / Vinkelstöd / Squadra di sostegno					1	1		
6	1321 1761 847		Zyl. SHR M 6 × 47					2	2		
7	07 11 9913 241		6 KT SHR M 5 × 16					2	2		
8	07 129 922 410		6 KT MU M 5					3	3		
9	07 11 9931 036		A 5,3 Scheibe / Washer / Rondelle / Bricka / Rondella					3	3		
10	07 11 9987 302		Kugelzapfen / Ball pin / Pivot spherique / Kultapp / Perno sferico					1	1		
11	1321 1761 662		Klemmstück / Clamping Piece de serrage / Klämmdelar / Pezzo di serraggio					2	2		
12	1321 1763 357		Schalteile / Shifting parts / Pièces de commande / Kopplingsdelar / Elemento di innesto					1	1		
13	1321 1330 287		Distanzblech / Spacing plate / Tôle d'écartement / Distanzbleck / Lamiera distanziatore	1	1	1	1	1	1		
14	1321 1326 574		Klemmbügel / Clamp strap / Etrier de serrage / Klämbygel / Staffa di serraggio	1	1	1	1	1	1		
15	1321 1333 856		Zugstange / Traction rod / Barre d'attelage / Dragstång / Tirante	1	1	1	1	1	1		
16	1354 1256 320		Büchse / Bushing / Douille / Bussning / Boccola	2	2	2	2	2	2		
17	07 11 9932 081		A 8 Federscheibe / Spring washer / Rondelle élastique / Fjäderbricka / Rosetta elastica	1	1	1	1	1	1		
18	07 11 9932 646		Passscheibe / Spacer shim / Disque d'ajustem. / Passbricka / Disco di aggiustaggio	1	1	1	1	1	1		
19	07 11 9932 852		7 - Sicherungsscheibe / Lock washer / Circlip / Låsbricka / Ranella di sicurezza	1	1	1	1	1	1		
20	1321 1761 674		Lagerwinkel / Bearing angle / Equerre de palier / Lagervinkel / Angolo del cuscinetto	1	1	1	1	1	1		



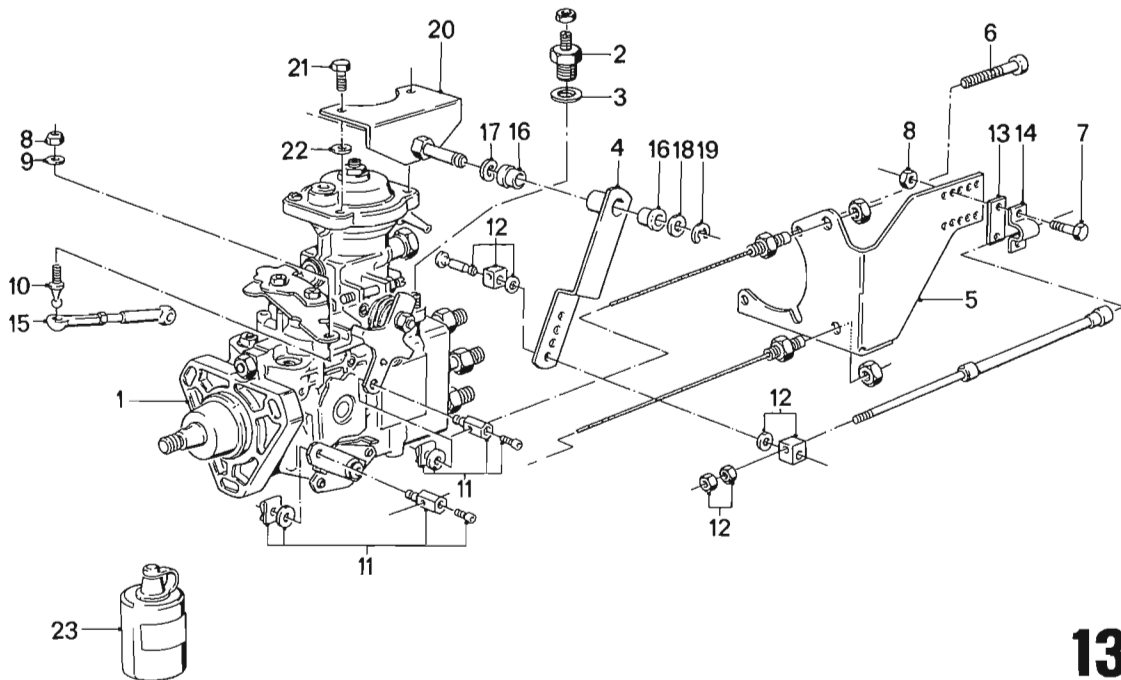

**13**  
**4/2**  
D 150/190/530/636  
4/86

13 4/2		4/86									
Nr.	Teile-Nummer	Symbol	Benennung	D 150	D 190	D 530	D 636	Bemerkung			
21	07 11 9913 466		6 KT SHR M 6 × 16	2	2	2	2				
22	07 11 9931 652		6,4 Scheibe / Washer / Rondelle / Bricka / Rondella	2	2	2	2				
23	07 58 9056 979		Flüssigdichtmittel / Liquid sealing material / Produit liquide d'étanchéité / Flytande tättningsmedel / Materiale sigillante liquido			1	1				
24	13 51 1763 618		Hebel / Lever / Levier / Spak / Leva	1	1	1	1				

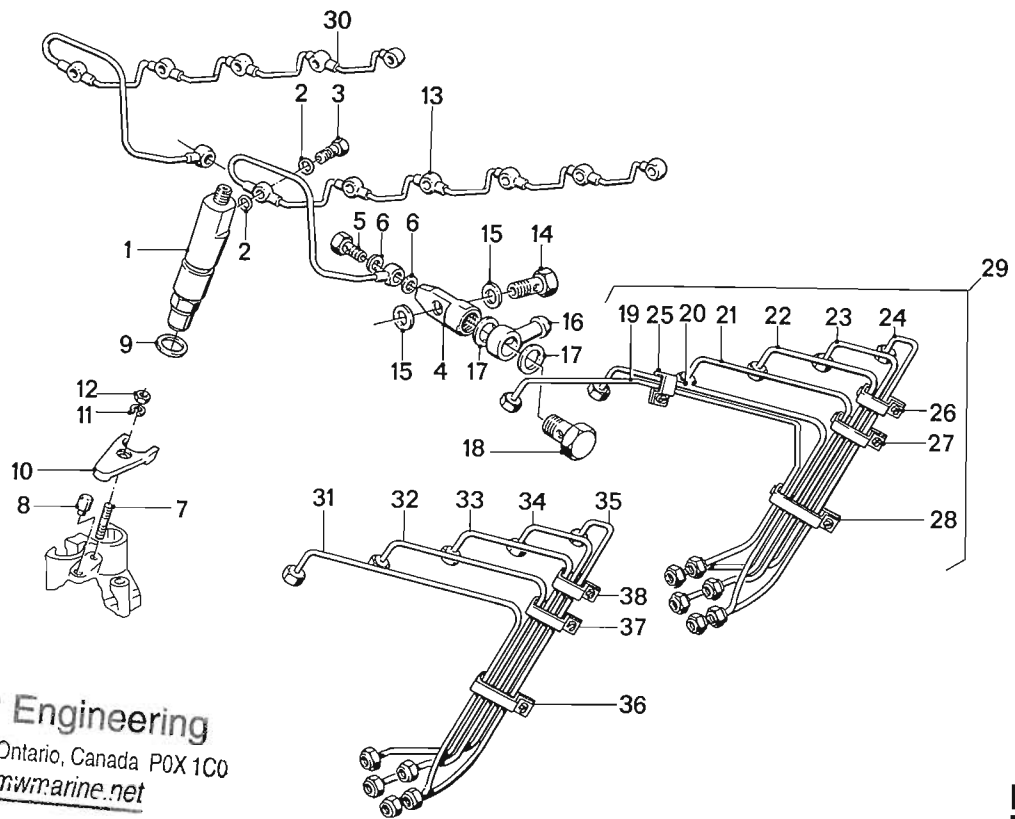

V12 Engineering  
Box 50, Ontario, Canada P0X 1C0  
[www.bmwmarine.net](http://www.bmwmarine.net)

13  
5/1

D 150/190/530/636  
4/86

13 5/1		4/86					D 150	D 190	D 530	D 636		
Nr.	Teile-Nummer	Symbol	Benennung								Bemerkung	
1	1353 1331 226		kpl. Einspritzdüse / Injection nozzle / Injecteur de carburant / Insprutningsmunstycke / Iniettore del carburante				6	6	5	6		
2	07 11 9963 034		DTRG				12	12	10	12		
3	1353 1331 233		M 6 x 1 Hohlschraube / Banjo bolt / Vis creuse / Hålskruv / Vite cava				6	6	5	6		
4	1353 1761 163		Verteilerstück / Air divider / Pièce de distribution / Fördelarstycke / Distributore				1	1	1	1		
5	1353 1761 165		M 8 x 1 Hohlschraube / Banjo bolt / Vis creuse / Hålskruv / Vite cava				1	1	1	1		
6	07 11 9963 042		A 8 DTRG				2	2	2	2		
7	1353 1333 875		STI SRH M 8 x 35				6	6	5	6		
8	1353 1331 235		Distanzstück / Spacer / Entretoise / Distanstycka / Pezzo distanziatore				6	6	5	6		
9	1353 1331 234		DTRG				6	6	5	6		
10	1353 1331 236		Klemmpratze / Clamping shoe / Patte de serrage / Klämsax / Dispositivo di serraggio				6	6	5	6		
11	07 11 9933 096		A 8 Federscheibe / Spring washer / Rondelle élastique / Fjäderbricka / Rosetta elastica				6	6	5	6		
12	07 11 9922 087		6 KT MU				6	6	6	6		
13	1353 1331 240		Rücklaufleitung / Return pipe / Conduite de retour / Aterloppsledning / Conduittura di ritorno				1	1	1	1		
14	1353 1761 166		Entlüftungsschraube / Vent screw / Vis de dégag. d'air / Luftningsbult / Vite di scarico dell'aria				1	1	1	1		
15	07 11 9963 129		A 12 DTRG				2	2	2	2		
16	1331 1761 169		Ringstück / Ring piece / Pièce annulaire / Ringstycke / Pezzo annulare				1	1	1	1		
17	07 11 9963 201		A 14 DTRG				2	2	2	2		
18	1331 1761 170		Hohlschraube / Banjo bolt / Vis creuse / Hålskruv / Vite cava				1	1	1	1		
19	1353 1331 242		Zyl. 1 Druckrohr / Pressure pipe / Tube de pression / Tryckrör / Condotta forzata				1	1	1	1		
20	1353 1331 243		Zyl. 2 dito				1	1	1	1		
21	1353 1331 244		Zyl. 3 dito				1	1	1	1		
22	1353 1331 245		Zyl. 4 dito				1	1	1	1		
23	1353 1331 246		Zyl. 5 dito				1	1	1	1		
24	1353 1331 247		Zyl. 6 dito				1	1	1	1		

V12 Engineering  
www.bmwmarine.com

Einspritzleitung  
Injection line  
Conduite d'injection  
Insprutningsledning  
Tubo d'iniezione

BMW D 150 / D 190 / D 530 / D 636

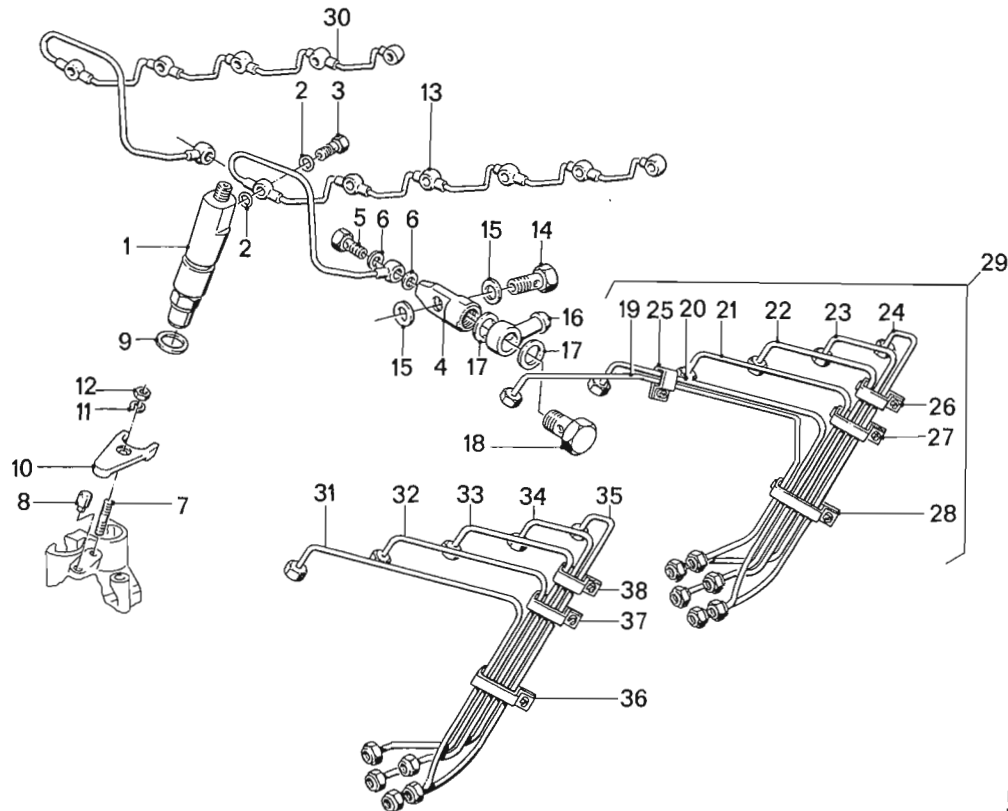

**13**  
**5/2**  
D 150/190/530/636  
4/86

13 5/2		4/86									
Nr.	Teile-Nummer	Symbol	Benennung				D 150	D 190	D 530	D 636	Bemerkung
25	1353 1331 248		Schelle / Clamp / Collier / Klämme / Fascetta				1	1	1		
26	1353 1331 249		dito				1	1	1		
27	1353 1331 238		dito				1	1	1		
28	1353 1331 239		dito				1	1	1		
29	1353 1331 241		kpl. Einspritzleitung / Injection line / Conduite d'injection / Insprutningsledning / Tubo d'iniezione				1	1	1		
30	1353 1763 718		Rücklaufleitung / Return pipe / Conduite de retour / Aaterloppsledning / Conduittura di ritorno						1		
31	1353 1763 709		Zyl. 1 Druckrohr / Pressure pipe / Tube de pression / Tryckrör / Condotta forzata								
32	1353 1763 710		Zyl. 2 dito						1		
33	1353 1763 711		Zyl. 3 dito						1		
34	1353 1763 712		Zyl. 4 dito						1		
35	1353 1763 713		Zyl. 5 dito						1		
36	1353 1763 714		Schelle / Clamp / Collier / Klämme / Fascetta						2		
37	1353 1763 716		dito						1		
38	1353 1763 717		dito						1		

V12 Engineering

www.bmwmarine.com

Luftfilter  
Air cleaner  
Filtre à air  
Luftfilter  
Filtro aria

BMW D 150 / D 190 / D 530 / D 636

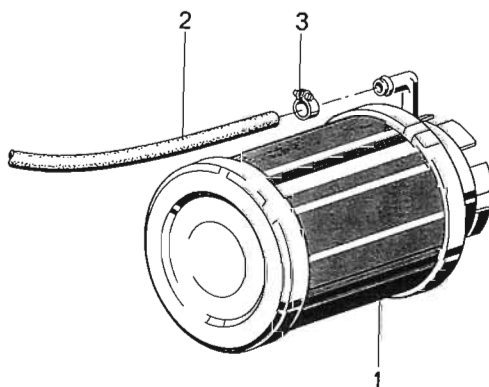

**13**  
**6**  
D 150/D 190  
4/86

13 6		4/86						
Nr.	Teile-Nummer	Symbol	Benennung	D 150	D 190	D 530	D 636	Bemerkung
1	a 1372 1331 128		Luftfilter / Air cleaner / Filtre à air / Luftfilter / Filtro aria	1	1			
2	a 1372 1331 203		Schlauch / Hose / Tuyau / Slang / Tubo flessibile	1	1			
3	a 1153 1326 638		16-25 Schelle / Coil clip / Collier / Klammer / Fascetta	1	1			

a) → Aggr. Nr. 771 (D 150) / → 6402 (D 190)

Luftfilter  
Air cleaner  
Filtre à air  
Luftfilter  
Filtro aria

BMW D 150 / D 190 / D 530 / D 636

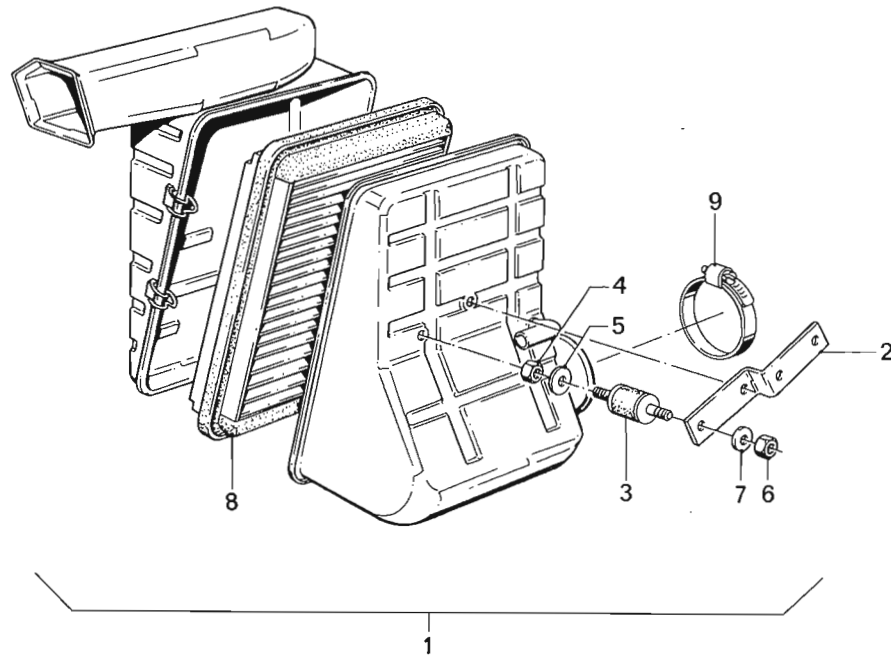

**13**  
**7**  
D 150/D 190  
4/86

13 7		4/86									
Nr.	Teile-Nummer	Symbol	Benennung	D 150	D 190	D 530	D 636	Bemerkung			
1	a 1371 1761575		kpl. Luftfilter / Air cleaner / Filtre à air / Luftfilter / Filtro aria	1	1						
2	a 1371 1761816		Halter / Support / Support / Fäste / Sostegno	1	1						
3	a 1371 1761817		Gummipuffer / Cushioning / Tampon de caoutchouc / Gummibuffert / Tampone di gomma	2	2		3				
4	a 07 119922058		6 KT MU M 6	2	2						
5	a 1371 1761820		Spannscheibe / Conical spring washer / Rondelle élastique bombée / Spännskiva / Rondella tenditrice	2	2		3				
6	a 07 119922417		6 KT MU M 6	2	2		6				
7	a 07 119936425		A 6,4 Scheibe / Washer / Rondelle / Bricka / Rondella	2	2		3				
8	a 1371 1761579		Einsatz / Element / Élément amovible / Insats / Elemento amovibile	1	1						
9	a 1153 1328048		Ø 40-60 Schelle / Coil clip / Collier / Klammer / Fascetta	1	1						

a) Aggr. Nr. → 772 (D 150) 6403 (D 190)

Luftfilter  
Air cleaner  
Filtre à air  
Luftfilter  
Filtro aria

BMW D 150 / D 190 / D 530 / D 636

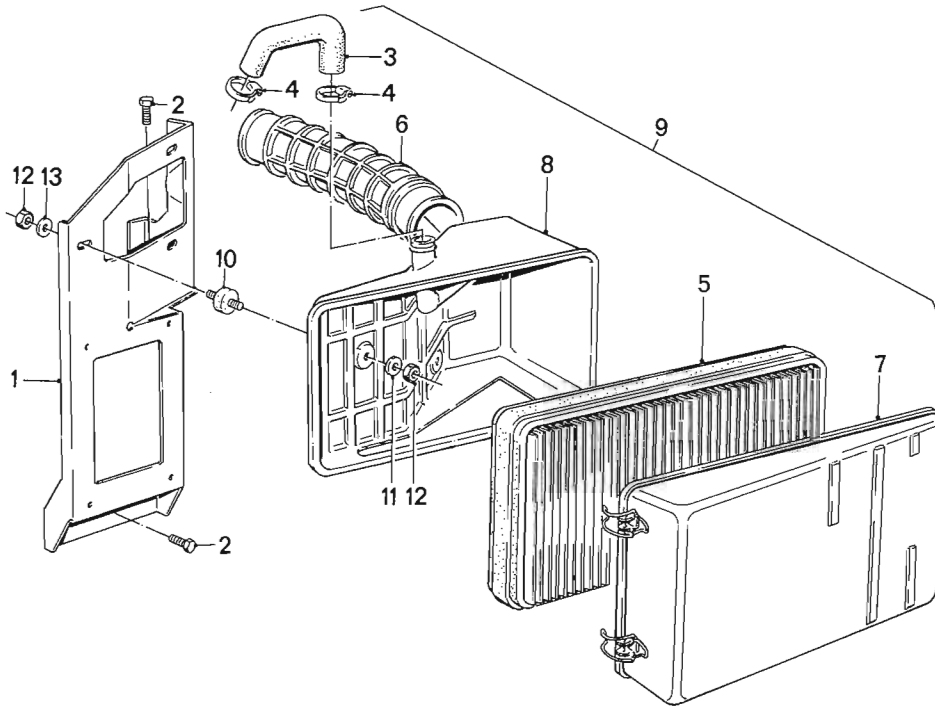

**13**  
**8**  
D 530/636  
4/86

<b>13</b> <b>8</b>		4/86					D 150	D 190	D 530	D 636	Bemerkung
Nr.	Teile-Nummer	Symbol	Benennung								
1	13 71 1 763 253		Halteblech / Rataining plate / Tôle de retenue / Fästplåt / Lamiera di sostegno						1	1	
2	07 11 9 913 815		6KT SHR						2	2	
3	13 72 1 763 278		Luftschlauch / Air hose / Tuyau d'air / Luftslang / Tubo flessibile aria							1	
	13 72 1 763 508		dito						1	1	
4	07 12 9 952 111		23-29 Schlauchschelle / Hose clamp / Collier de flexible / Slangklämma / Collare per tubo flessibile						1	2	
5	13 71 1 761 579		Luftfiltereinsatz / Air filter element / Element filtre a air / Luftfiltereinsatz / Elemento filtro aria						1	1	
6	13 71 1 763 523		Formschlauch / Preformed hose / Tuyau préformé / Slang / Tubo flessibile sagomato							1	
7	13 71 1 763 325		Oberteil / Top part / Partier supérieur / Överdel / Parte superiore						1	1	
8	13 71 1 763 328		Unterteil / Lower part / Partier inférieure / Underdel / Parte inferiore						1	1	
9	13 71 1 763 323		kpl. Luftfilter / Air cleaner / Filtre à air / Luftfilter / Filtro aria						1	1	
10	13 71 1 761 817		Gummipuffer / Cushioning / Tampon de caoutchouc / Gummibuffert / Tampone di gomma				2	2	3	3	
11	07 11 9 936 425		6,4 Scheibe / Washer / Rondelle / Bricka / Rondella				2	2	3	3	
12	07 12 9 922 417		6KT MU M 6				2	2	3	6	
13	13 71 1 761 820		6 Spannscheibe / Conical spring washer / Rondelle élastique bombée / Spännskiva / Rondella tenditrice				2	2	3	3	

V12 Engineering  
Box 50, Ontario, Canada POX 1C0  
[www.bmwmarine.net](http://www.bmwmarine.net)

V12 Engineering  
www.bmwmarine.com



Sammelleiste  
 Manifold strip  
 Réglette collectrice  
 Samlingslist  
 Regolo collettore

BMW D 150 / D 190 / D 530 / D 636

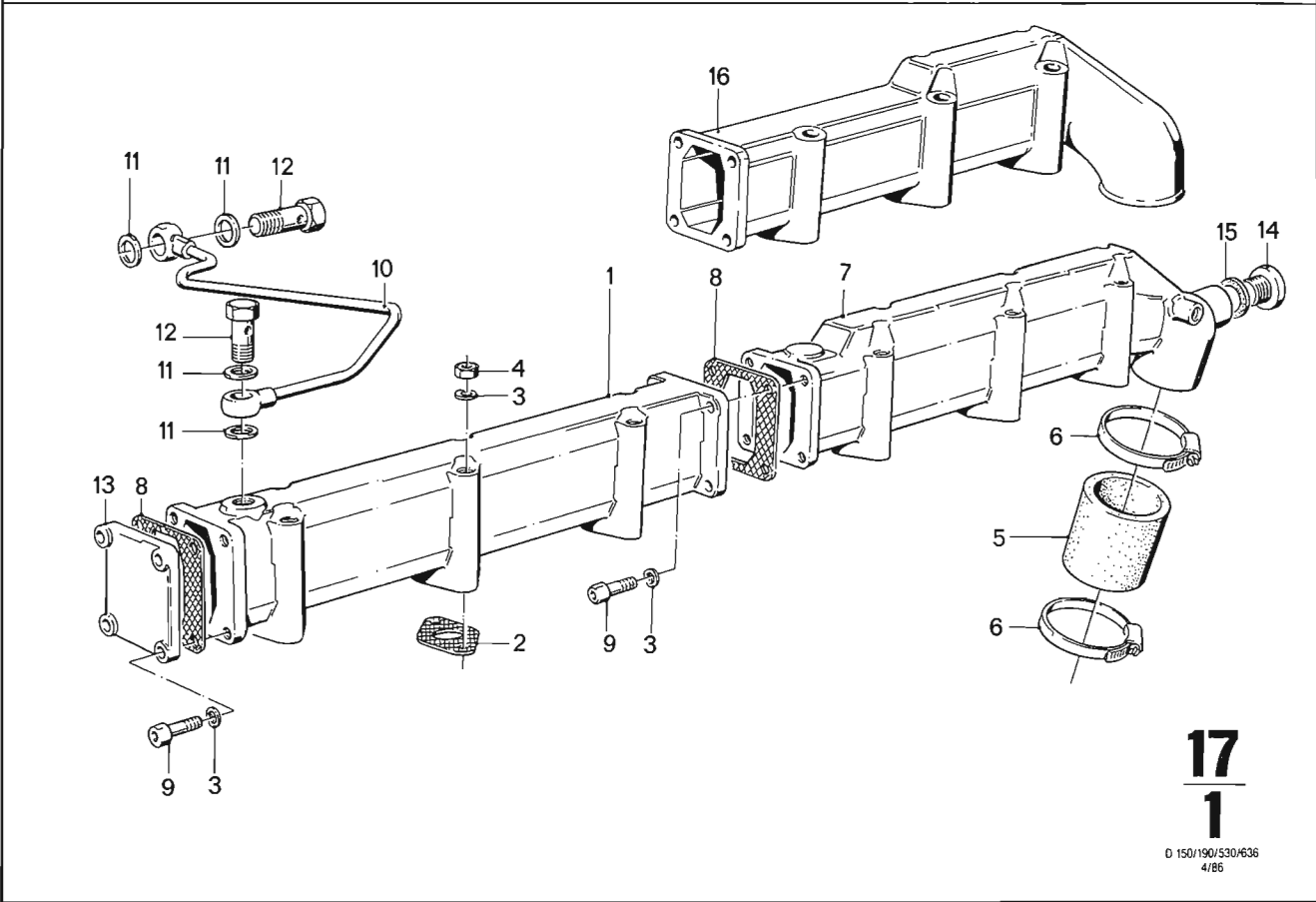

**17**  
**1**

D 150/190/530/636  
4/86

<b>17</b> <b>1</b>		4/86									
Nr.	Teile-Nummer	Symbol	Benennung	D 150	D 190	D 530	D 636	Bemerkung			
1	17 12 1761 097		Sammelleiste vorne / Manifold strip, front / Réglette collectrice avant / Samlingslist, främre / Regolo collettore anteriore	1	1	1					
	17 12 1763 724		dito			1					
2	17 12 1331 204		Dichtung / Seal / Garniture / Packning / Guarnizione	6	6	6	6				
3	07 11 9932 072		B 6 Federscheibe / Spring washer / Rondelle élastique / Fjäderbricka / Rosetta elastica	20	20	20	20				
4	07 11 9922 058		6 KT MU M 6	12	12	12	12				
5	17 12 1331 197		Schlauch / Hose / Tuyau / Slang / Tubo flessibile	1	1						
6	11 53 1328 048		Ø 40-60 Schelle / Clamp / Collier / Klämme / Fascetta	2	2						
7	17 12 1331 142		Sammelleiste hinten / Manifold strip, rear / Réglette collectrice, arrière / Samlingslist, bakre / Regolo collettore posteriore, dietro	1	1						
8	17 12 1331 205		Dichtung / Seal / Garniture / Packning / Guarnizione	2	2	2	2				
9	07 11 9919 967		ZYL SHR M 6 x 20	8	8	8	8				
10	17 12 1761 289		Entlüftungsleitung / Vent line / Conduite d'aération / Ventilationsledning / Tubo di disaerazione	1	1	1	1				
11	07 11 9963 130		DTRG A 12	4	4		5				
12	07 11 9917 409		Hohlschraube / Banjo bolt / Vis creuse / Hålskruv / Vite cava	2	2	1	1				
13	17 12 1761 418		Deckel / Cover / Couvercle / Lock / Coperchio	1	1	1	1				
14	07 11 9919 131		VSL SHR M 22 x 1,5	1	1						
15	07 11 9963 355		DTRG A 22	1	1						
16	17 12 1763 471		Sammelleiste hinten / Manifold strip, rear / Réglette collectrice, arrière / Samlingslist, bak / Regolo collettore posteriore			1	1				

V12 Engineering  
 Box 50, Ontario, Canada POX 100  
[www.bmwmarine.net](http://www.bmwmarine.net)

V12 Engineering  
 www.bmwmarine.com



Kühlwasserbehälter  
Cooling water tank  
Reservoir d'eau de refroidissement  
Kylvattentank  
Recipiente dell'acqua di raffreddamento

BMW D 150 / D 190 / D 530 / D 636

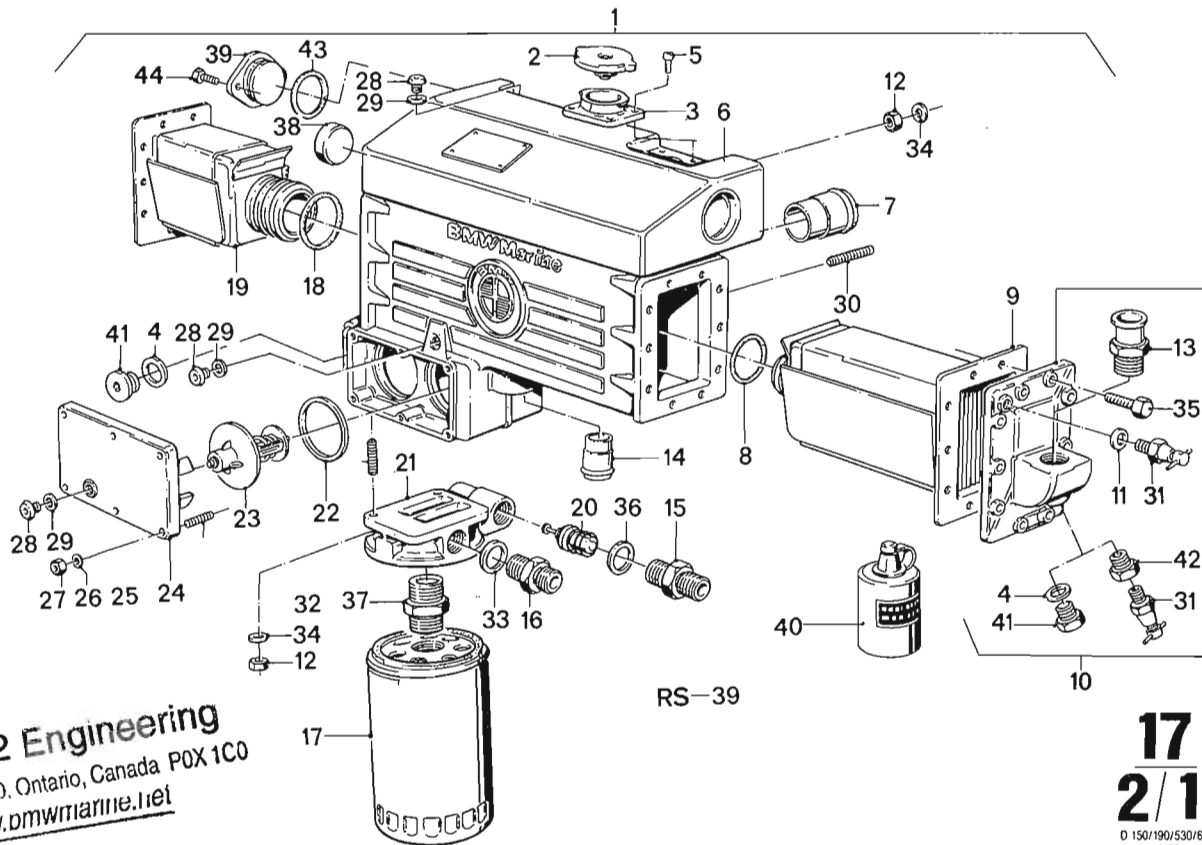

V12 Engineering  
Box 50, Ontario, Canada P0X 1C0  
www.dmwmarine.net

RS-39

17  
2/1  
D 150/190/530/636  
4/86

17 2/1		4/86							
Nr.	Teile-Nummer	Symbol	Benennung	D 150	D 190	D 530	D 636	Bemerkung	
1	a 17 11 1761 002	RS	kpl. Kühlwasserbehälter / Cooling water tank / Reservoir d'eau de refroidissement / Kylvattentank / Recipiente dell'acqua di raffreddamento	1					
	a 17 11 1761 885	RS	dito		1				
	17 11 1763 334		dito		1	1	1		
2	1153 1328 892		Kühlerverschluß / Radiator cap / Bouchon de radiateur / Kylare lock / Tappo radiatore	1	1	1	1		
3	1153 1326 498		Füllstutzenbecher / Filler cup / Godet de tubulure de remplissage / Pätylliningsrörets bägare / Coppa del bocchettone di riempimento	1	1	1	1		
4	07 11 9963 290		DT RGA 17	2	2				
5	07 11 9919 965		ZYL SHR M 6 x 16	4	4	4	4		
6	17 11 1763 288		Kühlwasserbehälter / Cooling water tank / Reservoir d'eau de refroidissement / Kylvattentank / Recipiente dell'acqua di raffreddamento	1	1		1		
	17 11 1763 293		dito			1			
	17 11 1761 171		Ø 44,5 Rohrstutzen / Adapter / Raccord de tuyaux / Förbindningsrör / Bocchettone	1	1	1	1		
8	17 11 1331 190		O-Ring / O-ring / Joint torique / O-ring / Anello-O	2	2	2	2		
9	a 17 11 1331 134		Kühlereinsatz - Wasser - Wasser / Radiator insert - water - water / Element de radiateur - eau - eau / Radiatorinsats - vatten - vatten / Inserzione radiatore - acqua - acqua	1					
	17 11 1761 076		dito	1	1	1	1		
10	a 17 11 1331 132		kpl. Seitendeckel / Side cover / Couvercle latéral / Sidolock / Coperchio laterale	2					
	17 11 1761 082		dito	2	1				
	17 11 1761 884		dito		1	2	2		
11	07 11 9963 201		DT RGA 14	2	2	2	2		
12	07 11 9922 087		6KT MUM 8	20	20	20	20		
13	a 11 62 1 328 839		Stutzen / Connection / Tubulare / Stuts / Bocchettone	2					
	17 11 1761 273		Einschraubstutzen / Male connector / Raccord fileté / Skruvstuts / Tronchetto filettato	2	2	2	2		
14	11 62 1 326 732		Ø 26 dito	1	1	1	1		
15	17 22 1 331 152		Einschraubstutzen / Male connector / Raccord fileté / Skruvstuts / Tronchetto filettato	1	1	1	1		

a) Nur erforderlich für altes Kühlgefäß → Aggr. Nr. 453 / Only necessary for old cooling vessel → Aggr. Nr. 453 /  
Nécessaire uniquement pour bac de réfrigération ancien → Aggr. Nr. 453 / Bara nödvändig för gammal kyltank → Aggr. Nr. 453 /  
Necessario solo per recipiente di raffreddamento vecchio → Aggr. Nr. 453

V12 Engineering

Kühlwasserbehälter  
Cooling water tank  
Reservoir d'eau de refroidissement  
Kylvattentank  
Recipiente dell'acqua di raffreddamento

BMW D 150 / D 190 / D 530 / D 636

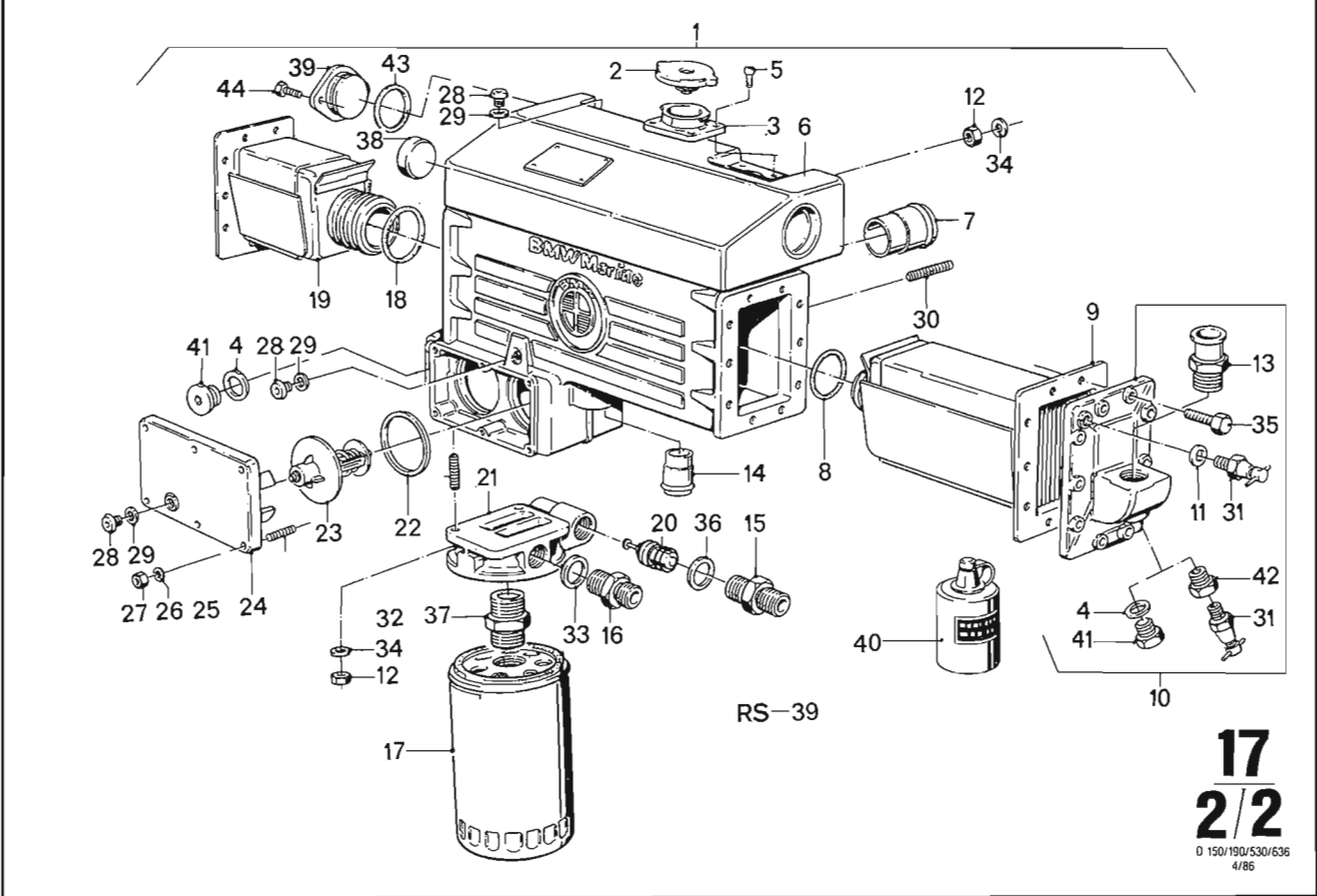

**17**  
**2/2**  
D 150/190/530/636  
4/86

17 2/2		4/86					D 150	D 190	D 530	D 636		
Nr.	Teile-Nummer	Symbol	Benennung							Bemerkung		
16	07 11 9964 543		Stutzen / Connection / Tubulare / Stuts / Bocchettone	1	1	1	1					
17	17 22 1 331 206		Ölfilterpatrone / Oil filter cartridge / Cartouche de filtre à huile / Oljefilterpatron / Cartuccia filtro dell'olio	1	1							
	17 22 1 763 296		dito			1	1					
18	17 21 1 331 189		O-Ring / O-ring / Joint torique / O-ring / Anello-O	2	2	2	2					
19	a 17 11 1 331 135		Kühlereinsatz - Öl - Wasser / Radiator insert - oil - water / Element de radiateur - huile - eau / Radiatorinsats - olje-vatten / Inserzione radiatore - olio - acqua	1								
	17 21 1 761 077		dito	1	1	1	1					
20	17 22 1 331 165		Öltemperaturgeber / Oil temperature transmitter / Transmetteur de température d'huile / Oljetemperaturgivare / Trasmittitore temperatura dell'olio	1	1		1					
21	17 22 1 331 192		kpl. Ölfilterkopf / Oil filter head / Tête de filtre à huile / Oljefilterhuvud / Testata filtro olio	1	1							
	17 22 1 763 336		dito			1	1					
22	11 53 1 250 399		Dichtung / Seal / Garniture / Packning / Guarnizione	2	2	2	2					
23	11 53 1 326 809		Thermostat / Thermostat / Thermostat / Termostat / Termostato	2	2	2	2					
24	11 53 1 331 150		Thermostatdeckel / Thermostat cover / Covercle de thermostat / Termostatlock / Coperchio del termostato	1	1	1	1					
25	07 12 9908 111		STI SHR M6 x 28	6	6	6	6					
26	07 11 9932 072		B6 Federscheibe / Spring washer / Rondelle élastique / Fjäderbricka / Rosetta elastica	6	6	6	6					
27	07 11 9922 058		6 KT MU	6	6	6	6					
28	07 11 9919 114		VSL SHR M 14 x 1,5	3	3	3	3					
29	07 11 9963 200		DT RG A 14	3	3	3	3					
30	07 11 9909 067		STI SHR M8 x 20			4	4					
31	17 12 1 763 335		1/4 Ablasshahn / Drain cock / Robinet de vidange / Utloppskran / Rubinetto di scarico	2	2	2	2					
32	07 12 9908 132		STI SHR M8 x 35	4	4	4	4					
33	07 11 9963 355		DT RG A 22	1	1	1	1					
34	07 11 9932 095		B8 Federscheibe / Spring washer / Rondelle élastique / Fjäderbricka / Rosetta elastica	8	8	8	8					

a) Nur erforderlich für altes Kühlgefäß → Aggr. Nr. 453 / Only necessary for old cooling vessel → Aggr. Nr. 453 /  
Nécessaire uniquement pour bac de réfrigération ancien → Aggr. Nr. 453 / Bara nödvändig för gammal kyltank → Aggr. Nr. 453 /  
Necessario solo per recipiente di raffreddamento vecchio → Aggr. Nr. 453

V12 Engineering  
www.bmwmarine.com

Kühlwasserbehälter  
 Cooling water tank  
 Reservoir d'eau de refroidissement  
 Kylvattentank  
 Recipiente dell'acqua di raffreddamento

BMW D 150 / D 190 / D 530 / D 636

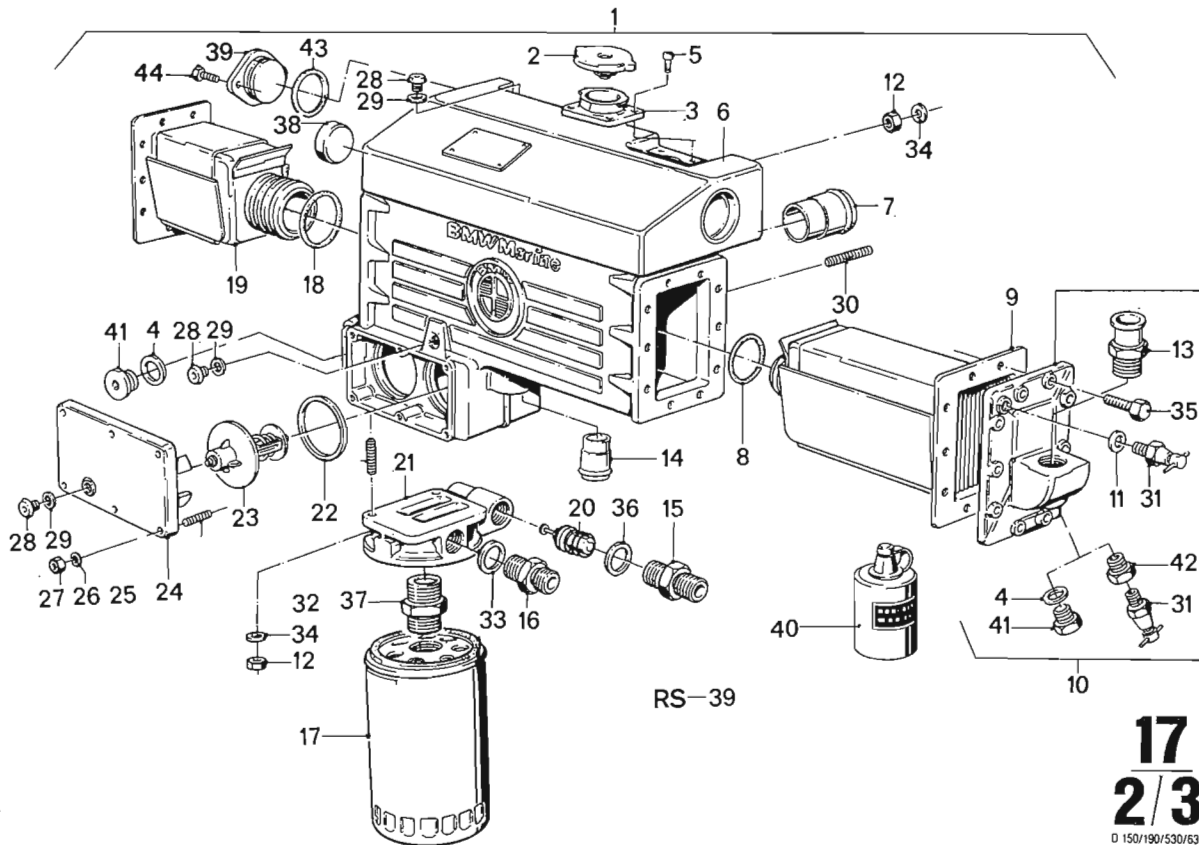

RS-39

**17**  
**2/3**  
 D 150/190/530/636  
 4/86

17 2/3		4/86									
Nr.	Teile-Nummer	Symbol	Benennung				D 150	D 190	D 530	D 636	Bemerkung
35	07 11 9913 657		6 KT SHRM 8 x 25				20	20	20	20	
36	07 11 9963 467		DTRG A 36				1	1	1	1	
37	17 22 1 331 137		Einschraubstutzen / Male connector / Raccord fileté / Skruvstuts / Tronchetto filettato				1	1	1	1	
38	07 11 9937 332		45 VSL Deckel / Cover / Couverture / Lock / Coperchio				1	1	1	1	
39	17 11 1 763 299		Deckel / Cover / Couverture / Lock / Coperchio						1	1	
40	07 58 9 056 979		Flüssigdichtmittel / Liquid sealing material / Produit liquide d'étanchéité / Flytande tättningsmedel / Materiale sigillante liquido				1	1	1	1	
41	17 11 1 763 264		VSL SHR 1/8					1	2	2	
	07 11 1 763 263		dito 3/8				2				
42	17 11 1 763 221		Reduzierstück / Reduzer / Réduction / Reduktion / Elemento di riduzione					1	1	1	
43	17 11 1 763 303		O-Ring / O-ring / Joint torique / O-ring / Anello-O						1	1	
44	07 11 9900 816		SK SHRM 6 x 16						2	2	

a) Nur erforderlich für altes Kühlgefäß → Aggr. Nr. 453 / Only necessary for old cooling vessel → Aggr. Nr. 453 / Nécessaire uniquement pour bac de réfrigération ancien → Aggr. Nr. 453 / Bara nödvändig för gammal kyltank → Aggr. Nr. 453 / Necessario solo per recipiente di raffreddamento vecchio → Aggr. Nr. 453

V12 Engineering

www.bmwmarine.com

Abstützung  
 Propp  
 Support  
 Stöttning  
 Supporto

BMW D 150 / D 190 / D 530 / D 636

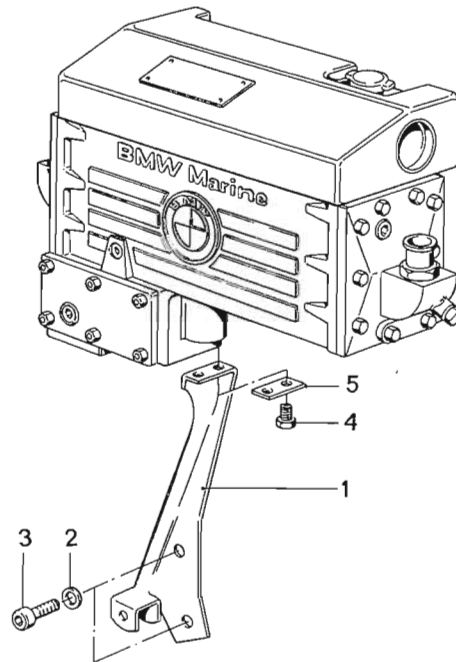

**17**  
**3**  
 D 636  
 4/86

17 3		4/86					D 150	D 190	D 530	D 636		
Nr.	Teile-Nummer	Symbol	Benennung								Bemerkung	
1	17 11 1763 473		Abstützung / Propp / Support / Stöttning / Supporto						1	1		
2	07 11 9931 682		15 Scheibe / Washer / Rondelle / Bricka / Rondella						2	2		
3	07 11 9920 066		Zyl. SHR M 14 x 25						2	2		
4	07 11 9919 978		Zyl. SHR M 8 x 25						2	2		
5	17 11 1763 277		Unterlage / Spacer / Joint / Underlägg / Piastrina						1	1		

V12 Engineering  
 www.bmwmarine.com

Abstützung  
Propp  
Support  
Stöttning  
Supporto

BMW D 150 / D 190 / D 530 / D 636

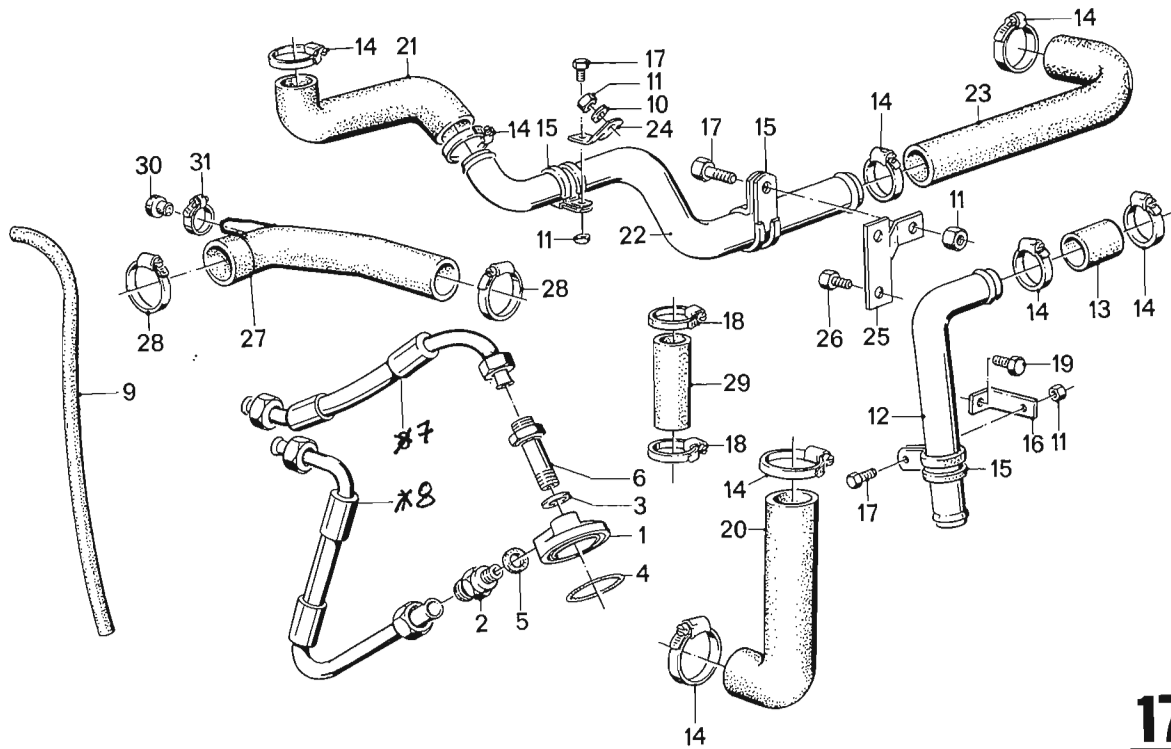

17  
4/1

D 150/190/530/636  
4/86

17 4/1		4/86					D 150	D 190	D 530	D 636	Bemerkung
Nr.	Teile-Nummer	Symbol	Benennung								
1	17 21 1 331 148		Deckel / Cover / Couvercle / Lock / Coperchio				1	1	1	1	
2	07 11 9 964 543		Stutzen / Connection / Tubulare / Stuts / Bocchettone				1	1	1	1	
3	07 11 9 963 355		DTRG A 22				1	1	1	1	
4	17 22 1 331 195		O-Ring / O-ring / Joint torique / O-ring / Anello-O				1	1	1	1	
5	07 11 9 963 342		DTRG A 20				1	1	1	1	
6	17 22 1 331 151		Hohlschraube / Banjo bolt / Vis creuse / Hålskruv / Vite cava				1	1	1	1	
7	17 22 1 761 340		Ölleitung – Motor – Thermostat / Oil line – engine – thermostat / Conduite d'huile – moteur – thermostat / Oljeledning – motor – thermostat / Tubatura olio – motore – termostato				1	1	1	1	
8	17 22 1 761 339		Ölleitung – Ölfilter – Motor / Oil line oil filter engine / Conduite d'huile entre filtre à huile et moteur / Oljeledning för motorns oljefilter / Tubazione dell'olio i filtro dell'olio – motore				1	1	1	1	
9	17 11 1 333 883		Schlauch / Hose / Tuyau / Slang / Tubo flessibile				1	1	1	1	
10	07 11 9 931 067		A 8,4 Scheibe / Washer / Rondelle / Bricka / Rondella				3	3			
11	07 11 9 922 087		6KT MUM 8				6	6	1	1	
12	b 17 12 1 331 163		Rohr / Tube / Tuyau / Rör / Tubo				1	1	1	1	
13	b 17 12 1 331 112		Schlauch / Hose / Tuyau / Slang / Tubo flessibile				1	1	1	1	
14	11 53 1 326 639		Ø 32–50 Schelle / Clamp / Collier / Klämna / Fascetta				8	8	2	2	
15	17 12 1 331 113		Rohrschelle / Pipe clamp / Bride de tuyau / Rörklämna / Fascetta di tubo				2	2	1	2	
16	17 11 1 331 164		Haltewinkel / Support angle / Corniere d'appui / Vinkelstöd / Squadra di sostegno				1	1	1	1	
17	07 11 9 913 624		6KT SHR M 8 x 16				3	3	1	1	
18	11 53 1 326 523		Ø 25–40 Schelle / Clamp / Collier / Klämna / Fascetta				2	2	2	2	
19	07 11 9 913 815		6KT SHR M 10 x 16				1	1	1	1	
20	17 12 1 331 159		Krümmer / Elbow / Coude / Krök / Gomito				1				
21	17 12 1 331 157		dito				1	1			
a	17 12 1 761 379		dito				1	1			
22	17 12 1 331 154		Rohr / Tube / Tuyau / Rör / Tubo				1	1			
a	17 12 1 761 380		dito				1	1			
23	17 12 1 331 158		Krümmer / Elbow / Coude / Krök / Gomito				1	1			
24	17 12 1 331 155		Halter / Support / Support / Fäste / Sostegno				1	1			
25	17 11 1 331 156		dito				1	1			
26	07 11 9 913 616		6KT SHR M 8 x 12				2	2			
27	17 12 1 333 484		Krümmer / Elbow / Coude / Krök / Gomito				1	1			
	17 12 1 763 295		dito						1	1	

V12 Engineering  
Box 50, Ontario, Canada P0X 1C0  
www.bmwmarine.net

- a) Nur Verwendbar bei neuem Luftfilter / Only to be used with new air filter /  
Utilisable uniquement pour nouveaux filtre à air / Användbar bara vid nytt luftfilter / Utilizzabile solo a filtro selettivo nuovo
- b) Nur für Z-Antrieb / For gear drive only / Uniquement pour Commande per engrènement / Bara för Kugghjulsdrevning / Solo comando per ingranaggi

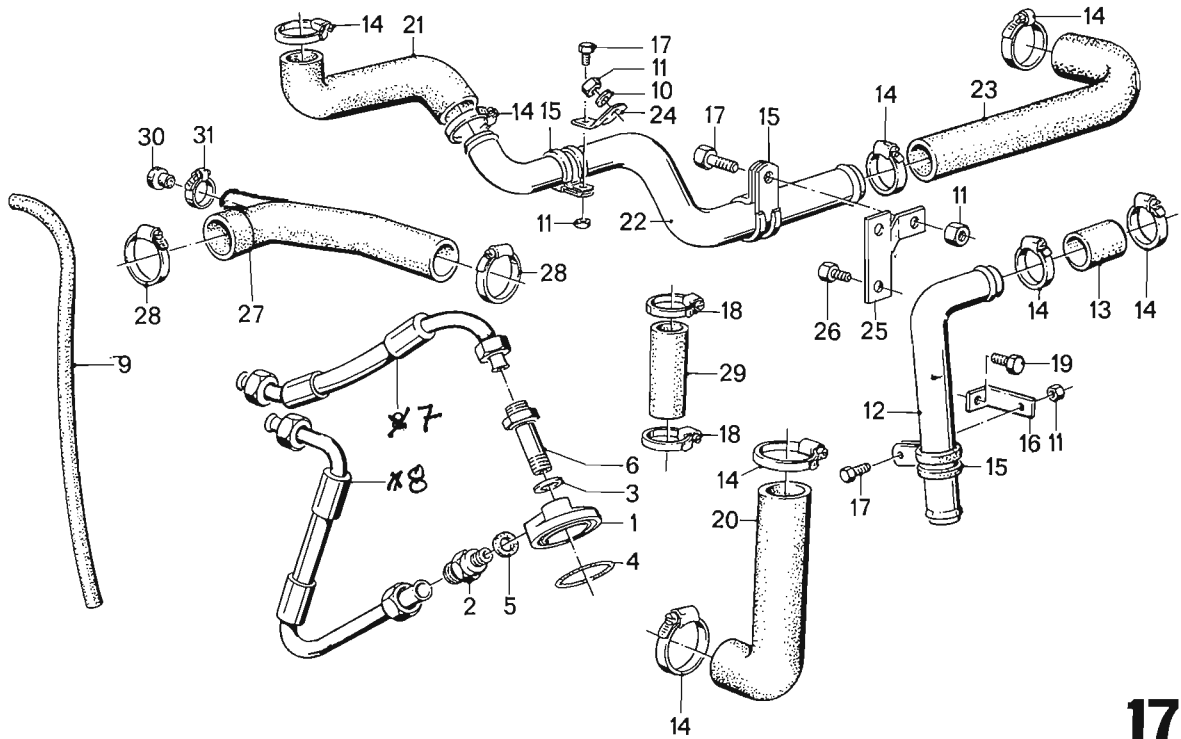

**17**  
**4/2**  
D 150/190/530/636  
4/86

<b>17</b> <b>4/2</b>		4/86		D 150	D 190	D 530	D 636	
Nr.	Teile-Nummer	Symbol	Benennung					Bemerkung
28	11 531 328 048		Ø 40–80 Schelle / Clamp / Collier / Klämma / Fascetta	2	2	2	2	
29	17 121 331 161		Krümmen / Elbow / Coude / Krök / Gomito	1	1	1	1	
30	17 121 761 354		Stopfen / Plug / Bouchon / Plugg / Tappo	1	1	1	1	
31	11 531 326 638		16–25 Schelle / Clamp / Collier / Klämma / Fascetta	1	1			

- a) Nur Verwendbar bei neuem Luftfilter / Only to be used with new air filter / Utilisable uniquement pour nouveaux filtre à air / Användbar bara vid nytt luftfilter / Utilizzabile solo a filtro selettivo nuovo  
 b) Nur für Z-Antrieb / For gear drive only / Uniquement pour Commande per engrènement / Bara för Kugghjulsdrivning / Solo comando per ingranaggi

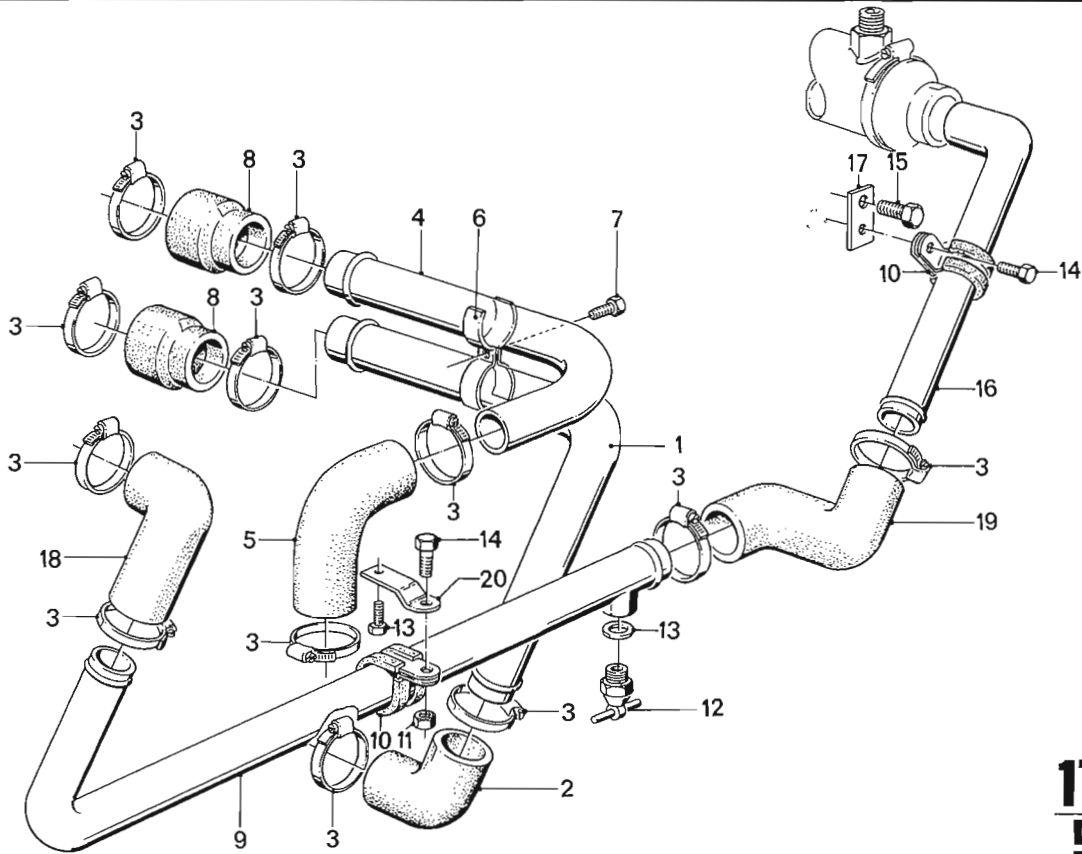

**17**  
**5**

D 150/190/530/636  
4/86

17 5		4/86										
Nr.	Teile-Nummer	Symbol	Benennung	D 150	D 190	D 530	D 636	Bemerkung				
1	17 12 1761 119		Seewasserrohr / Sea water pipe / Tube à eau de mer / Havsvattenrör / Tubo acqua di mare			1	1	1				
2	17 12 1761 120		Krümmen / Elbow / Coude / Krök / Gomito			1	1	1				
3	11 53 1326 639		32-50 Schelle / Clamp / Collier / Klämma / Fascetta			14	20	20				
4	17 12 1761 124		Seewasserrohr / Sea water pipe / Tube à eau de mer / Havsvattenrör / Tubo acqua di mare			1	1	1				
5	17 12 1761 125		Krümmen / Elbow / Coude / Krök / Gomito			1	1	1				
6	17 12 1761 122		Schelle / Clamp / Collier / Klämma / Fascetta			2	2	2				
7	07 11 9915 039		6 KT SHR M 6 × 14			1	1	1				
8	17 12 1761 121		Schlauchstutzen / Hose nozzle / Raccord de tuyau / Anschlussstück für slang / Raccordo per tubo flessibile			2	2	2				
9	a 17 12 1761 586		Seewasserrohr / Sea water pipe / Tube à eau de mer / Havsvattenrör / Tubo acqua di mare			1	1	1				
	a 17 12 1763 719		dito				1					
10	17 12 1331 113		Ø 29 Rohrschelle / Pipe clamp / Bride de tuyau / Rörklämma / Fascetta di tubo			3	2	4				
11	07 11 9922 087		6 KTMUM 8			2	2	2				
12	17 12 1763 335		1/4" Abfließhahn / Drain cock / Robinet de vidange / Utløpskran / Rubinetto di scarico			1	1	1				
13	07 11 9913 483		6 KT SHR M 6 × 25			2	2	2				
14	07 11 9913 624		6 KT SHR M 8 × 16			3	2	3				
15	07 11 9913 815		6 KT SHR M 10 × 16			1	1	1				
16	a 17 12 1761 585		Seewasserrohr / Sea water pipe / Tube à eau de mer / Havsvattenrör / Tubo acqua di mare			1	1	1				
17	17 12 1761 588		Halteblech / Retaining plate / Tôle de retenue / Fästplåt / Lamiere di sostegno			1	1	1				
18	17 12 1761 583		Krümmen / Elbow / Coude / Krök / Gomito			1	1	1				
19	17 12 1761 584		dito			1	1	1				
20	17 12 1761 589		Halte winkel / Support angle / Corniere d'appui / Winkelstöd			2	2	2				

a) Nur bei Wendegetriebe / For reversing gearbox only / Uniquement pour réducteur – inverseur / Bara för backväxel / Solo per cambio ad inversione di marcia

www.v12-engineering.com

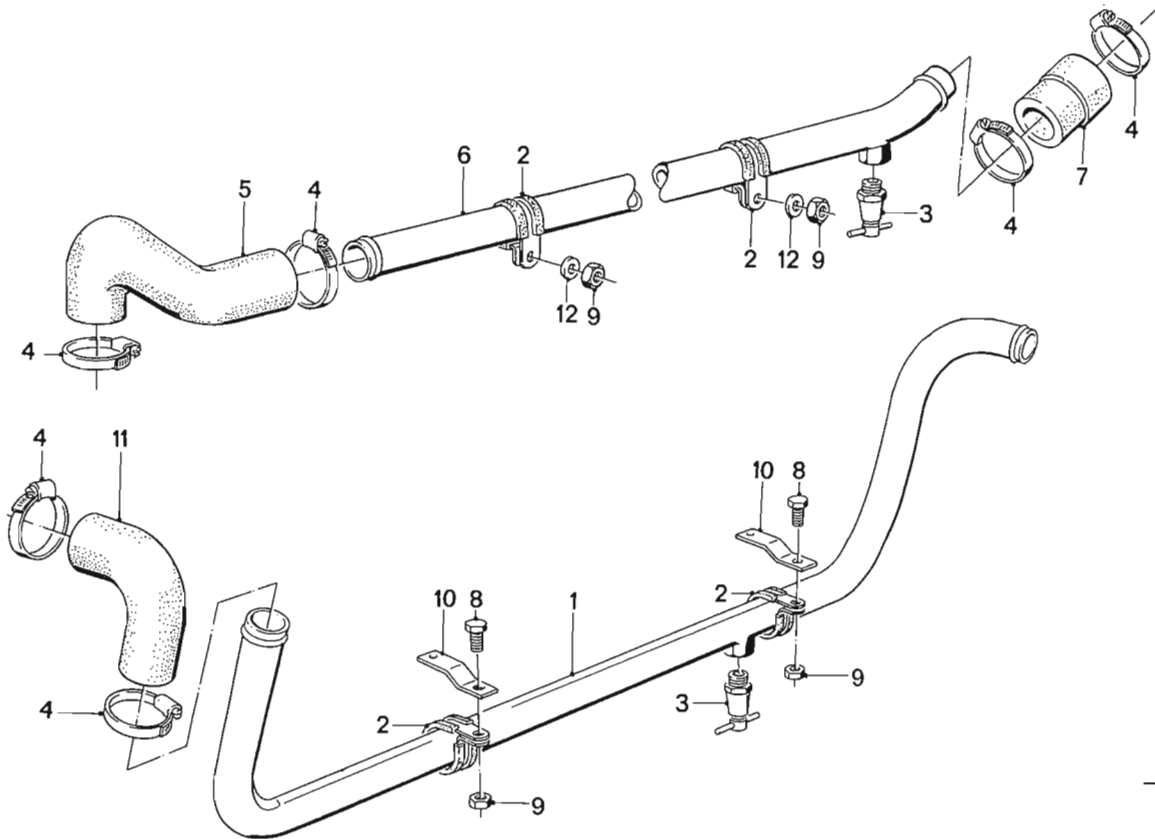

**17**  
**6**

D 530/636  
4/86

17 6		4/86							
Nr.	Teile-Nummer	Symbol	Benennung	D 150	D 190	D 530	D 636	Bemerkung	
1	a 17 12 1763 504		Seewasserrohr / Sea water pipe / Tube à eau de mer / Havsvattenrör / Tubo acqua di mare				1		
	a 17 12 1763 810		dito			1			
2	17 12 1 331 113		Ø 29 Rohrschelle / Pipe clamp / Bride de tuyau / Rörklämma / Fascetta di tubo			4	4		
3	17 12 1763 335		1/4" Abflßhahn / Drain cock / Robinet de vidange / Utloppskran / Rubinetto di scarico			2	2		
4	1153 1326 639		32-50 Schelle / Clamp / Collier / Klämme / Fascetta			6	6		
5	17 12 1763 230		Krümmer / Elbow / Coude / Krök / Gomito			1	1		
6	17 12 1763 229		Seewasserrohr / Sea water pipe / Tube à eau de mer / Havsvattenrör / Tubo acqua di mare				1		
	17 12 1763 722		dito			1			
7	17 12 1763 231		Schlauchstutzen / Hose nozzle / Raccord de tuyau / Anslutningsstycke for slang / Raccordo per tubo flessibile			1	1		
8	07 119913624		6KT SHR M8 x 16				2		
9	07 119922087		6KT MU M8				2		
10	17 12 1761 589		Haltewinkel / Support angle / Corniere d'appui / Vinkelstöd / Squadra de sostegno			2	2		
11	17 12 1761 583		Krümmer / Elbow / Coude / Krök / Gomito		1	1	1		
12	07 119931067		8,4 Scheibe / Washer / Rondelle / Bricka / Rondella				2		

a) Nur für Z-Antrieb / For gear drive only / Uniquement pour Commande per engrenage / Bara för Kugghjuldrivning / Solo comando per ingranaggi



Seewasserpumpe – Johnson  
 Sea water pump – Johnson  
 Pompe à eau de mer – Johnson  
 Havsvattenpump – Johnson  
 Pompa completa acqua marina – Johnson

BMW D 150 / D 190 / D 530 / D 636

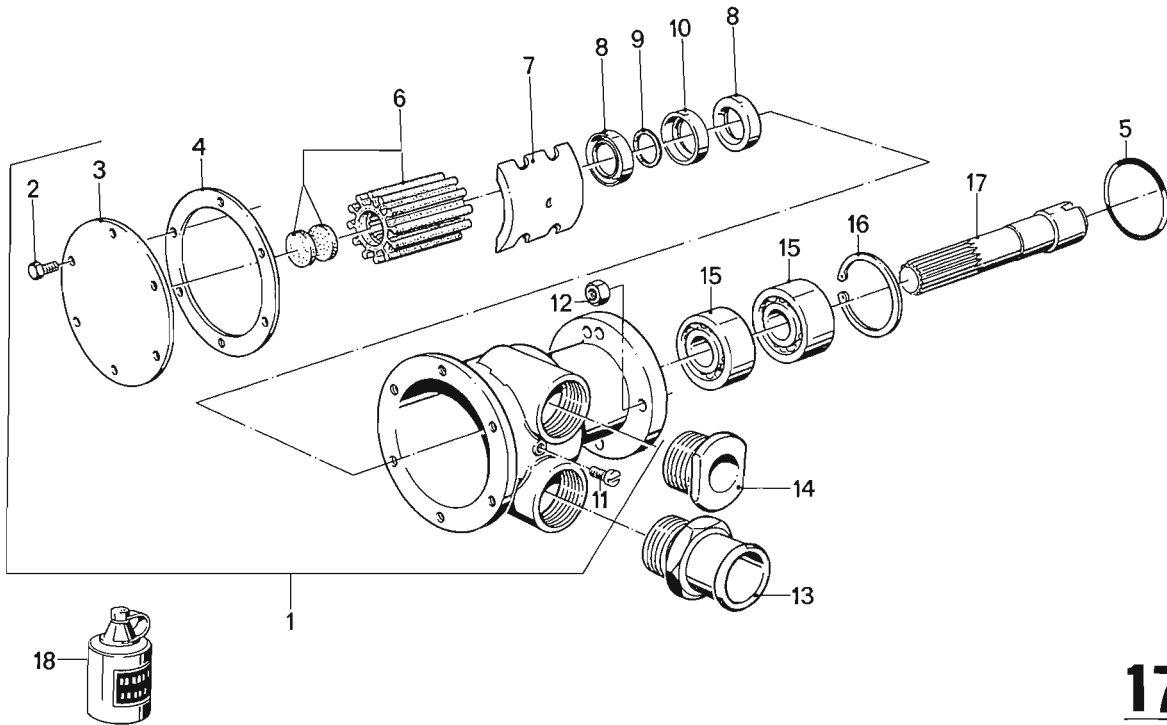

17  
7

D 150/D 190/D 636  
4/86

17 7		4/86							
Nr.	Teile-Nummer	Symbol	Benennung	D 150	D 190	D 530	D 636	Bemerkung	
1	17 111 331 196		kpI. Seewasserpumpe / Sea water pump / Pompe à eau de mer / Havsvattenpump / Pompa completa acqua marina	1	1	1	1		
2	17 111 333 847		LIN SHR M 5 × 8	6	6	6	6		
3	17 111 328 301		Deckel / Cover / Couvercle / Lock / Coperchio	1	1	1	1		
4	17 111 328 312		Dichtung / Gasket / Garniture / Packing / Guarnizione	1	1	1	1		
5	17 111 333 850		O-Ring / O-ring / Joint torique / O-ring / Anello-O	1	1	1	1		
6	17 111 328 126		Impeller / Impeller / Roue de pompe / Pomphjul / Impeller	1	1	1	1		
7	17 111 328 302		Kamm / Comb / Peigne / Kam / Pettine	1	1	1	1		
8	17 111 328 307		Wellendichtring / Shaft seal / Bague d'étanchéité radiale / Tätningsring axel / Anello di tenuta	2	2	2	2		
9	17 111 328 308		O-Ring / O-ring / Joint torique / O-ring / Anello-O	1	1	1	1		
10	17 111 330 113		Stützring / Support ring / Anneau d'appui / Stödtring / Anello di sostegno	1	1	1	1		
11	17 111 333 848		SHR	1	1	1	1		
12	07 119 922 058		6 KT M U M 6	4	4	4	4		
13	17 111 761 273		Schraubstutzen / Threaded socket / Raccord fileté / Skruvmuff / Bocchettone filettato	1	2	2	2		
14	17 111 326 537		dito	1					
15	17 111 333 849		Kugellager / Ball Bearing / Roulement à billes / Kullager / Cuscinetto a sfere	2	2	2	2		
16	17 111 328 310		Seegerring / Circlip / Circlip / Låsring / Anello Seger	1	1	1	1		
17	17 111 331 259		Welle / Shaft / Arbre / Axel / Albero	1	1	1	1		
18	07 589 056 979		Dichtmasse / Sealing compound / Matière cutante / Tätningsmaterial / Massa di tenuta		X	X	X		

V12 Engineering  
 Bcx 50, Ontario, Canada POX 1C0  
[www.bmwmarine.net](http://www.bmwmarine.net)

V12 Engineering  
 www.bitiv.com

Seewasserpumpe – Jabsco  
 Sea water pump – Jabsco  
 Pompe à eau de mer – Jabsco  
 Havsvattenpump – Jabsco  
 Pompa completa acqua marina – Jabsco

BMW D 150 / D 190 / D 530 / D 636

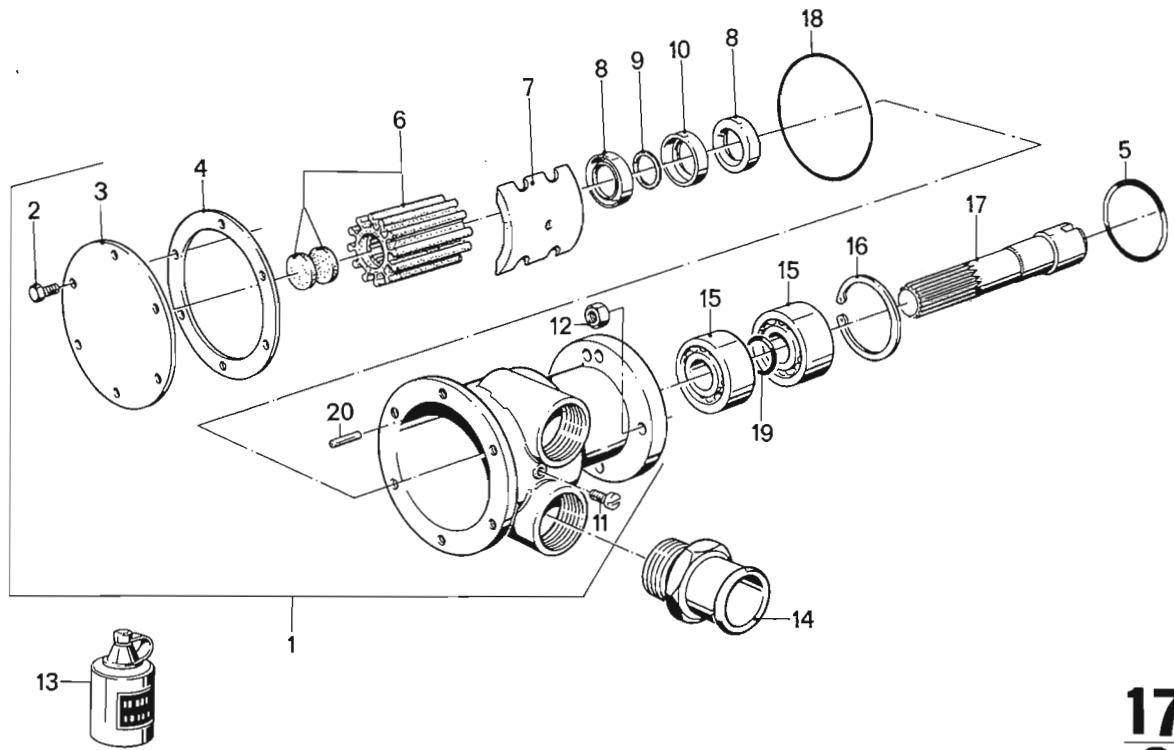

**17**  
**8**  
 D 530  
 4/86

17 8		4/86									
Nr.	Teile-Nummer	Symbol	Benennung	D 150	D 190	D 530	D 636	Bemerkung			
1	17 11 1 332 533		kpl. Seewasserpumpe / Sea water pump / Pompe à eau de mer / Havsvattenpump / Pompa completa acqua marina			1					
2	17 11 1 332 608		LIN SHR M 5 x 8		6						
3	17 11 1 332 607		Deckel / Cover / Couvercle / Lock / Coperchio		1						
4	17 11 1 332 606		Dichtung / Gasket / Garniture / Packing / Guarnizione		1						
5	17 11 1 333 850		O-Ring / O-ring / Joint torique / O-ring / Anello-O		1	1					
6	17 11 1 332 602		Impeller / Impeller / Roue de pompe / Pomphjul / Impeller		1						
7	17 11 1 332 603		Kamm / Comb / Peigne / Kam / Pettine		1						
8	17 11 1 332 600		Wellendichtring / Shaft seal / Bague d'étanchéité radiale / Tätningring axel / Anello di tenuta		2						
9	17 11 1 332 598		O-Ring / O-ring / Joint torique / O-ring / Anello-O		1						
10	17 11 1 332 599		Abstandhalter / Spreader / Ecarteur / Avståndshållare / Distanziale		1						
11	17 11 1 332 604		SHR		1						
12	07 11 9 922 058		6 KT MUM 6		4	4					
13	07 58 9 056 979		Dichtmasse / Sealing compound / Matière cutante / Tätningmaterial Massa di tenuta		1	1					
14	17 11 1 761 273		dito		2	2					
15	17 11 1 332 597		Kugellager / Ball Bearing / Roulement à billes / Kullager / Cuscinetto a sfere		2						
16	17 11 1 332 595		Sicherungsring / Snap ring / Circlip / Låsring / Anello di sicurezza		1						
17	17 11 1 332 593		Welle / Shaft / Arbre / Axel / Albero		1						
18	17 11 1 332 601		Anlaufscheibe / Thrust washer / Rondelle d'entraînement / Passbricka / Rosetta di arresto		1						
19	17 11 1 332 596		Abstandstück / Spacer / Entretoise / Distanstycke / Distanziatore		1						
20	17 11 1 332 620		Stift / Pin / Goupille / Pinne / Perno		1						

V12 Engineering  
 Box 50, Ontario, Canada POX 1C0  
[www.bmwmarine.net](http://www.bmwmarine.net)

V12 Engineering  
[www.bmwmarine.com](http://www.bmwmarine.com)

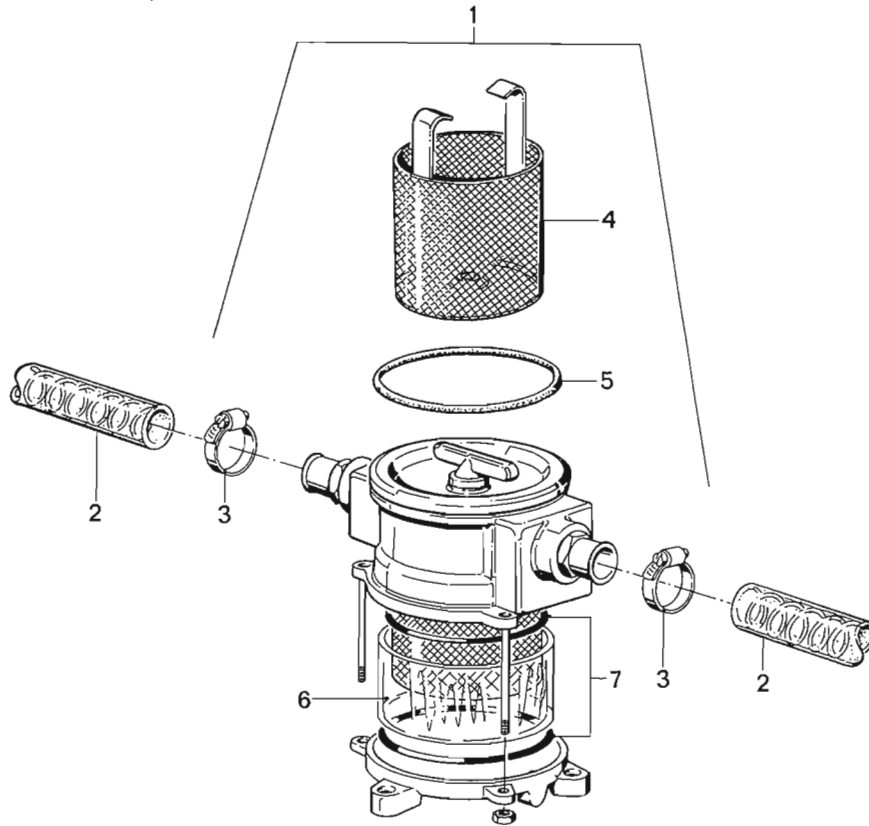

**17**  
**9**

D 150/190/530/636  
4/86

<b>17</b> <b>9</b>		4/86									
Nr.	Teile-Nummer	Symbol	Benennung	D 150	D 190	D 530	D 636	Bemerkung			
1	a 17 111 1331 257		kpl. Seewasserfilter / Seawater filter / Filtre à eau de mer / Havsvattensfilter / Filtro acqua di mare	1	1	1	1				
2	17 111 1331 258		Schlauch / Hose / Tuyau / Slang / Tubo flessibile	2	2	2	2				
3	11 531 1326 523		Ø 25-40 Schelle / Clamp / Collier / Klämme / Fascetta	4	4	4	4				
4	17 111 1333 878		Einsatz / Element / Élément amovible / Insats / Elemento amovibile	1	1	1	1				
5	17 111 1333 880		O-Ring / O-ring / Joint torique / O-ring / Anello-O	1	1	1	1				
6	17 111 1761 107		Sichtzylinder / Inspection cylinder / Cylindre d'inspection / Siktzylinder / Cilindro visivo	1	1	1	1				
7	17 111 1761 108		Dichtung / Seal / Garniture / Packning / Guarnizione	2	2	2	2				

a) 1 1/4" Anschluß / Connecting / Raccordement / Kopplung / Attacco

Kupplungsglocke  
Clutch bell  
Cloche d'empryage  
Kopplingsglocka  
Campana interna della frizione

BMW D 150 / D 190 / D 530 / D 636

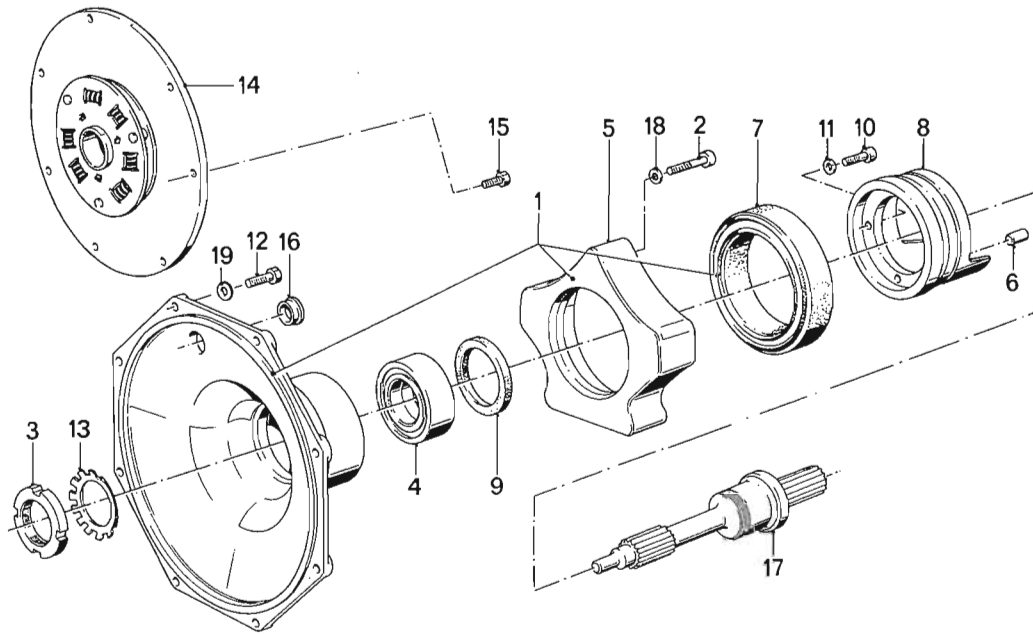

V12 Engineering  
Box 50, Ontario, Canada POX 1C0  
www.bmwmarine.net

21  
1

D 150/190/530/636  
4/86

21 1		4/86										
Nr.	Teile-Nummer	Symbol	Benennung	D 150	D 190	D 530	D 636	Bemerkung				
1	11 81 1 761 279		kpl. Kupplungsglocke / Clutch bell / Cloche d'embrayage / Kopplingsglocka / Campana interna della frizione	1	1	1	1					
2	11 81 1 326 478		6 KT SHR M 10 x 45	5	5		5					
3	07 11 9 926 243		Nutmutter / Grooved nut / Ecrou cannelé / Ringmutter med spår / Ghiera	1	1	1	1					
4	11 81 1 326 533		Schrägkugellager / Angular ball bearing / Roulement à billes à contact oblique / Kullager för axiellt och radiellt tryck / Cuscinetto a sfera obliquo	1	1	1	1					
5	11 81 1 330 557		Lagerflansch / Bearing flange / Bride de palier / Lagerfläns / Fiangia del cuscinetto	1	1	1	1					
6	11 81 1 326 474		Zentrierbolzen / Centering bolt / Boulon de centrage / Centeringsbult / Bullone di centraggio	2	2	2	2					
7	11 81 1 326 813		Ringpuffer / Ring buffer / Butée annulaire / Dämpkudde / Tampone annulare	1	1	1	1					
8	11 81 1 328 821		Spannring / Clampring / Collier tendeur / Spannring / Anello tenditore	1	1	1	1					
9	11 81 1 328 858		Radialwellendichtring / Radial shaft sealing ring / Joint d'arbre / Radiell axeltätning / Anello di tenuta albero radiale	1	1	1	1					
10	07 11 9 919 689		ZYL SHR M 8 x 25	4	4	4	4					
11	07 11 9 931 661		8,4 Scheibe / Washer / Rondelle / Bricka / Rondella	4	4	4	4					
12	07 11 9 913 843		6 KT SHR M 10 x 35	8	8	7	8					
13	07 11 9 935 942		Sicherungsblech / Lock plate / Tôle de frein / Låsbricka / Lamiera di sicurezza	1	1	1	1					
14	a 21 21 1 761 008		Elastische Kupplung / Flexible coupling / Accouplement élastique / Elastik koppling / Giunto elastico	1	1	1	1					
	b 21 21 1 761 771		dito	1	1		1					
15	07 11 9 913 624		6 KT SHR M 8 x 16	6	6	6	6					
16	11 81 1 329 348		Verschlußstopfen / Plug / Bouchon / Plug / Tappo di chiusura	1	1	1	1					
17	26 11 1 328 678		Antriebswelle / Drive shaft / Arbre de commande / Motoraxel Albero primario	1	1							
	26 11 1 332 270		dito			1	1					
18	11 81 1 326 477		Unterlegscheibe / Washer / Rondelle / Underlägsbricka / Disco d'appoggiad spår	5	5	5	5					
19	07 11 9 931 076		A 10,5 Scheibe / Washer / Rondelle / Bricka / Rondella			7						

a) Nur für Z-Antrieb / For gear drive only / Uniquement pour Commande per engrènement / Bara för Kugghjuldrivning / Solo per comando per ingranaggi  
b) Nur für Wendegeräte / For reversing gearbox only / Uniquement pour réducteur-inverseur / Bara för backväxel / Solo per cambio ad inversione di marcia

V12 Engineering  
www.bmwmarine.com



Z-Antrieb  
 Stern drive  
 Commande per engranage  
 Kugghjulsdrivning  
 Comando per ingranaggi

BMW D 150 / D 190 / D 530 / D 636

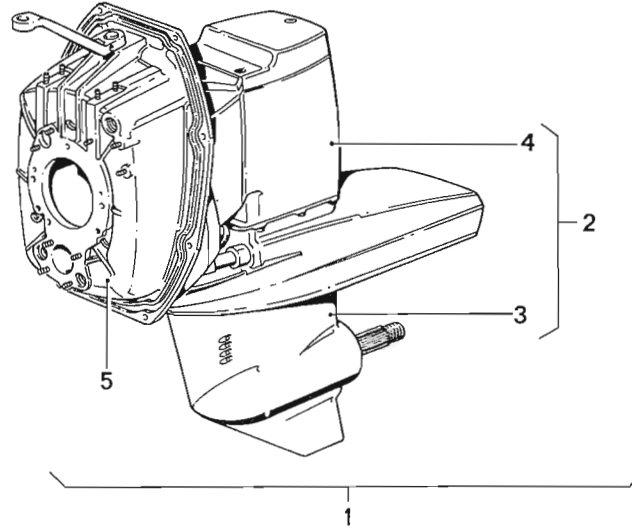

**27**  
**1**  
 D 530/636  
 4/86

<b>27</b> <b>1</b>		4/86								
Nr.	Teile-Nummer	Symbol	Benennung	D 150 Mk I	D 150 Mk II	D 190 Mk II	D 530	D 636	Bemerkung	
1	27 62 1 332 282		kpl. 1,61 Z-Antrieb / Stern drive / Commande per engranage / Kugghjulsdrivning / Comando per ingranaggi				1	1		
2	27 62 1 332 283		i = 1,61 Getriebe / Gearbox / Boîte à vitesse / Växel / Gruppo propulsore				1	1		
3	27 62 1 330 855		kpl. i = 1,61 Z-Antrieb-Unterteil / Stern drive lower part / Commande per engranage partier intérieure / Kugghjulsdrivning underdel / Parte inferiore comando ingranaggi				1	1		
4	27 62 1 332 394		kpl. Z-Antrieb-Oberteil / Stern drive top part / Commande per engranage partier supérieure / Kugghjulsdrivning överdel / Parte superiore comando ingranaggi				1	1		
5	27 62 1 332 366		kpl. Getriebeaufhängung / Gearbox suspension / Suspension de commande / Växelupphängning / Sospensione del gruppo propulsore					1		
	27 62 1 332 720		dito					1		

V12 Engineering  
 www.bmwmarine.com

Z-Antrieb  
 Stern drive  
 Comande per engrnage  
 Kugghjulsdrivning  
 Comando per ingranaggi

BMW D 150 / D 190

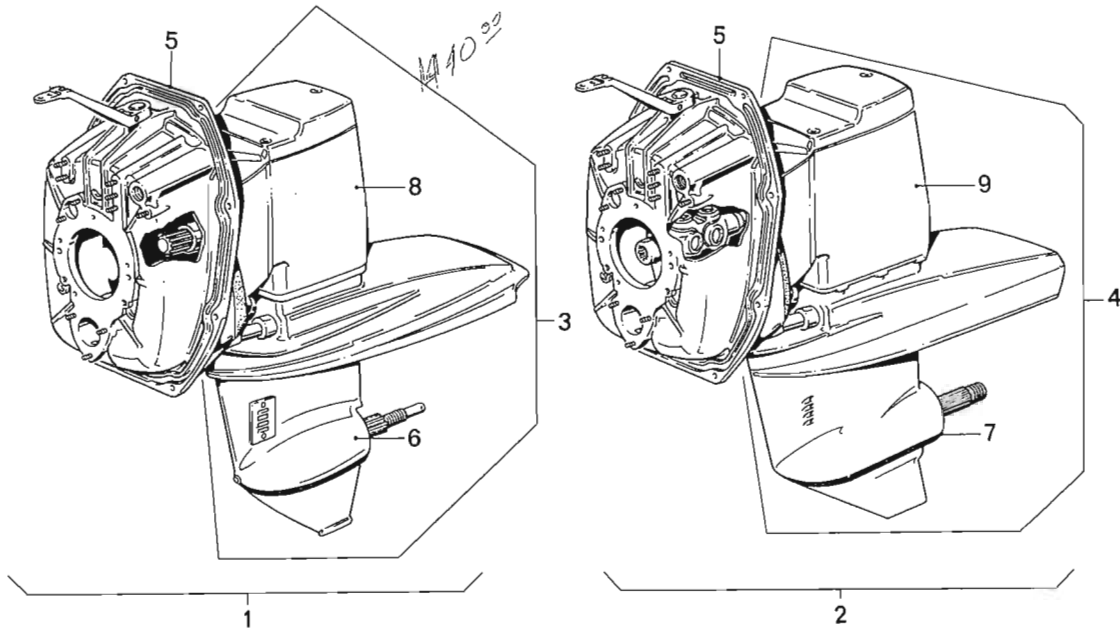

**27**  
**2**

D 150/D 190/  
4/86

<b>27</b> <b>2</b>		4/86				D 150 Mk I	D 150 Mk II	D 190 Mk II			Bemerkung
Nr.	Teile-Nummer	Symbol	Benennung								
1	a 27 62 1 330 932		kpl. i = 1,61 Z-Antrieb / Stern drive / Comande per engrnage / Kugghjulsdrivning / Comando per ingranaggi			1					
2	b 27 62 1 330 929		dito				1	1			
3	a 27 62 1 330 845		i = 1,61 Getriebe / Gearbox / Boîte à vitesse / Växel / Gruppo propulsore			1					
4	b 27 62 1 330 849		dito				1	1			
5	27 62 1 330 977		kpl. Getriebeaufhängung / Gearbox suspension / Suspension de commande / Växelupphängning / Sospensione del gruppo propulsore				1	1			
6	a 27 62 1 330 859		kpl. i = 1,61 Z-Antrieb-Unterteil / Stern drive lower part / Comande partier inférieure / Växellade underdel / Parte inferiore comando ingranaggi			1					
7	b 27 62 1 330 855		dito				1	1			
8	a 27 62 1 330 840		kpl. 1:50 Z-Antrieb-Oberteil / Stern drive top part / Comande partier supérieur / Växellada överdel / Parte superiore comando ingranaggi			1					
9	b 27 62 1 330 846		dito - 1:100				1	1			

a) — Getriebe Nr. 7999  
 b) Getriebe Nr. — 8000

V12 Engineering

www.bmwmarine.com

Spiegelplatte  
 Mirrorplate  
 Plaque à miroir  
 Spegelplat  
 Piastra a specchio

BMW D 150 / D 190 / D 530 / D 636

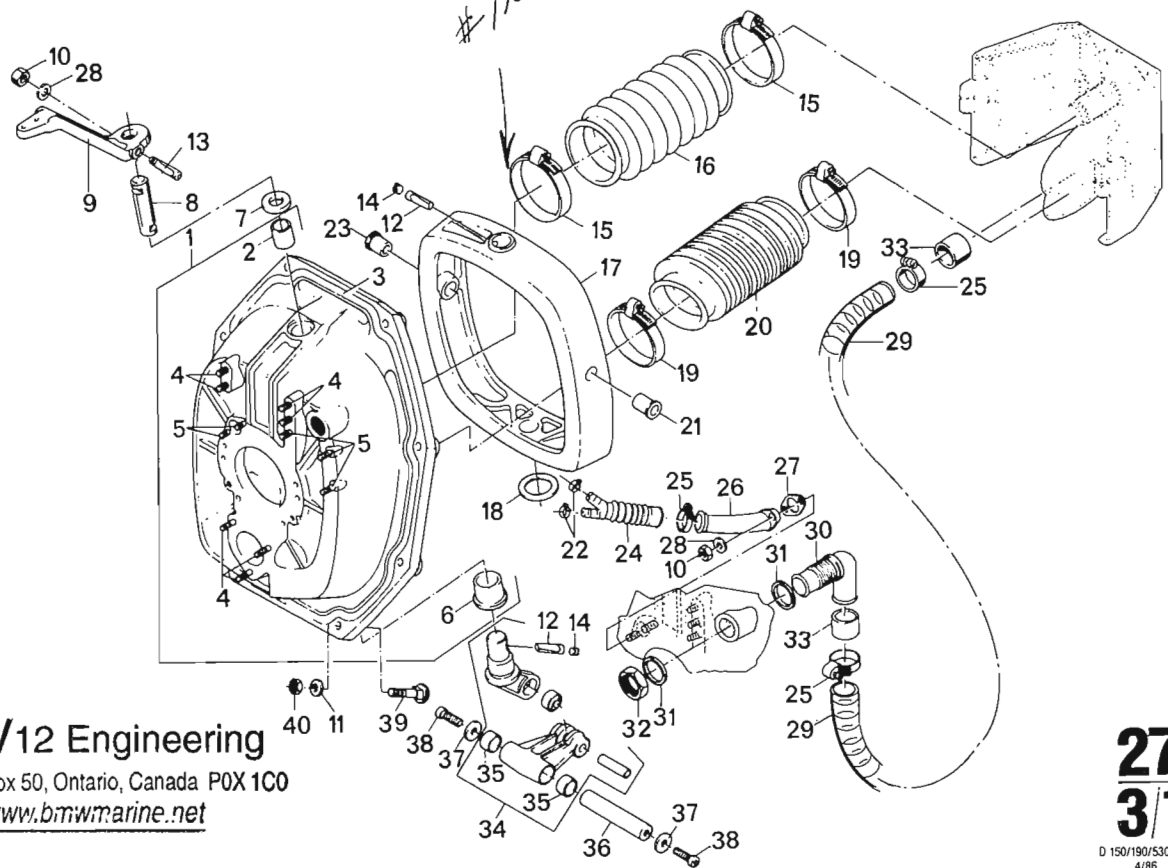

V12 Engineering

Box 50, Ontario, Canada P0X 1C0

[www.bmwmarine.net](http://www.bmwmarine.net)

27  
3/1

D 150/190/530/636  
4/86

27 3/1		4/86								
Nr.	Teile-Nummer	Symbol	Benennung	D 150 Mk I	D 150 Mk II	D 190 Mk II	D 530	D 636	Bemerkung	
1	27 62 1 330 064		Spiegelplatte / Mirrorplate / Plaque à miroir / Spegelplat / Piastra a specchio	1	1	1				
2	27 62 1 328 263		Lagerbuchse / Bearing bush / Coussinet / Lagerbussning / Boccola di supporto	1	1	1	1	1		
3	27 62 1 328 418		Ø 10 Rundschnurring / String ring / Anneau à corde / Snörering / Anello a sezione toric.	1	1	1	1	1	1,6 m	
4	07 11 9 908 355		STI SHR M 8 × 22	7	7	7				
5	07 11 9 909 054		STI SHR M 8 × 16	5	5	5				
6	27 62 1 328 262		Lagerbuchse / Bearing bush / Coussinet / Lagerbussning / Boccola di supporto	1	1	1		1		
7	27 62 1 328 416		DTRG	1	1	1	1	1		
8	27 62 1 328 596		Lenkbolzen / Steering bolt / Boulon de direction / Styrbult / Perno di sterzo	1	1	1	1	1		
9	27 62 1 328 590		Lenkhebel / Steering arm / Barre franche de direction / Styrarm / Leva sul fuso a snodo	1	1	1				
10	07 11 9 922 073		6 KT MU M 8	3	3	3	3	3		
11	07 11 9 936 442		Ø 13 Scheibe / Washer / Rondelle / Bricka / Rondella	8	8	8	8	8		
12	27 62 1 328 275		Spannstift / Spring dowel sleeve / Goupille de serrage / Spännstift / Perno tenditore di fissaggio	1	1	1	1	1		
13	27 62 1 328 595		dito	1	1	1	1	1		
14	27 62 1 328 419		GEW STIM 14 × 1,5	2	2	2	2	2		
15	27 62 1 332 143		110-130 Schlauchschelle / Hose clamp / Collier de flexible / Slangklämma / Collare per tubo flessibile	2	2	2	2	2		
16	27 62 1 328 259		Faltenbalg / Bellows / Accordéon / Veckad bälg / Soffietto	1	1	1	1	1		
17	27 62 1 330 065		Kardanring / Cardan ring / Anneau cardan / Kardanring / Anello cardanico	1	1	1	1	1		
18	27 62 1 328 273		Scheibe / Washer / Rondelle / Bricka / Rondella	1	1	1	1	1		
19	27 62 1 332 152		70-90 Schelle / Clamp / Collier / Klämma / Fascetta	2	2	2	2	2		
20	27 62 1 328 283		Faltenbalg / Bellows / Accordéon / Vackad bälg / Soffietto	1	1	1	1	1		
21	27 62 1 328 267		Lagerbuchse / Bearing bush / Coussinet / Lagerbussning / Boccola di supporto	1	1	1	1	1		
22	27 62 1 332 150		8-16 Schelle / Clamp / Collier / Klämma / Fascetta	2	2	2	2	2		

V12 Engineering  
www.bmwmarine.com



Spiegelplatte  
 Mirrorplate  
 Plaque à miroir  
 Spegelplat  
 Piastra a specchio

BMW D 150 / D 190 / D 530 / D 636

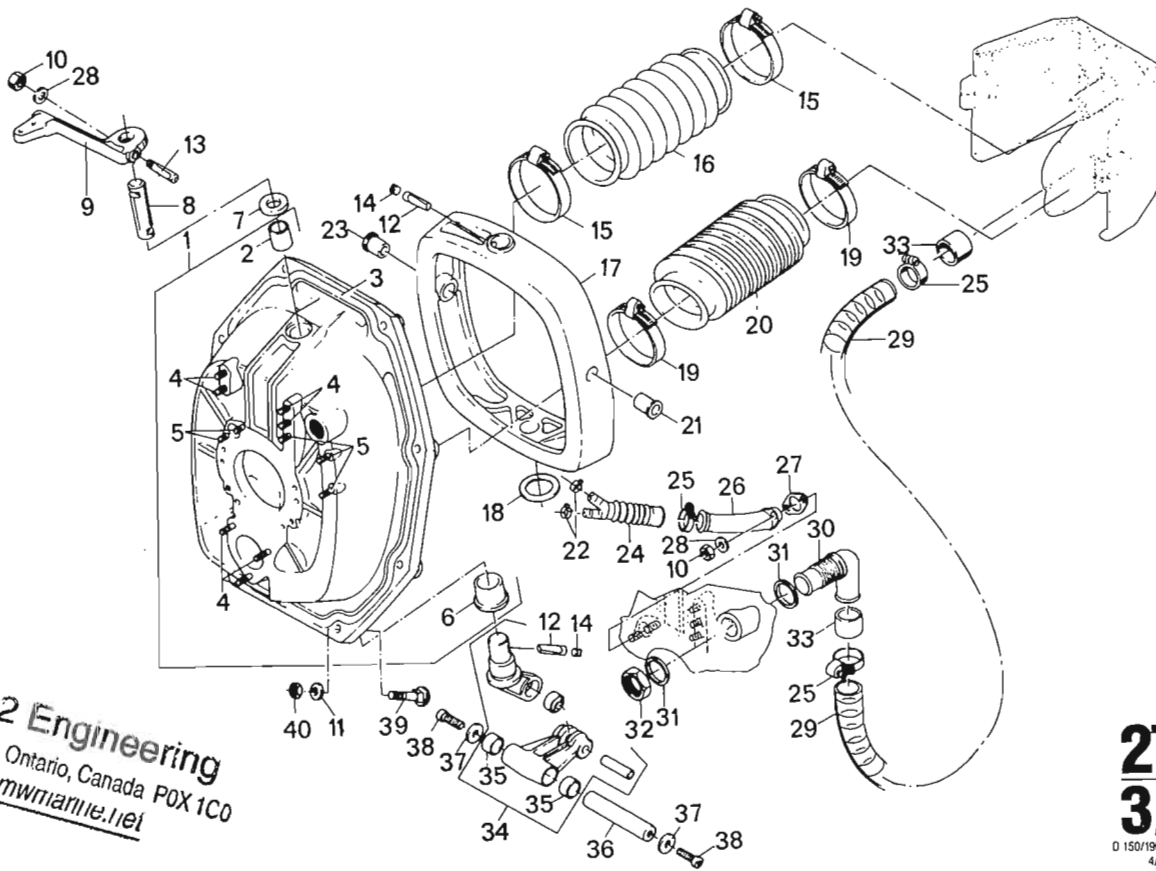

**27**  
**3/2**  
 D 150/190/530/636  
 4/86

V12 Engineering  
 Box 50, Ontario, Canada P0X 1C0  
 www.bmwmarine.net

27 3/2		4/86											
Nr.	Teile-Nummer	Symbol	Benennung	D 150 Mk I	D 150 Mk II	D 190 Mk II	D 530	D 636	Bemerkung				
23	27 62 1 328 835		Lagerbuchse / Bearing bush / Coussinet / Lagerbussning / Boccola di supporto	1	1	1	1	1					
24	27 62 1 328 281		Faltenbalg / Bellows / Accordéon / Vackad bälg / Soffietto	1	1	1	1	1					
25	27 62 1 332 151		25-40 Schelle / Clamp / Collier / Klämma / Fascetta	4	4	4	4	4					
26	27 62 1 328 282		Krümmmer / Elbow / Coude / Krök / Gomito	1	1	1	1	1					
27	07 11 9962 507		DTRG	1	1	1	1	1					
28	07 11 9932 084		A 8 Federscheibe / Spring washer / Rondelle élastique / Fjäderbricka / Rosetta elastica	3	3	3	3	3					
29	27 62 1 328 276		Wasserschlauch / Water hose / Flexible à eau / Vattenslang / Tubo flessibile p. acqua	1	1	1	1	1					
30	27 62 1 328 279		Wasserkrümmer / Water manifold / Raccord coudé à eau / Vattenkrök / Raccordo a gomito per acqua	1	1	1	1	1					
31	07 11 9963 468		DTRG	2	2	2	2	2					
32	27 62 1 328 260		6 KT MU	1	1	1	1	1					
33	27 62 1 330 382		Gummitülle / Rubber grommet / Douille en caoutch / Gummihatt / Boccola di gomma	2	2	2	2	2					
34	27 62 1 330 066		kpl. Gelenk / Knuckle / Articulation / Länk / Articolazione	1	1	1	1	1					
35	27 62 1 328 249		Buchse / Bushing / Douille / Bussning / Boccola	2	2	2	2	2					
36	27 62 1 328 277		Bolzen / Bolt / Boulon / Bult / Bullone	1	1	1	1	1					
37	07 11 9936 433		8,4 Scheibe / Washer / Rondelle / Bricka / Rondella	2	2	2	2	2					
38	07 11 9919 775		ZYL SHR M 8 x 25	2	2	2	2	2					
39	27 64 1 326 967		Flachrundsraube / Screw / Vis / Skruv / Vite a testa rotondapiatta	8	8	8	8	8					
40	07 11 9922 133		6 KT MU M 12	8	8	8	8	8					

www.bmwmarine.net

Trimmgeber – Idea  
 Trimmer – Idea  
 Transmetteur de compensation – Idea  
 Trimmgivare – Idea  
 Trasmettitore di compensazione – Idea

BMW D 150 / D 190

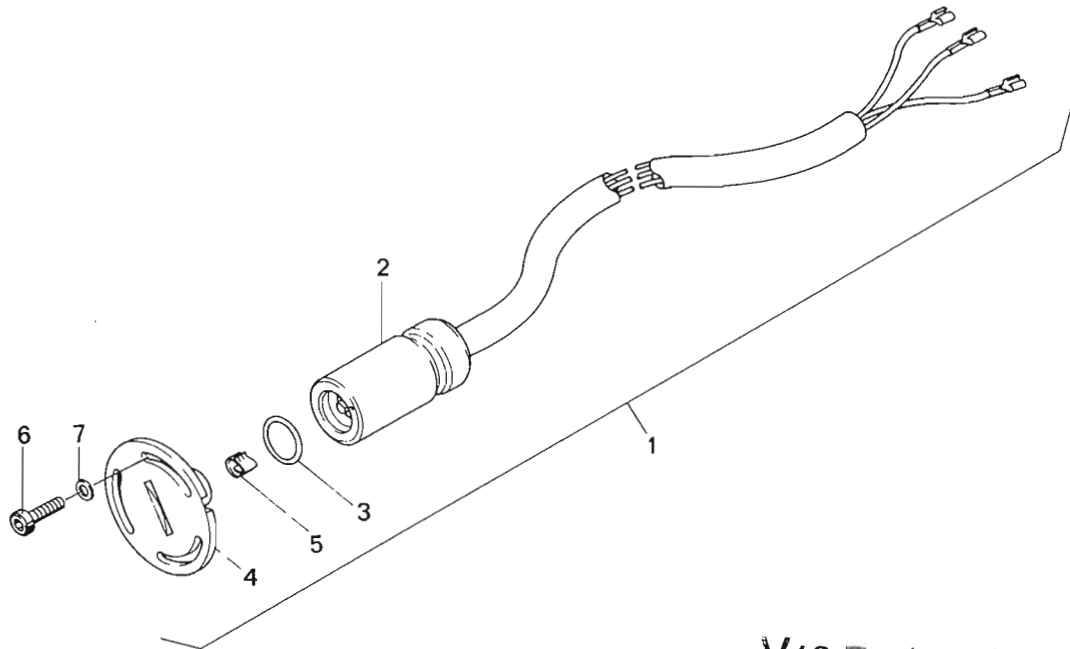

V12 Engineering  
 Box 50, Ontario, Canada P0X 1C0  
[www.bmwmarine.net](http://www.bmwmarine.net)

**27**  
**4**  
 D 150/D 190  
 4/86

<b>27</b> <b>4</b>		4/86																			
Nr.	Teile-Nummer	Symbol	Benennung	D 150 Mk I	D 150 Mk II	D 190 Mk II														Bemerkung	
1	a 27 62 1 328 882		kpl. Geber f. Trimmsteuerung / Trimmsteering pick-up / Transmetteur d'arrimage / Givare för trimstyrning / Trasmettitore per comando calibratura	1	1	1															
2	a 27 62 1 328 620		Geber / Pick-up / Transmetteur / Givare / Trasmettitore	1	1	1															
3	a 27 62 1 328 623		O-Ring / O-ring / Joint torique / O-ring / Anello-O	1	1	1															
4	a 27 62 1 328 624		Einstelldeckel / Adjust cover / Couvercle d'ajustement / Inställkåpa / Coperchio di registrazione	1	1	1															
5	a 27 62 1 328 621		Klammer / Clip / Crampon / Klämna / Grappa	1	1	1															
6	07 11 9907 666		LIN SHR M 4 x 12	3	3	3															
7	07 11 9931 633		4,3 Scheibe / Washer / Rondelle / Bricka / Rondella	3	3	3															

a) Nur für Idea-Instrumente / For Idea-instruments only / Uniquement pour Idea-instruments / Bara för Idea-instrument / Solo per strumenti – idea

V12 Engineering  
[www.bmwmarine.com](http://www.bmwmarine.com)

Spiegelplatte  
 Mirrorplate  
 Plaque à miroir  
 Spegelplat  
 Piastra a specchio

BMW D 150 / D 190 / D 530 / D 636

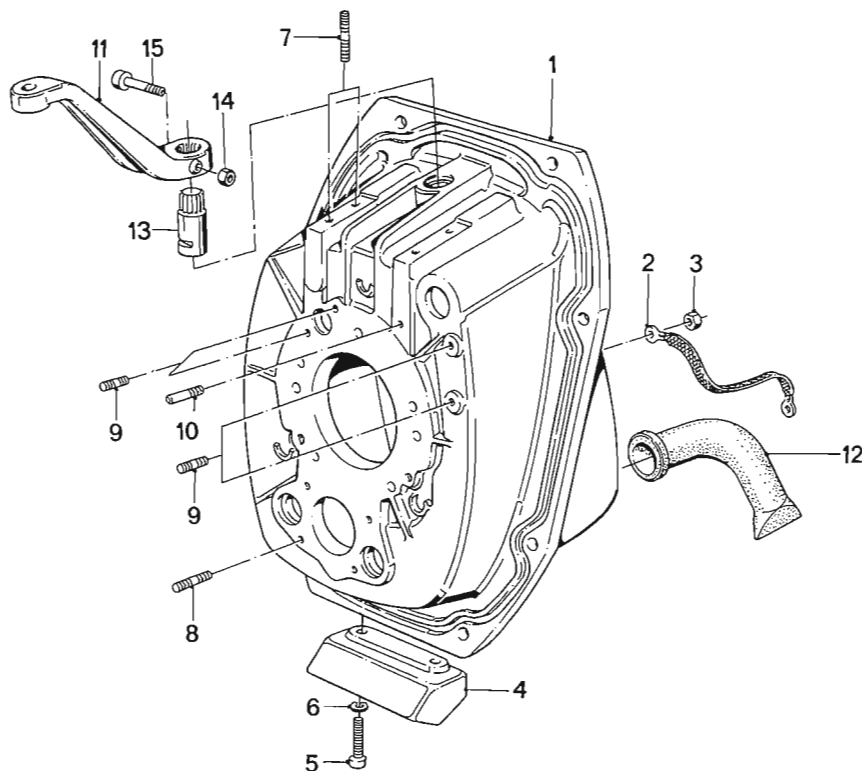

**27**  
**5**  
 0530/636  
 4/86

<b>27</b> <b>5</b>		4/86								
Nr.	Teile-Nummer	Symbol	Benennung	D 150 Mk I	D 150 Mk II	D 190 Mk II	D 530	D 636	Bemerkung	
1	27 62 1 332 393		Spiegelplatte / Mirror plate / Plaque à miroir / Spegelplat / Piastra a specchio				1	1		
2	27 62 1 334 313		Massekabel / Ground lead / Câblé de masse / Jordledningskabel / Cavo di massa				1	1		
3	07 11 9922 073		6 KT MU M 8				1	1		
4	27 62 1 332 299		Opferanode / Reactive anode / Anode consommable / Offeranod / Anodo anticorrosione				1	1		
5	07 11 9919 593		ZYL SHR M 8 x 30				2	2		
6	07 11 9932 084		A 8 Federscheibe / Spring washer / Rondelle elastique / Fjäderbricka / Rosetta elastica				2	2		
7	07 11 9908 400		STI SHR M 8 x 30				4	4		
8	07 11 9909 355		STI SHR M 8 x 20	7	7	7	4	4		
9	07 11 9909 054		STI SHR M 8 x 16	5	5	5	4	4		
10	07 11 9940 976		Gewindebolzen / Bolt / Boulon fileté / Gängad bult / Perno filettato				1	1		
11	27 62 1 332 307		Lenkhebel / Steering arm / Barre franche de direction / Styrarm / Leva sul fuso a snodo				1	1		
	27 62 1 332 680		dito				1	1		
12	11 62 1 332 296		Krümmer / Elbow / Coude / Krök / Gomito				2	2		
13	27 62 1 332 681		Lenkbolzen / Steering bolt / Boulon de direction / Styrbult / Perno di sterzo				1	1		
14	07 11 9922 420		6 KT MU M 8				1	1		
15	07 11 9919 747		ZYL SHR M 8 x 55				1	1		



V12 Engineering  
Box 50 Ontario, Canada POX 100  
www.bmwmarine.net

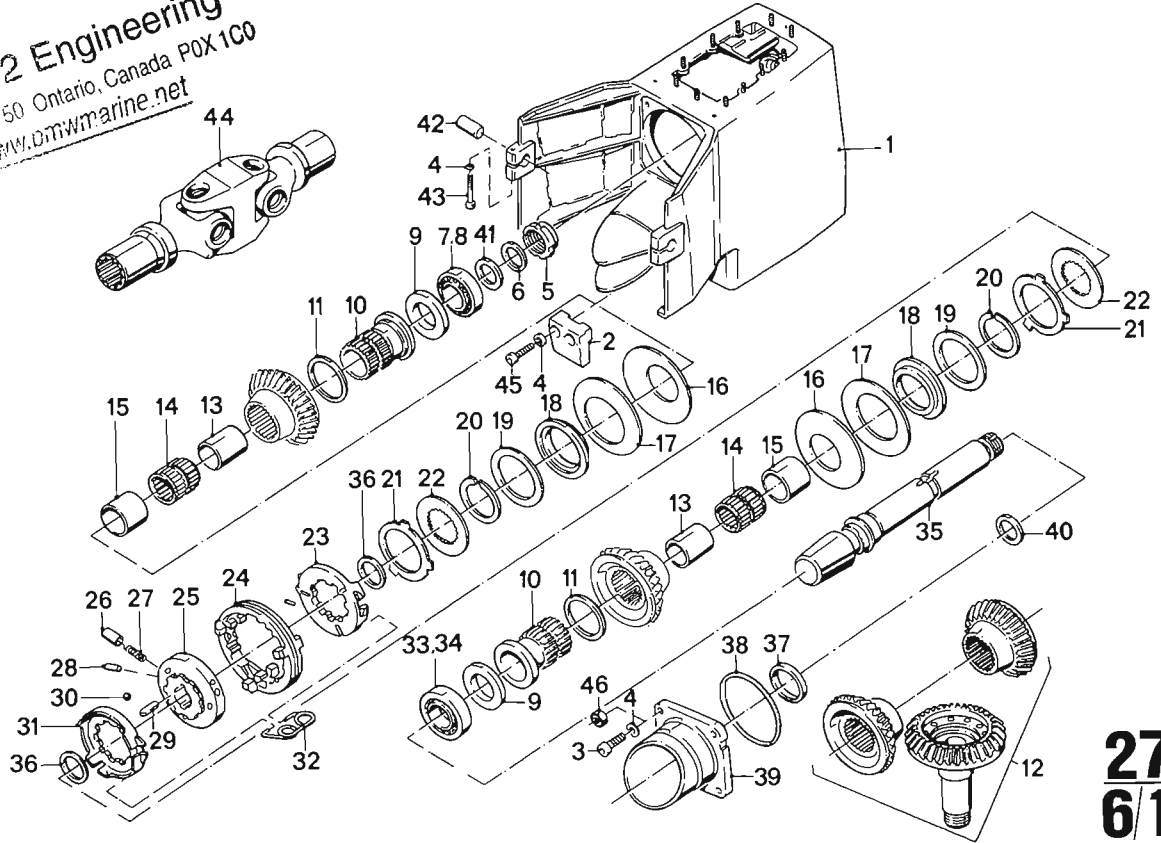

**27**  
**6/1**

D 150/190/530/636  
4/86

27 6/1		4/86										
Nr.	Teile-Nummer	Symbol	Benennung	D 150 Mk I	D 150 Mk II	D 190 Mk II	D 530	D 636	Bemerkung			
1	27 62 1 330 033		Gehäuse Oberteil / Housing top part / Carter partier supérieure / Husöverdel / Carter parte superiore	1								
	27 62 1 330 827		dito		1	1	1	1				
2	27 62 1 328 130		Opferanode / Reactive anode / Anode consommable / Offeranod / Anodo anticorrosione	1	1	1						
3	a 07 11 9919 632		ZYL SHR M 8 x 25	4	4							
4	07 11 9932 084		A 8 Federscheibe / Spring washer / Rondelle élastique / Fjäderbricka / Rosetta elastica	6	6	6	4	4				
5	27 62 1 328 173		Nutmutter / Grooved nut / Ecrou cannelé / Ringmutter med spår / Ghiera	1	1	1	1	1				
6	27 62 1 328 385		PA SHB	1	1	1	1	1				
7	27 62 1 328 389		Kegelrollenlager – Innenring / Tapered roller bearing – Inner ring / Roulement à rouleaux coniques – Anneau intérieur / Koniskt rullager – Innenring / Cusc. a rulli conici – Anello interno	1	1	1	1	1				
8	27 62 1 328 390		dito – Außenring / – Outer ring / – Anneau extérieur / – Yttering / – Anello esterno	1	1	1	1	1				
9	27 62 1 328 187		Anlaufscheibe / Thrust washer / Rondelle d'entraînement / Passbricka / Rosetta di arresto	2	2	2	2	2				
10	27 62 1 328 199		Laufbuchse / Bushing / Douille / Bussning / Canna	2	2	2	2	2				
11	27 62 1 328 190		+ 1,3 Einstellscheibe / Flatwasher / Rondelle / Bricka / Disco di registrazione	X	X	X	X	X				
	27 62 1 328 191		+ 1,4	X	X	X	X	X				
	27 62 1 328 192		+ 1,5	X	X	X	X	X				
	27 62 1 328 193		+ 1,6	X	X	X	X	X				
	27 62 1 328 194		+ 1,7	X	X	X	X	X				
	27 62 1 328 195		+ 1,8	X	X	X	X	X				
	27 62 1 328 378		+ 1,9	X	X	X	X	X				
	27 62 1 328 379		+ 2,0	X	X	X	X	X				
	27 62 1 328 711		+ 2,1	X	X	X	X	X				
	27 62 1 328 712		+ 2,2	X	X	X	X	X				
12	27 62 1 328 183		Radsatz / Wheelset / Train de roues / Hjulsats / Treno d. ingranaggio	1	1	1	1	1				
13	27 62 1 328 181		Nadellager – Innenring / Needle roller bearing inner ring / Bague intérieure de roulement à aiguilles / Nallager – innerring / Anello interno cuscinetto ad aghi	2	2	2	2	2				

a) → Getriebe Nr. 7999  
b) Getriebe Nr. → 8000

Z-Antrieb-Oberteil  
 Stern drive top part  
 Commande partier supérieur  
 Växellada överdel  
 Parte superiore comando ingranaggi

BMW D 150 / D 190 / D 530 / D 636

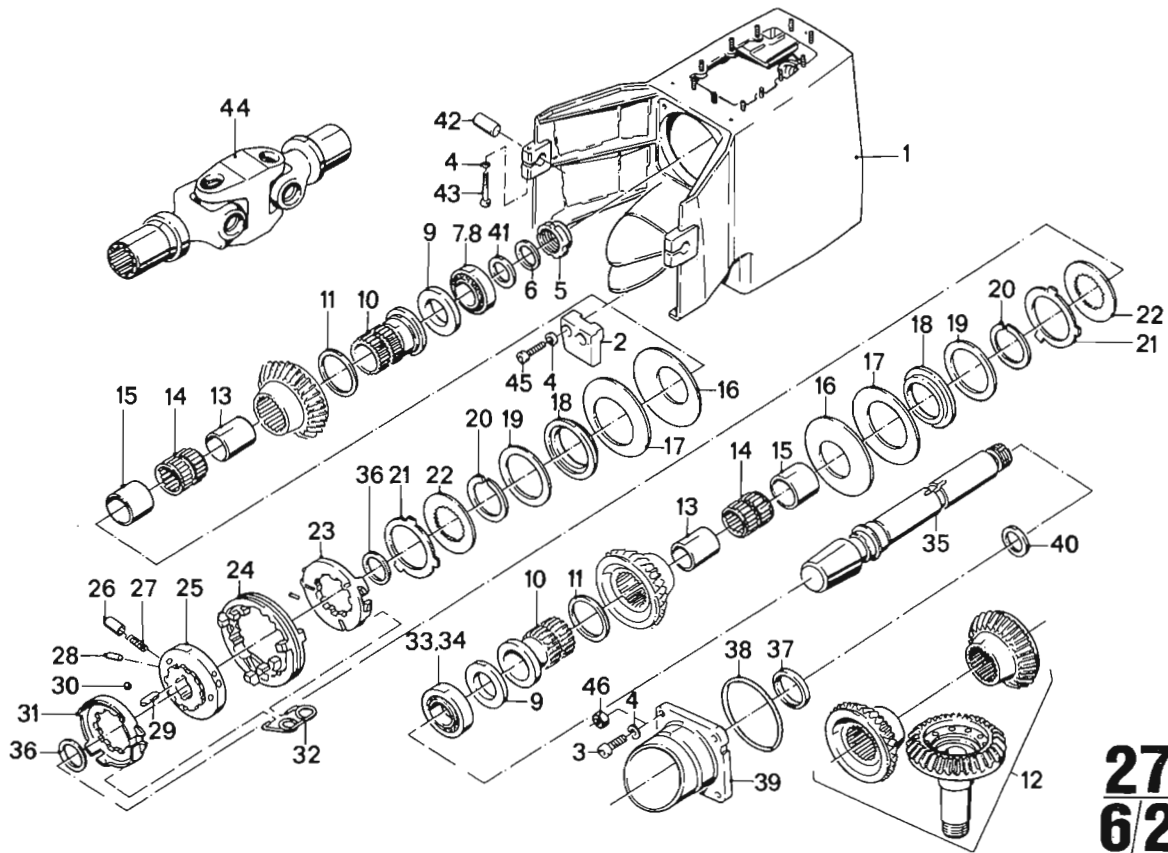

**27**  
**6/2**  
 D 150/190/530/636  
 4/86

27 6/2		4/86										
Nr.	Teile-Nummer	Symbol	Benennung	D 150 Mk I	D 150 Mk II	D 190 Mk II	D 530	D 636	Bemerkung			
14	27 62 1330 602		Nadelkäfig / Needle cage / Cage de palier à aiguilles / Nalbur / Gabbia ad aghi	2	2	2	2	2				
15	27 62 1328 200		Abstandbuchse / Spacer bushing / Douille d'écartement / Avståndsbussning / Nottolino d'arresto	2	2	2	2	2				
16	27 62 1332 072		Tellerfeder / Diaphragm spring / Ressort Belleville / Tallriksfjäder / Molla di disco	2	2	2	2	2				
17	27 62 1332 073		dito	2	2	2	2	2				
18	27 62 1328 182		Druckscheibe / Thrust washer / Ressort belle ville / Tallriskfjäder / Rosetta di pressione	2	2	2	2	2				
19	27 62 1328 992		Scheibe / Washer / Rondelle / Bricka / Rondella	2	2	2		2				
20	27 62 1328 387		Sicherungsring / Snap ring / Circlip / Låsring / Anello di sicurezza	2	2	2	2	2				
21	27 62 1328 179		Außenlamelle / Outer disk / Disque extérieur / Ytterlamell / Lamella esterna	8	8	8	8	8				
22	27 62 1332 418		Innenlamelle / Inner disk / Disque intérieur / Inner lamell / Lamella interna	10	10	10	10	10				
23	27 62 1328 208	R	Lamellenträger / Disk carrier / Support de disque / Lamellhållare / Portalamella	1	1	1						
	27 62 1332 377	R	dito				1	1				
24	27 62 1328 205		Schaltmuffe / Gear shift sleeve / Douille de commande / Kopplingsmuff / Manicotto di comando	1	1	1						
	27 62 1332 378		dito				1	1				
25	27 62 1328 207		Führungsmuffe / Guide sleeve / Douille de guidage / Styrnuff / Manicotto d. guida	1	1	1	1	1				
26	27 62 1328 202		Arretierstift / Retaining pin / Cheville d'arrêt / Låspinne / Bullone d'arresto	3	3	3	3	3				
27	27 62 1328 162		Druckfeder / Compression spring / Ressort de pression / Tryckfjäder / Molla di compressione	3	3	3	3	3				
28	27 62 1328 203		Mitnehmerstift / Driving pin / Broche d'entraînement / Medbringarstift / Perno di trascinamento	3	3	3	3	3				
29	27 62 1328 180		Paßfeder / Feather key / Ressort d'ajustage / Passkil / Chiavetta a molla d'adattam.	2	2	2	2	2				
30	07 11 9986 298		Ø9 Kugel / Ball / Bille / Kula / Sfera	6	6	6	6	6				
31	27 62 1328 206	L	Lamellenträger / Disk carrier / Support de disque / Lamellhållare / Portalamella	1	1	1						
	27 62 1332 376	L	dito				1	1				

a) → Getriebe Nr. 7999  
 b) Getriebe Nr. → 8000

www.bmw-marine.com

V12 Engineering

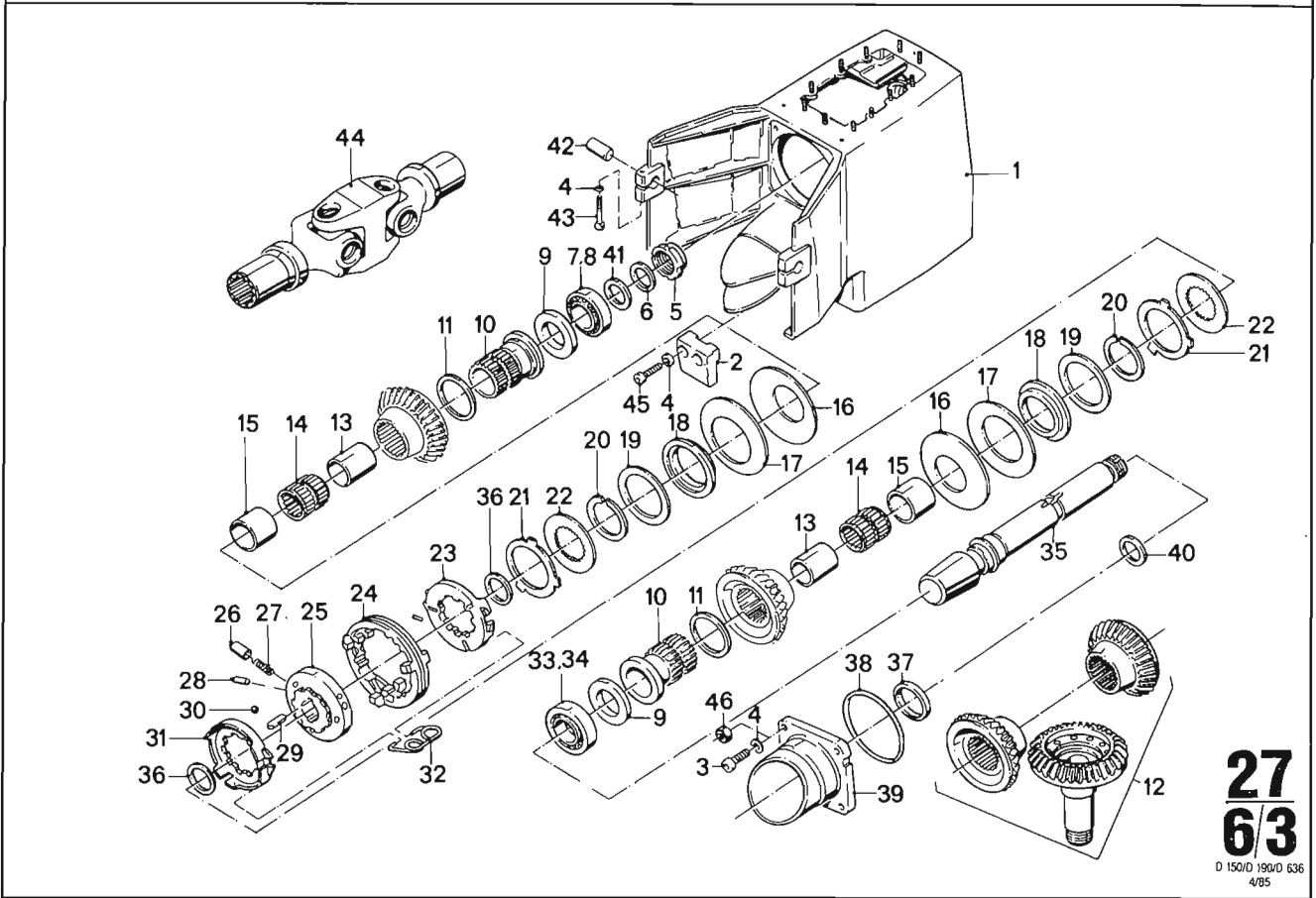

**27**  
**6/3**  
 D 150/D 190/D 530  
 4/85

<b>27</b> <b>6/3</b>		4/86											
Nr.	Teile-Nummer	Symbol	Benennung					D 150 Mk I	D 150 Mk II	D 190 Mk II	D 530	D 636	Bemerkung
32	27 62 1 328 204 27 62 1 332 375		Drehfeder / Torsion spring / Barre de torsion / Dragfjäder / Molla girevole dito					3	3	3			
33	27 62 1 328 391		Innenring / Inner ring / Anneau intérieur / Innerring / Anello interno					1	1	1	1	1	
34	27 62 1 328 392		Außenring / Outer ring / Anneau extérieur / Ytterring / Anello esterno					1	1	1	1	1	
35	a) 27 62 1 330 568		Antriebswelle / Drive shaft / Arbre de commande / Motoraxel / Albero primario					1					
	b) 27 62 1 330 750		dito						1	1	1	1	
36	27 62 1 328 174		0,4 Ausgleichsscheibe / Compensation shim / Disque de compensation / Mellanlägg / Rondella di spessore					X	X	X	X	X	
	27 62 1 328 175		0,5					X	X	X	X	X	
	27 62 1 328 176		0,6					X	X	X	X	X	
	27 62 1 328 177		0,7					X	X	X	X	X	
37	07 119 965 065		Wellendichtring / Shaft seal / Bague d'étanchéité radiale / Tätningring axel / Anello di tenuta					1	1	1	1	1	
38	27 62 1 328 400		O-Ring / O-ring / Joint torique / O-ring / Anello-O					1	1	1	1	1	
39	27 62 1 330 061		Lagerdeckel / Bearing cover / Chapeau de palier / Lagerlock / Coperchio del supporto					1	1	1	1	1	
40	27 62 1 328 152		0,1 Ausgleichsscheibe / Compensation shim / Disque de compensation / Mellanlägg / Rondella di spessore					X	X	X	X	X	
	27 62 1 328 153		0,15					X	X	X	X	X	
	27 62 1 328 154		0,2					X	X	X	X	X	
	27 62 1 328 155		0,5					X	X	X	X	X	
	27 62 1 328 156		1,0					X	X	X	X	X	
41	27 62 1 328 147		0,1 Ausgleichsscheibe / Compensation shim / Disque de compensation / Mellanlägg / Rondella di spessore					X	X	X	X	X	
	27 62 1 328 148		0,15					X	X	X	X	X	
	27 62 1 328 149		0,2					X	X	X	X	X	
	27 62 1 328 151		0,5					X	X	X	X	X	
	27 62 1 328 150		1,0					X	X	X	X	X	
42	27 62 1 328 278		Bolzen / Bolt / Boulon / Bult / Bullone					1	1	1	1	1	
43	07 119 919 746		ZYL SHR M 8 x 40					2	2	2	2	2	

a) → Getriebe Nr. 7999  
 b) Getriebe Nr. → 8000

V12 Engineering  
 www.bmwmarine.com

Z-Antrieb-Oberteil  
 Stern drive top part  
 Commande partier supérieur  
 Växellada överdel  
 Parte superiore comando ingranaggi

BMW D 150 / D 190 / D 530 / D 636

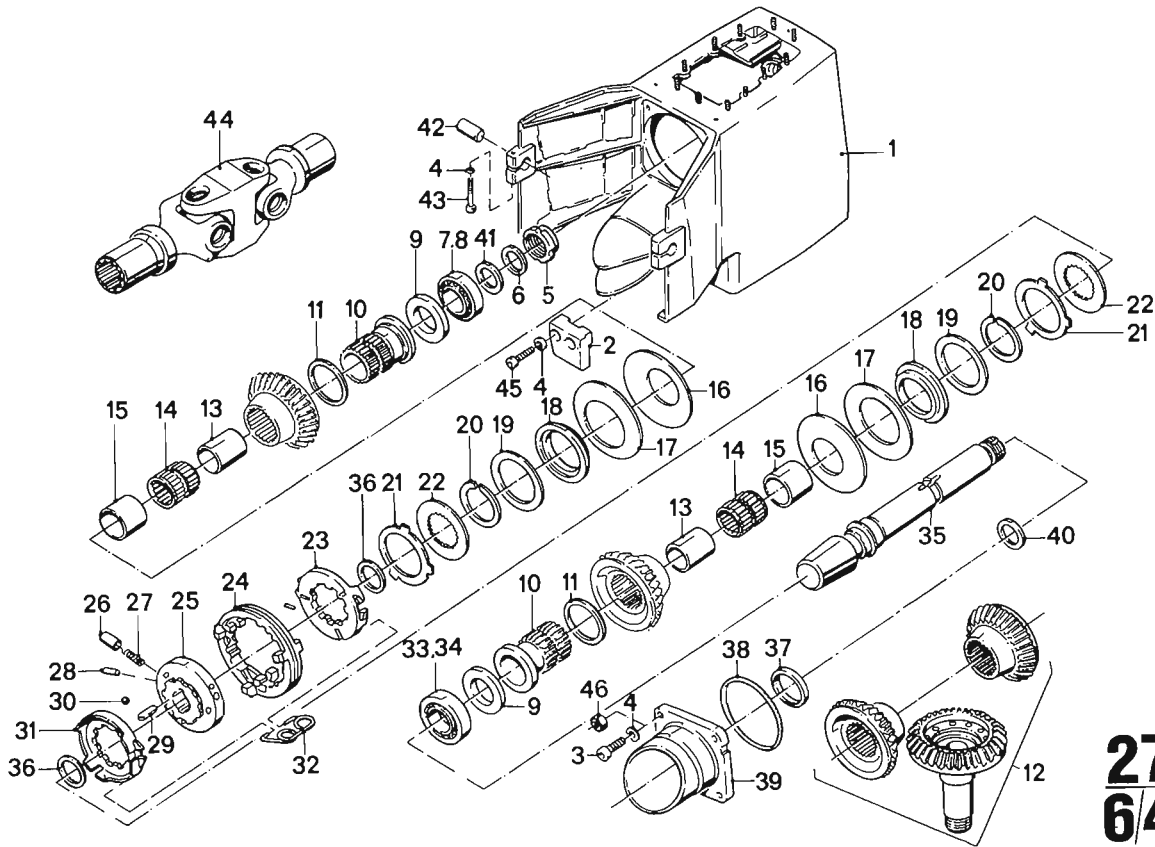

**27**  
**6/4**

D 150/190/530/636  
4/86

<b>27</b> <b>6/4</b>		4/86							
Nr.	Teile-Nummer	Symbol	Benennung	D 150 Mk I	D 150 Mk II	D 190 Mk II	D 530	D 636	Bemerkung
44	a 27 62 1 330 618		1:50 Konus-Doppelgelenk / Conical double joint / Joint conique double / Konisk dubbelled / Doppio giunto cardanico a cono	1					
	b 27 62 1 330 752		1:100 Konus-Doppelgelenk / Conical double joint / Joint conique double / Konisk dubbelled / Doppio giunto cardanico a cono		1	1			
	27 62 1 332 271		dito				1	1	
45	b 07 11 9919 785		ZYL SHR M 8 × 20	2	2	2	4	4	
46	b 07 11 9922 420		6 KT MU M 8		4	4	4	4	

a) → Getriebe Nr. 7999  
 b) Getriebe Nr. → 8000

V12 Engineering

www.bmwmarine.com

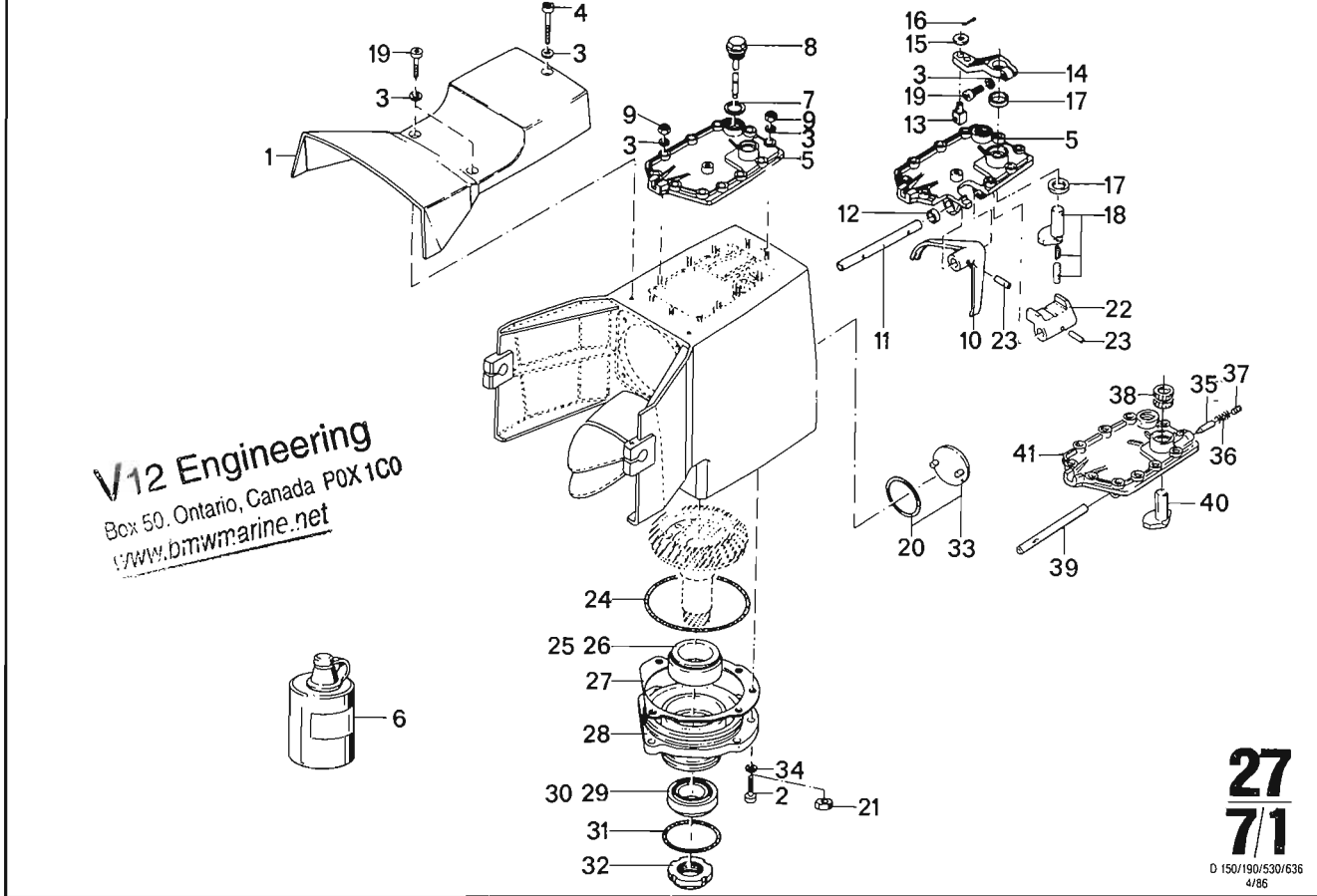

V12 Engineering  
 Box 50, Ontario, Canada POX 100  
 www.bmwmarine.net

27  
 7/1  
 D 150/190/530/636  
 4/86

27 7/1		4/86										
Nr.	Teile-Nummer	Symbol	Benennung	D 150 Mk I	D 150 Mk II	D 190 Mk II	D 530	D 636	Bemerkung			
1	27 62 1 330 059		Deckel / Cover / Couvercle / Lock / Coperchio	1	1	1						
2	a) 07 11 9 919 632		ZYL SHR M 8 x 25	5	5	5		5				
3	07 11 9 932 084		A 8 Federscheibe / Spring washer / Rondelle élastique / Fjäderbricka / Rosetta elastica	20	20	20	12	12				
4	07 11 9 919 747		ZYL SHR M 8 x 55	1	1	1						
5	27 62 1 330 060		Schaltdeckel / Gear shift cover / Couvercle de commande / Växelhusslock / Copricambio	1	1	1						
6	07 58 9 056 979		Dichtmittel / Sealing material / Moyen d'étanchéité / Tätningsmedel / Maateriale sigillante	X	X	X	X	X				
7	07 11 9 963 417		DTRG A 26	1	1	1	1	1				
8	27 62 1 330 452		kpl. Ölmeßstab / Dipstick / Jauge d'huile / Öljemätssticka / Asta controllo livello olio	1	1	1	1	1				
9	07 11 9 921 053		6 KT M U M 8	11	11	11	11	11				
10	27 62 1 328 168		Schaltgabel / Washer / Fourchette de changement de vitesse / Växelförare / Forcella	1	1	1	1	1				
11	27 62 1 328 171		Schaltstange / Shift rod / Arbre de commande des vitesses / Växelföraxel / Asta d. comando	1	1	1						
12	27 62 1 328 163		Lagerbuchse / Bearing bush / Coussinet / Lagerbussning / Boccola di supporto	2	2	2	2	2				
13	27 62 1 328 166		Mitnehmerstift / Driving pin / Broche d'entraînement / Medbringarstift / Perno di trascinamento	1	1	1	1	1				
14	27 62 1 328 169		Schalthebel / Gear shift lever / Levier de commande / Växelspak / Leva di comando	1	1	1	1	1				
15	07 11 9 931 655		8,4 Scheibe / Washer / Rondelle / Bricka / Rondella	1	1	1	1	1				
16	07 11 9 945 098		2 x 12 Splint / Cotter pin / Goupille fendue / Splint / Copiglia	1	1	1	1	1				
17	27 62 1 330 743		DTRG	1	1	1						
	27 62 1 332 374		DTRG				1	1				
18	27 62 1 330 596		Schaltnocke / Shifting cam / Came de commande / Växelkam / Camma di comando	1	1	1						
19	07 11 9 919 775		ZYL SHR M 8 x 25	3	3	3	3	3				
20	27 64 1 328 054		Klebering / Adhesive ring / Anneau adhésif / Klisterring / Anello adesivo	1	1	1	1	1				
21	b) 07 11 9 922 420		6 KT M U M 8	7	7	7	7	7				
22	27 62 1 328 170		Schalteil / Shifting parts / Pièces de commande / Kopplingsdelar / Elemento di innesto	1	1	1						

a) → Getriebe Nr. 7999  
 b) Getriebe Nr. → dito

V12 Engineering  
 www.bmwmarine.com



Schaltdeckel  
Gear shift cover  
Couvercle de commande  
Växelhuslock  
Copricambio

BMW D 150 / D 190 / D 530 / D 636

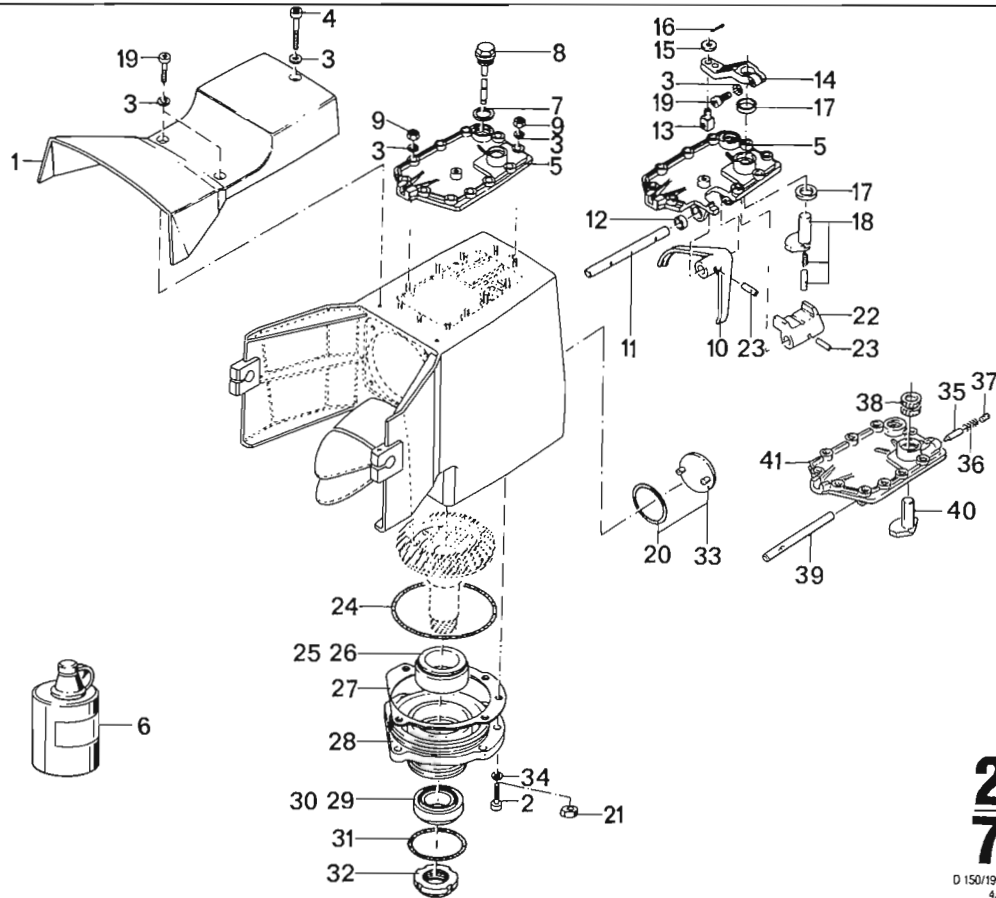

**27**  
**7/2**

D 150/190/530/636  
4/86

27 7/2		4/86										
Nr.	Teile-Nummer	Symbol	Benennung	D 150 Mk I	D 150 Mk II	D 190 Mk II	D 530	D 636	Bemerkung			
23	07 11 9941 389		Spannhülse / Clamping sleeve / Douille de serrage / Spännhylsa / Boccia a tache	2	2	2	2	2				
24	27 62 1 328 400		O-Ring / O-ring / Joint torique / O-ring / Anello-O	1	1	1						
25	27 62 1 328 395		Kegelrollenlager – Innenring / Tapered roller bearing – Inner ring / Roulement à rouleaux – Anneau intérieur / Koniskt rullager – Innerring / Cusc. a rulli conici – Anello interno	1	1	1	1					
26	27 62 1 328 396		dito – Außenring / – Outer ring / – Anneau extérieur / – Yttering / – Anello esterno	1	1	1	1	1				
27	27 62 1 328 209		0,05 Ausgleichsscheibe / Compensation shim / Disque de compensation / Mellanlägg / Rondella di spessore	X	X	X	X	X				
	27 62 1 328 210		0,075	X	X	X	X	X				
	27 62 1 328 211		0,125	X	X	X	X	X				
	27 62 1 328 212		0,25	X	X	X	X	X				
28	27 62 1 330 068		Lagergehäuse / Bearing housing / Carter de roulement / Lagerhus / Carter del cuscinetto	1	1	1	1	1				
29	27 62 1 328 393		Kegelrollenlager – Innenring / Tapered roller bearing – Inner ring / Roulement à rouleaux – Anneau intérieur / Koniskt rullager – Innerring / Cusc. a rulli conici – Anello interno	1	1	1	1	1				
30	27 62 1 328 394		dito – Außenring / – Outer ring / – Anneau extérieur / – Yttering / – Anello esterno	1	1	1		1				
31	27 62 1 328 398		O-Ring / O-ring / Joint torique / O-ring / Anello-O	1	1	1	1	1				
32	27 62 1 328 196		Nutmutter / Grooved nut / Ecrou cannelé / Ringmutter med spår / Ghiera	1	1	1	1	1				
33	27 62 1 330 608		kpl. Plakette / Emblem / Motif / Emblem / Targhetta	1	1	1	1	1				
34	07 11 9931 647		8,4 Scheibe / Washer / Rondelle / Bricka / Rondella	7	7	7	7	7				
35	27 62 1 332 371		Arretierstift / Retaining pin / Cheville d'arrêt / Låspinne / Bullone d'arresto					1				
36	27 62 1 332 372		Druckfeder / Compression spring / Ressort de pression / Tryckfjäder / Molla di compressione					1				
37	07 11 9919 018		VLS SHR					1				
38	27 62 1 332 373		Nadelhülse / Needle sleeve / Douille à aiguilles / Nålhylsa / Bussola ad ago					1				
39	27 62 1 332 370		Schaltwelle / Shift shaft / Arbre de manoeuvre / Kopplingsaxel / Albero d. comando					1				
40	27 62 1 332 361		Schaltnocke / Shifting cam / Came de commande / Växelkam / Camma di comando					1				
41	27 62 1 332 395		Schaltdeckel / Gear shift cover / Couvercle de commande / Växelhuslock / Copricambio					1				

a) → Getriebe Nr. 7999  
b) Getriebe Nr. → 8000

V12 Engineering

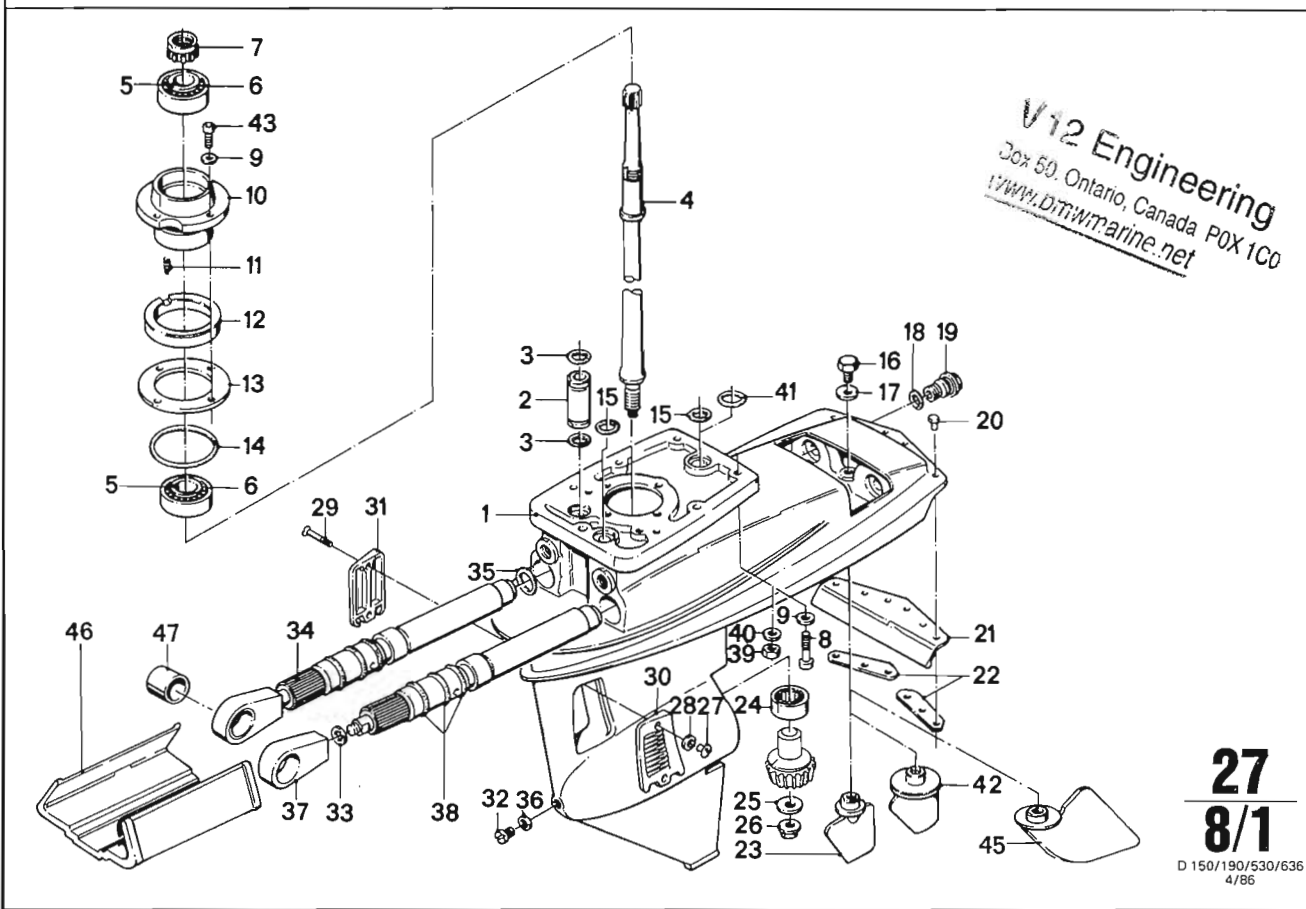

**27**  
**8/1**  
D 150/190/530/636  
4/86

27 8/1		4/86											
Nr.	Teile-Nummer	Symbol	Benennung	D 150 Mk I	D 150 Mk II	D 190 Mk II	D 530	D 636	Bemerkung				
1	a 27 62 1 330 032		Gehäuse-Unterteil / Housing lower part / Carter partie intérieure / Hus underdel / Carter parte inferiore	1									
2	b 27 62 1 330 828 27 62 1 330 067		Ölrücklaufrohr / Oil return pipe / Canalisation de retour / Atergångsledning / Tubo di circolazione olio	1	1	1	1	1					
3	27 62 1 328 414		O-Ring / O-ring / Joint torique / O-ring / Anello-O	2	2	2	2						
4	27 62 1 328 239		Vertikalwelle / Verticalshaft / Arbre vertical / Vertikalaxel / Albero verticale	1	1	1	1						
5	27 62 1 328 409		Kegelrollenlager – Innenring / Tapered roller bearing – Inner ring / Roulement à rouleaux – Anneau intérieur / Koniskt rullager – Innerring / Cusc. a rulli conici – Anello interno	2	2	2	2	2					
6	27 62 1 328 408		dito – Außenring / – Outer ring / – Anneau extérieur / – Yttering / – Anello esterno	2	2	2	2	2					
7	27 62 1 328 173		Nutmutter / Grooved nut / Ecrou cannelé / Ringmutter med spår / Ghiera	1	1	1	1	1					
8	a 07 11 9 91 9 632		ZYL SHR M 8 x 25	7									
9	07 11 9 93 2 084		A 8 Scheibe / Washer / Rondelle / Bricka / Rondella	7	4	4	4	4					
10	27 62 1 330 118		Hackenbüchse / Bearing cover / Chapeau de palier / Lagerlock / Copricuscinetto	1	1	1	1	1					
11	27 62 1 328 238		Druckfeder / Compression spring / Ressort de pression / Tryckfjäder / Molla di compressione	4	4	4	4	4					
12	27 62 1 328 241		Haltering / Holding ring / Anneau de fixation / Låsring / Anello di fissaggio	1	1	1	1	1					
13	27 62 1 328 846		0,05 Einstellscheibe / Flat washer / Rondelle / Bricka / Disco di registrazione	X	X	X	X	X					
	27 62 1 328 845		0,075	X	X	X	X	X					
	27 62 1 328 844		0,125	X	X	X	X	X					
	27 62 1 328 843		0,25	X	X	X	X	X					
14	27 62 1 328 407		O-Ring / O-ring / Joint torique / O-ring / Anello-O	1	1	1	1	1					
15	27 62 1 328 415		dito	2	1	1	1	1					
16	07 11 9 91 3 943		6 KT SHR M 10 x 30	1	1	1	1	1					
17	07 11 9 93 2 117		B 10 Federscheibe / Spring washer / Rondelle élastique / Fjäderbricka / Rosetta elastica	1	1	1	1	1					
18	27 62 1 328 402		O-Ring / O-ring / Joint torique / O-ring / Anello-O	2	2	2	2	2					
19	27 62 1 328 233		SHR	2	2	2	2	2					
20	a 27 62 1 330 282		Niet / Rivet / Rivet / Nietnagel / Rivetto	6									
21	a 27 62 1 328 136		Auspuffklappe / Muffler cut-out / Clapet d'échappement / Avgasklaff / Diaframma nella marmitta	1									

a) → Getriebe Nr. 7999  
b) Getriebe Nr. → 8000

V12 Engineering  
www.bmwmarine.com

Z-Antrieb-Unterteil  
Stern drive lower part  
Commande partie inférieure  
Våxellade underdel  
Parte inferiore comando ingranaggi

BMW D 150 / D 190 / D 530 / D 636

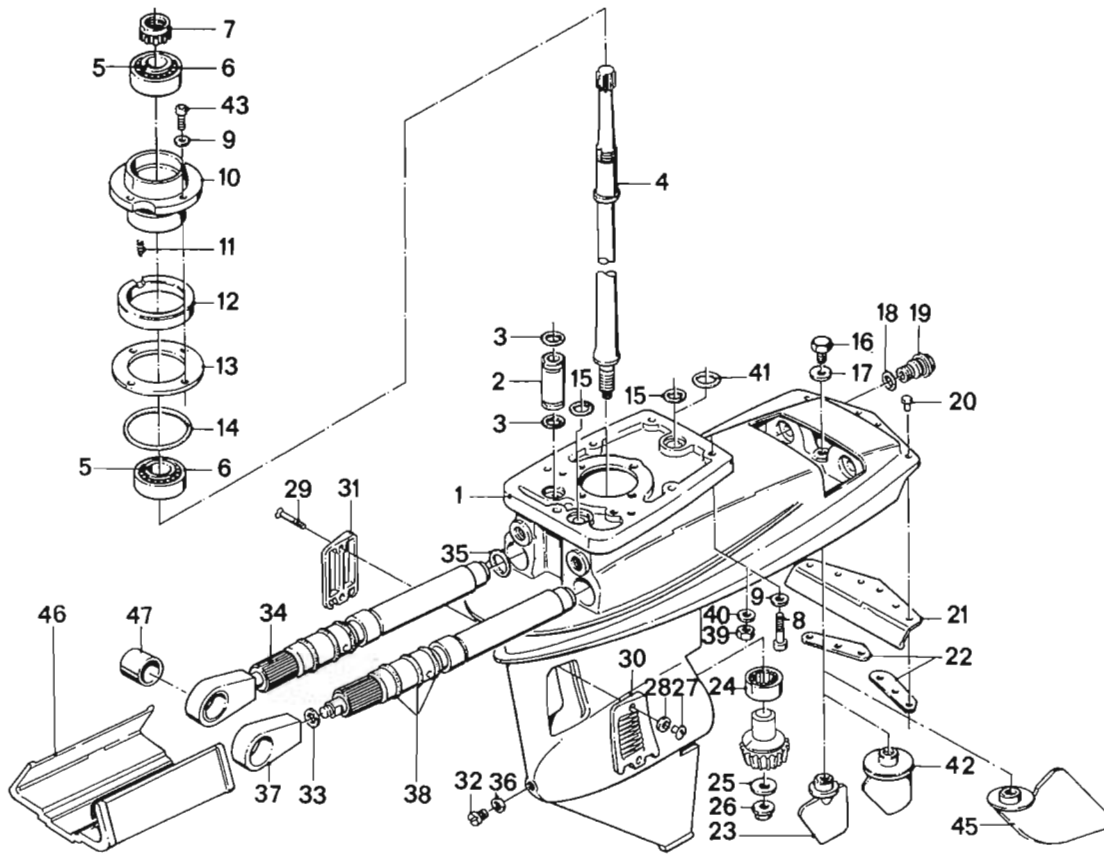

**27**  
**8/2**

D 150/190/530/636  
4/8F

<b>27</b> <b>8/2</b>		4/86										
Nr.	Teile-Nummer	Symbol	Benennung	D 150 Mk I	D 150 Mk II	D 190 Mk II	D 530	D 636	Bemerkung			
22	27 62 1 328 137		Versteifungsblech / Shim / Cale / Underlägg / Rinforzo lamiera	2		2						
23	27 62 1 330 062		Trimmflosse / Trim flap / Plan de trim / Trimroder / Deriva di assetto	1								
24	27 62 1 328 403		Nadellager / Needle bearing / Roulement à aiguilles / Nållager / Cuscinetto a aghi	1	1	1	1	1				
25	27 62 1 328 248		Scheibe / Washer / Rondelle / Bricka / Rondella	1	1	1	1	1				
26	27 62 1 328 413		Mutter / Nut / Moer / Mutter / Dado	1	1	1	1	1				
27	27 62 1 328 138		LIN MU	2		2						
28	a 27 62 1 328 382		Sicherungsring / Snap ring / Circlip / Låsring / Anello di sicurezza	2								
29	a 07 11 9928 796		SK SHR M 6 x 50	2								
30	a 27 62 1 328 132	L	Kieme / Gill / Branchies / Gål / Fiabello	1								
31	a 27 62 1 328 131	R	dito	1								
32	a 07 11 9919 115		VSL SHR M 12 x 1,5	1								
33	27 62 1 328 985		0,1 Ausgleichsscheibe / Compensation shim / Disque de compensation / Mellanlägg / Rondella di spessore	X	X	X	X	X				
	27 62 1 328 986		0,15	X	X	X	X	X				
	27 62 1 328 987		0,2	X	X	X	X	X				
	27 62 1 328 988		0,5	X	X	X	X	X				
	27 62 1 328 989		1,0	X	X	X	X	X				
34	27 62 1 330 598		Hubzylinder / Lift cylinder / Cylindre de élévation / Upplyftaude cylinder / Cilindro di sollevamento	2	2	2	2	2				
35	27 62 1 328 406		O-Ring / O-ring / Joint torique / O-ring / Anello-O	2	2	2	2	2				
36	27 62 1 330 546		DTRG A 12	1	1	1						
37	27 62 1 328 579		Auge / Eye / Oeillet / Oglja / Occhiello	2	2	2	2	2				
38	27 62 1 328 588		O-Ring / O-ring / Joint torique / O-ring / Anello-O	6	6	6	6	6				
39	b 07 11 9922 420		6KT MU M 8	7	7	7	7	7				
40	b 07 11 9931 647		A 8,4 Scheibe / Washer / Rondelle / Bricka / Rondella	7	7	7	7	7				
41	b 27 62 1 330 605		O-Ring / O-ring / Joint torique / O-ring / Anello-O	1	1	1	1	1				
42	b 27 62 1 330 580		Trimmflosse / Trim flap / Plan de trim / Trimroder / Deriva di assetto	1	1							
43	07 11 9919 775		ZYL SHR M 8 x 25	4	4	4	4	4				
44	27 62 1 328 249		Buchse / Bushing / Douille / Bussning / Boccola	2	2	2	2	2				
45	27 62 1 332 365		Trimmflosse / Trim flap / Plan de trim / Trimroder / Deriva di assetto					1	1			
46	27 62 1 330 607		Transportsicherung / Transport insurance / Elément d'arrêt pour transport / Transportsäkring / Dispositivo di sicurezza per trasporto	1	1	1	1	1				
47	27 62 1 328 249		Buchse / Bushing / Douille / Bussning / Boccola	2	2	2	2	2				

a) → Getriebe Nr. 7999  
b) Getriebe Nr. → 8000

Z-Antrieb-Unterteil  
 Stern drive lower part  
 Commande partier inférieure  
 Växellade underdel  
 Parte inferiore comando ingranaggi

BMW D 150 / D 190 / D 530 / D 636

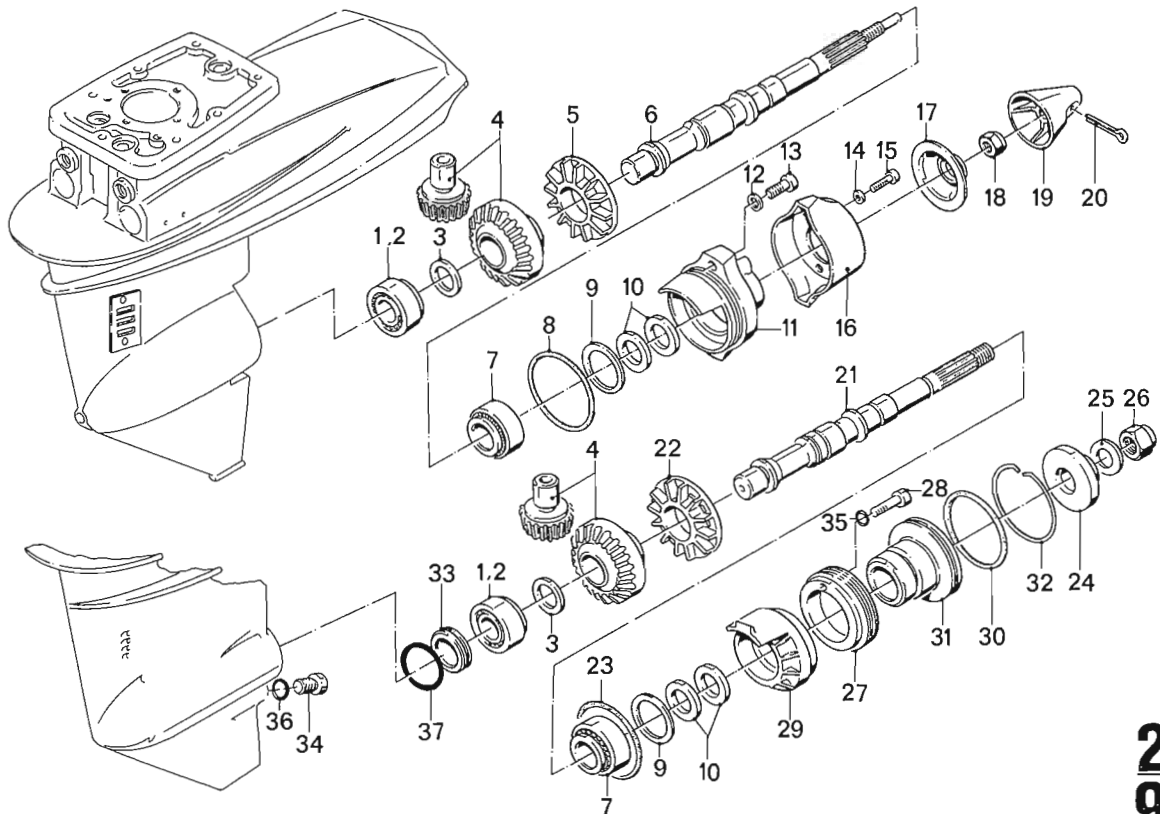

**27**  
**9/1**

D 150/190/530/636  
4/86

<b>27</b> <b>9/1</b>		4/86									
Nr.	Teile-Nummer	Symbol	Benennung	D 150 Mk I	D 150 Mk II	D 190 Mk II	D 530	D 636			Bemerkung
1	27 62 1 328 412		Kegelrollenlager – Innenring / Tapered roller bearing – Inner ring / Roulement à rouleaux – Anneau intérieur / Koniskt rullager – Innerring / Cusc. a rulli conici – Anello interno	1	1	1	1	1			
2	27 62 1 328 404		dito – Außenring / – Outer ring / – Anneau extérieur / – Ytterrings / – Anello esterno	1	1	1	1	1			
3	27 62 1 328 217		0,1 Ausgleichsscheibe / Compensation shim / Disque de compensation / Mellanlägg / Rondella di spessore	X	X	X	X	X			
	27 62 1 328 218		0,15	X	X	X	X	X			
	27 62 1 328 219		0,20	X	X	X	X	X			
	27 62 1 328 220		0,50	X	X	X	X	X			
	27 62 1 328 221		1,00	X	X	X	X	X			
4	27 62 1 328 910		i = 1,61 Tellerradsatz / Wheel set / Train de roues / Hjulsats / Coppia conica	1	1	1					
	27 62 1 332 364		i = 1,61 dito				1	1			
5	a 27 62 1 328 244		Pumpenrad / Impeller / Roue de pompe / Pumphjul / Ruota della pompa	1							
6	a 27 62 1 328 243		Propellerwelle / Cardan shaft / Arbre de commande / Kardanaxel / Albero dell'elica	1							
7	07 11 9985 082		Kegelrollenlager / Tapered roller bearing / Roulement à rouleaux / Koniskt rullager / Cusc. a rulli conici	1	1	1	1	1			
8	a 27 62 1 328 411		O-Ring / O-ring / Joint torique / O-ring / Anello-O	1							
9	27 62 1 328 222		0,1 Ausgleichsscheibe / Compensation shim / Disque de compensation / Mellanlägg / Rondella di spessore	X	X	X	X	X			
	27 62 1 328 223		0,15	X	X	X	X	X			
	27 62 1 328 224		0,20	X	X	X	X	X			
	27 62 1 328 225		0,50	X	X	X	X	X			
	27 62 1 328 226		1,00	X	X	X	X	X			
10	27 62 1 328 234		Radialdichtring / Radial sealing ring / Bague d'étanchéité radiale / Radial packningsring / Guarnizione radiale	2	2	2	2	2			
11	a 27 62 1 330 063		Lagerdeckel / Bearing cover / Capéau de palier / Lagerlock / Coperchio del supporto	1							
12	a 07 11 9931 675		13 Scheibe / Washer / Rondelle / Bricka / Rondella	2							
13	a 07 11 9919 697		ZYL SHR M 12 x 25	2							
14	a 07 11 9932 084		A 8 Federscheibe / Spring washer / Rondelle élastique / Fjäderbricka / Rosetta elastica	2							

a) → Getriebe Nr. 7999  
 b) Getriebe Nr. → 8000

V12 Engineering  
 www.bmwmarine.com

Z-Antrieb-Unterteil  
 Stern drive lower part  
 Commande partie inférieure  
 Växellade underdel  
 Parte inferiore comando ingranaggi

BMW D 150 / D 190 / D 530 / D 636

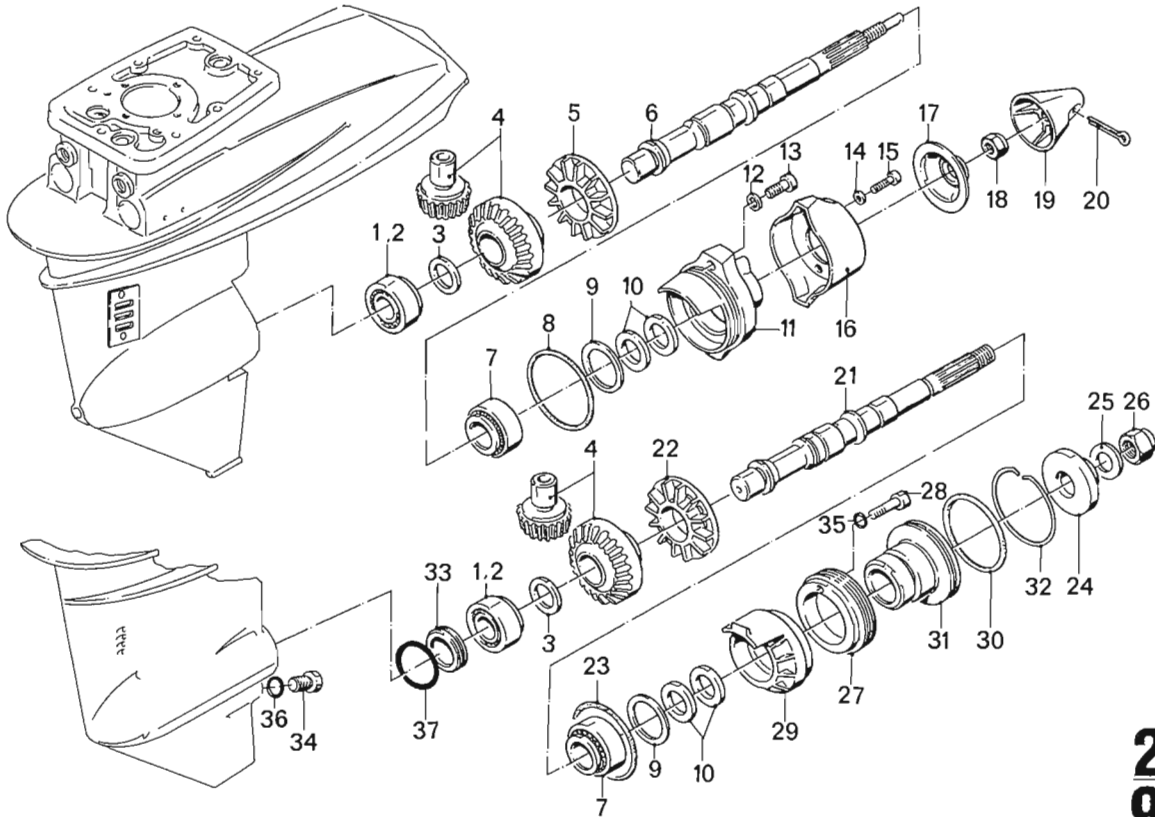

**27**  
**9/2**  
 D 150/190/530/636  
 4/86

<b>27</b> <b>9/2</b>		4/86							
Nr.	Teile-Nummer	Symbol	Benennung	D 150 Mk I	D 150 Mk II	D 190 Mk II	D 530	D 636	Bemerkung
15	a 07 11 9919 632		ZYL SHR M 8 x 25	2					
16	a 27 62 1328 139		Opferanode / Reaktive anode / Anode consommable / Offeranod / Anodo anticorrosione	1					
17	a 27 62 1328 133		Schutzscheibe / Protective disk / Disque protectrice / Skyddsskärm / Disco di protezione	1					
18	a 07 11 9922 493		6 KT SHR / M 20 x 1,5	1					
19	a 27 62 1328 142		Spinner / Spinner / Spinner / Spinner / Spinner	1					
20	a 07 11 9945 255		4 x 45 Splint / Cotter pin / Goupille fendue / Splint / Copiglia	1					
21	b 27 62 1330 604		Propellerwelle / Cardanshaft / Arbre de commande / Kardanaxel / Albero dell'elica		1	1	1	1	
22	b 27 62 1330 582		Pumpenrad / Impeller / Roue de pompe / Pumphjul / Ruota della pompa	1	1	1	1	1	
23	b 27 62 1330 601		O-Ring / O-ring / Joint torique / O-ring / Anello-O	1	1	1	1	1	
24	b 27 62 1330 751		Ring / Ring / Anneau / Ring / Anello	1	1	1	1	1	
25	b 27 62 1330 999		Scheibe / Washer / Rondelle / Bricka / Rondella	1	1	1	1	1	
26	b 07 11 9922 449		6 KT MU M 24 x 1,5	1	1	1	1	1	
27	b 27 62 1330 586		Mutter / Nut / Moer / Mutter / Dado	1	1	1	1	1	
28	b 07 11 9919 775		ZYL SHR M 8 x 25	2	2	2	2	2	
29	b 27 62 1330 584		Lagerdeckel / Bearing cover / Chapeau de palier / Lagerlock / Coperchio del supporto	1	1	1	1	1	
30	b 27 62 1330 599		O-Ring / O-ring / Joint torique / O-ring / Anello-O	1	1	1	1	1	
31	b 27 62 1330 585		Lagerdeckel / Bearing cover / Chapeau de palier / Lagerlock / Coperchio del supporto	1	1	1	1	1	
32	b 27 62 1330 583		Sprengring / Retaining ring / Rondelle Grower / Stopping / Anello elastico	1	1	1	1	1	
33	b 27 62 1330 600		Deckel / Cover / Couvercle / Lock / Coperchio	1	1	1	1	1	
34	b 07 11 9919 119		VSL SHR M 12 x 1,5	1	1	1	1	1	
35	b 07 11 9931 647		8,4 Scheibe / Washer / Rondelle / Bricka / Rondella	2	2	2	2	2	
36	27 62 1330 546		DTRG	1	1	1	1	1	
37	b 27 62 1330 601		O-Ring / O-ring / Joint torique / O-ring / Anello-O	1	1	1	1	1	

a) → Getriebe Nr. 7999  
 b) Getriebe Nr. → 8000

**V12 Engineering**  
 Box 50, Ontario, Canada POX 1C0  
 www.dtmwriar.net

www.v12-engineering.com



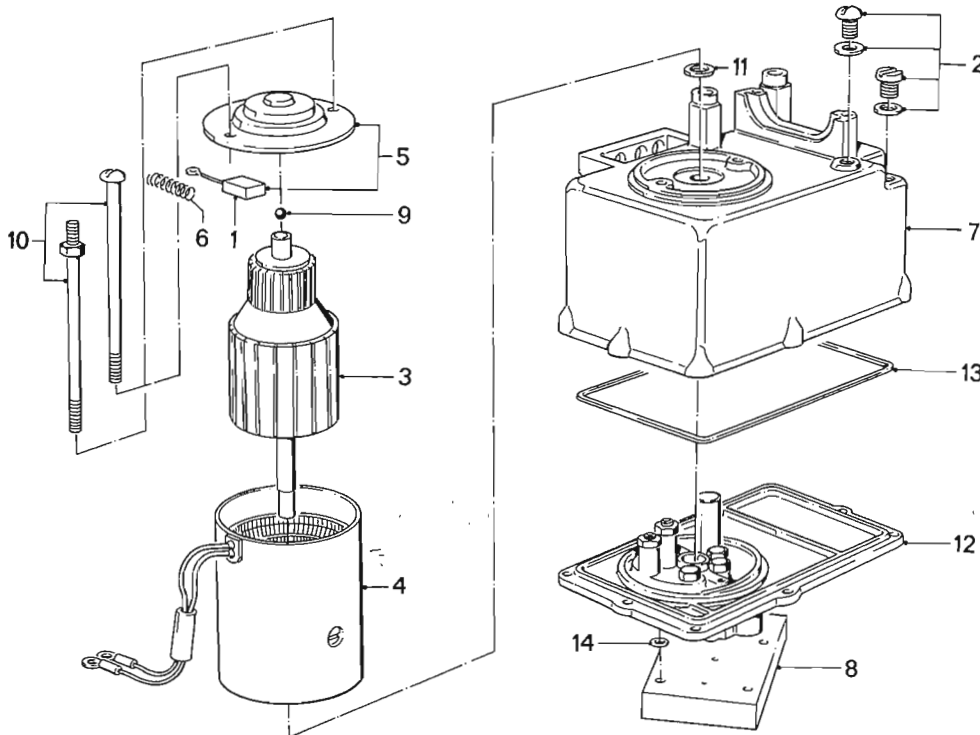

**27**  
**11**

D 150/190/530/636  
4/86

27 11		4/86												
Nr.	Teile-Nummer	Symbol	Benennung					D 150	D 150	D 190	D 530	D 636	Bemerkung	
1	27 64 1 334 178	RS	Kohlebürstensatz / Brush set / Jeu de balais de charbon / Sats kolborstar / Corredo spazz. carbone					1	1	1	1	1		
2	27 64 1 334 177		Schraubensatz / Set of bolts and nuts / Jeu de vis et écroux / Skruvsats / Corredo di viti					1	1	1	1	1		
3	27 64 1 334 426		Anker / Armature / Inducteur / Ankare / Indotto					1	1	1	1	1		
4	27 64 1 334 427		Erregerwicklung / Field coil / Bobinage d'excitation / Lidning / Avvolgimento eccitat.					1	1	1	1	1		
5	27 64 1 334 428		Kommutatorlager / Collector bearing / Palier de collecteur / Kommutatorlager / Supporto del collettore					1	1	1	1	1		
6	27 64 1 334 429		Bürstenfedersatz / Brush spring set / Jeu ressorts à broches / Borstfjädersats / Corredo molle di ritegno della spazzola					1	1	1	1	1		
7	27 64 1 334 430		Pumpengehäuse / Pumpe housing / Boîtier de la pompe / Pumphus / Carter della pompa					1	1	1	1	1		
8	27 64 1 330 482		Steuerplatte / Control plate / Plaque de commande / Manöverplatte / Piastra di comando					1	1	1	1	1		
9	27 64 1 334 431		Stahlkugel / Steel ball / Bille en acier / Stålkula / Sfera d'acciaio					1	1	1	1	1		
10	27 64 1 334 432		Bolzenschraubensatz / Bolt screw set / Jeu boulons / Sats bultskruvar / Corredi viti per bulloni					1	1	1	1	1		
11	27 64 1 334 433		Druckscheibe / Thrust washer / Ressort belle ville / Tallriskfjäder / Rosetta di pressione					1	1	1	1	1		
12	27 64 1 334 434		Getriebegehäuse / Gearbox-Housing / Boîte à vitesse-Boite / Växel-Hus / Gruppo propulsiore-Scatola					1	1	1	1	1		
13	27 64 1 334 435		DTRG					1	1	1	1	1		
14	a 27 64 1 334 436	RS	O-Ring-Satz / O-ring set / Jeu de joint torique / Sats O-ring / Corredo anello-O					1	1	1	1	1		

a) 4 Stück / 4 Piece / 4 Elément / 4 Stycke / 4 Pezzo

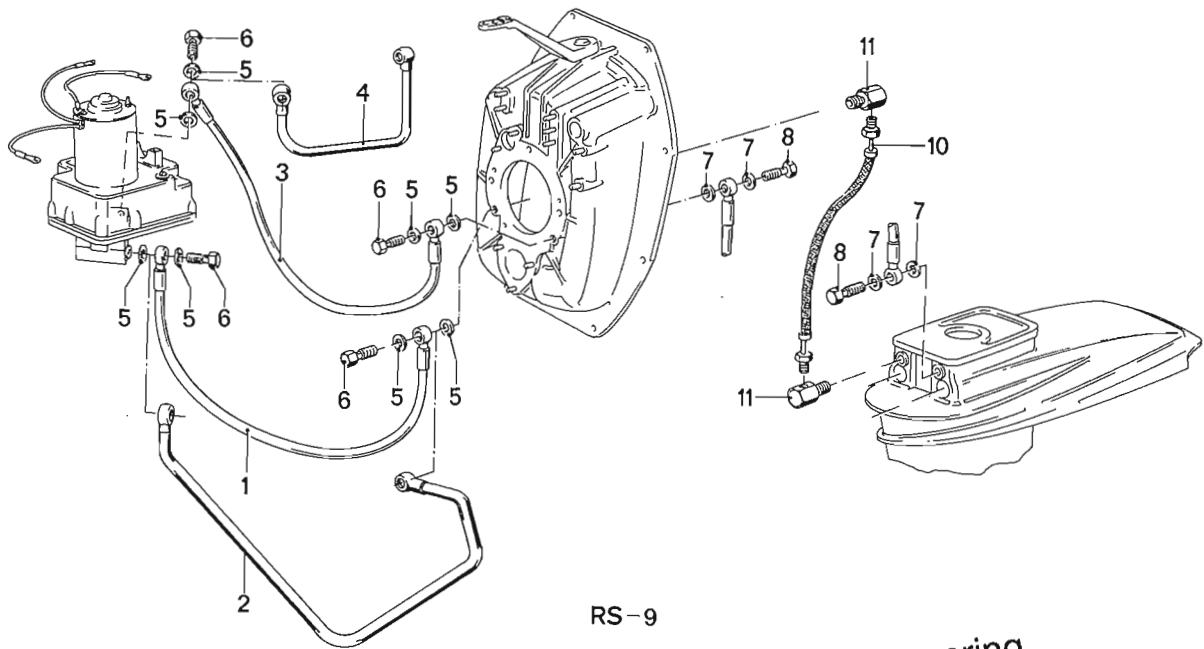

RS-9

V12 Engineering  
Box 50, Ontario, Canada POX 1C0  
www.bmwmarine.net

27  
12

D 150/190/530/636  
4/86

Nr.	Teile-Nummer	Symbol	Benennung	D 150 Mk I	D 150 Mk II	D 190 Mk II	D 530	D 636	Bemerkung
1	27 62 1 326 897	WW	Hydraulikschlauch / Hydraulic hose / Flexible hydraulique / Hydraulisk slang / Tubo flessibile idraulico	1	1	1	1	1	
2	27 62 1 328 332	WW	Hydraulikleitung / Hydraulic line / Tuyauterie hydraulique / Hydraulisk ledning / Conduttura idraulica	1	1	1	1	1	
3	27 62 1 326 896	WW	Hydraulikschlauch / Hydraulic hose / Flexible hydraulique / Hydraulisk slang / Tubo flessibile idraulico	1	1	1	1	1	
4	27 62 1 328 330	WW	Hydraulikleitung / Hydraulic line / Tuyauterie hydraulique / Hydraulisk ledning / Conduttura idraulica	1	1	1	1	1	
5	07 11 9 963 150		DTRG A 12 x 17	8	8	8	8	8	
6	07 11 9 917 409		Hohlschraube / Banjo bolt / Vis creuse / Banjobult / Vite cava	4	4	4	4	4	
7	27 62 1 330 546		DTRG A 12 x 17	8	8	8	8	8	
8	27 62 1 328 832		Hohlschraube / Banjo bolt / Vis creuse / Banjobult / Vite cava	4	4	4	4	4	
9	a 27 62 1 332 679	RS	kpl. Nachrüstkit / Supplement kit / Jeu de rattrapage / Modifikationskit / Corredo di modifica	1	1	1	1	1	
10	27 62 1 330 981		dito	2	2	2	2	2	
11	27 62 1 332 678		Winkelstück / Angle plate / Pièce coudée / Vinkelstycke / Pezzo angolare	4	4	4	4	4	

a) beinhaltet Pos. 11 + Loctite und Aktivator / contains Items 11 + Loctite and activator /  
Comporte pos. 11 + Loctite et activateur / omfatter pos. 11 + Loctite och aktivator / Comprende posizione 11 + Loctite ed attivatore



Getriebeölkühlung  
 Gear oil radiator  
 Radiateur d'huile de boîte de vitesses  
 Kylare för växellådsolja  
 Radiatore dell'olio per gruppo propulsore

BMW D 150 / D 190 / D 530 / D 636

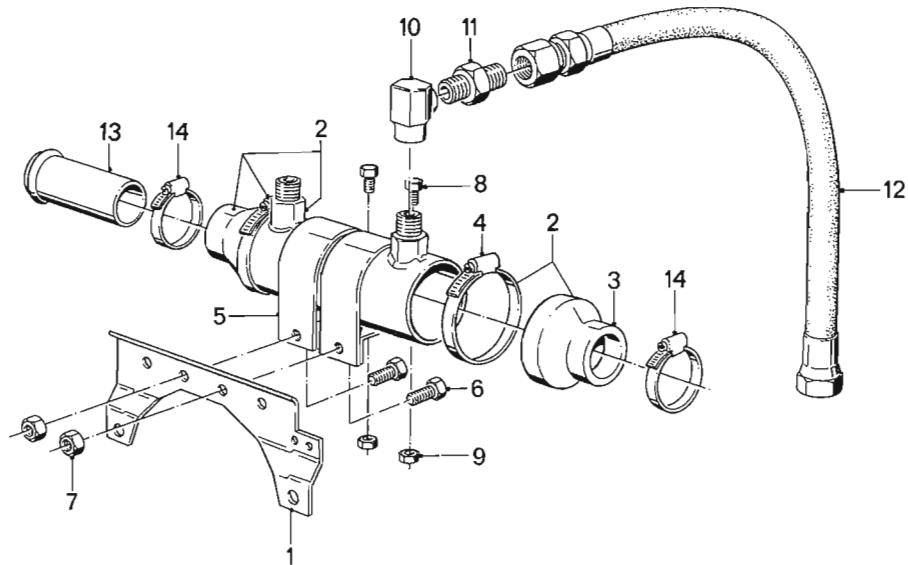

**27**  
**13**

D 150/190/530/636  
4/86

<b>27</b> <b>13</b>		4/86								
Nr.	Teile-Nummer	Symbol	Benennung	D 150	D 150	D 190	D 530	D 636	Bemerkung	
1	27 63 1 326 972		Halteblech / Retaining plate / Tôle de retenue / Fästplat / Lamiera di sostegno	1		1	1	1		
2	17 21 1 761 376		kpl. Ölkühler / Oil cooler / Réfrigérant d'huile / Oljekylare / Radiatore dell'olio	1		1	1	1		
3	17 12 1 761 375		Endkappe / Cover cap / Capuchon final / Slutstycke / Calotta terminale	2		2	2	2		
4	11 53 1 328 048		40-60 Schelle / Clamp / Collier / Klämna / Fascetta	2		2	2	2		
5	27 63 1 763 507		Befestigungsschelle / Attaching clamp / Collier de fixation / Fästklammer / Collare de fissaggio	2		2	2	2		
6	07 11 9 913 624		6 KT SHR M 8 x 16	2		2	2	2		
7	07 11 9 922 087		6 KT MU M 8	2		2	2	2		
8	07 11 9 913 442		6 KT SHR M 6 x 12	2		2	2	2		
9	07 11 9 922 058		6 KT MU M 6	2		2	2	2		
10	27 63 1 761 919		Winkelschraubstutzen / Angular screw socket / Manchon fileté angulaire / Vinkelskrurvuff / Bocchettone filettato ad angolo	2		2	2	2		
11	27 63 1 330 753		Verbindungsstutzen / Connection piece / Manchon de raccord / Förbindningsmuff / Bocchettone di raccordo	2		2	2	2		
12	27 63 1 330 744		Ölleitung / Oil pipe / Conduite d'huile / Oljeledning / Tubatura olio	2		2	2	2		
13	17 12 1 761 587		Seewasserrohr / Sea water pipe / Tube à eau de mer / Havsvattenrör / Tubo acqua di mare	1		1	1	1		
14	11 53 1 326 639		32-50 Schelle / Clamp / Collier / Klämna / Fascetta	2		2	2	2		

V12 Engineering

www.bmwmarine.com

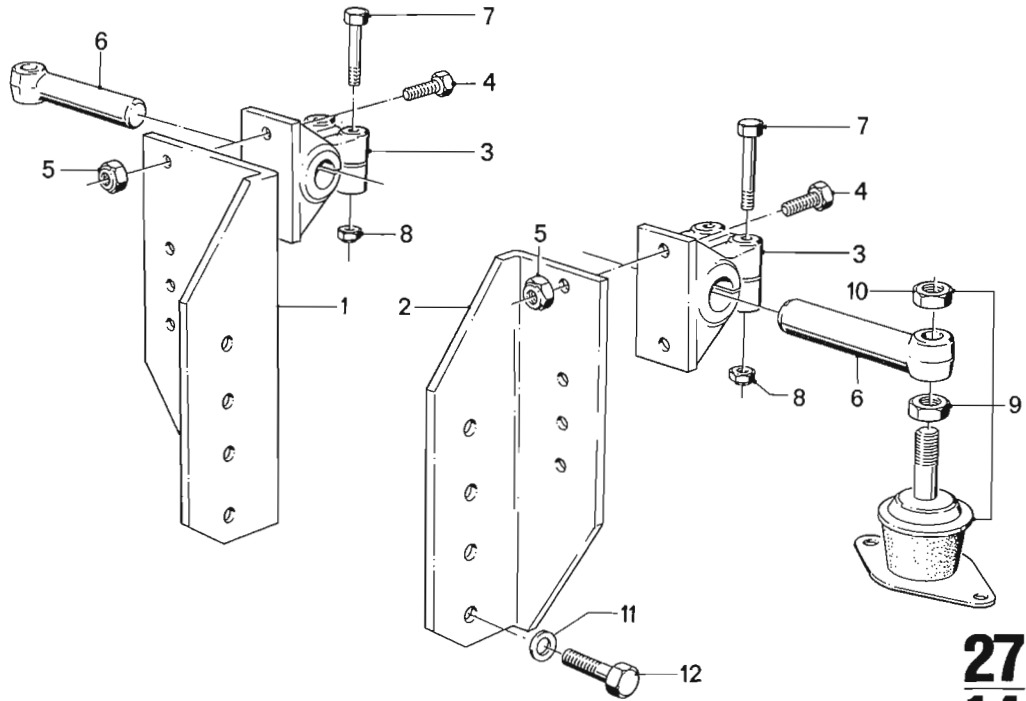

**27**  
**14**  
D 150/D 190/D 530  
4/86

27/14		4/86							
Nr.	Teile-Nummer	Symbol	Benennung	D 150	D 190	D 530	D 636	Bemerkung	
1	a 2371 1761 388	L	Haltewinkel / Support angle / Corniere d'appui / Vinkelstöd / Squadra di sostegno	1	1	1			
	b 2371 1761 621	L	dito	1	1	1			
2	a 2371 1761 386	R	Haltewinkel / Support angle / Corniere d'appui / Vinkelstöd / Squadra di sostegno	1	1	1			
	b 2371 1761 620	R	dito	1	1	1			
3	2371 1761 389		Spannpratze / Tightening claw / Griffe de serrage / Spänngaffel / Griffa di serraggio	2	2	2			
4	07 11 9913 837		6KT SHR M 10 x 30	4	4	4			
5	07 12 9922 430		6KT MU M 10	4	4	4			
6	1181 1763 304		Lagerbolzen / Fitting bolt / Boulon de palier / Lagerbolt / Perno d'articolazione	2	2	2			
7	07 11 9912 524		6KT SHR M 8 x 55	4	4	4			
8	07 12 9922 426		6KT MU M 8	4	4	4			
9	1181 1761 146		kpl. Konuslager / Tapered bearing / Palier conique / Koniskt lager / Cuscinetto a rulli conici	2	2	2			HS 75
10	07 11 9922 176		6KT MU M 16 x 1,5	4	4	4			
11	a 07 11 9931 084	WW	13 Scheibe / Washer / Rondelle / Bricka / Rondella	4	4	4			
	b 07 11 9931 332	WW	10,5 dito	4	4	4			
12	a 07 11 9913 889	WW	6KT SHR M 12 x 35	4	4	4			
	b 07 11 9913 917	WW	6KT SHR M 10 x 35	4	4	4			

a) Nur für HBW 360 / For HBW 360 only / Uniquement pour HBW 360 / Bara för HBW 360 / Solo per HBW 360  
 b) Nur für HBW 450 / For HBW 450 only / Uniquement pour HBW 450 / Bara för HBW 450 / Solo per HBW 450

Getriebeaufhängung  
 Gearbox suspension  
 Suspension de commande  
 Växelupphängning  
 Sospensione del gruppo propulsore

BMW D 150 / D 190 / D 530 / D 636

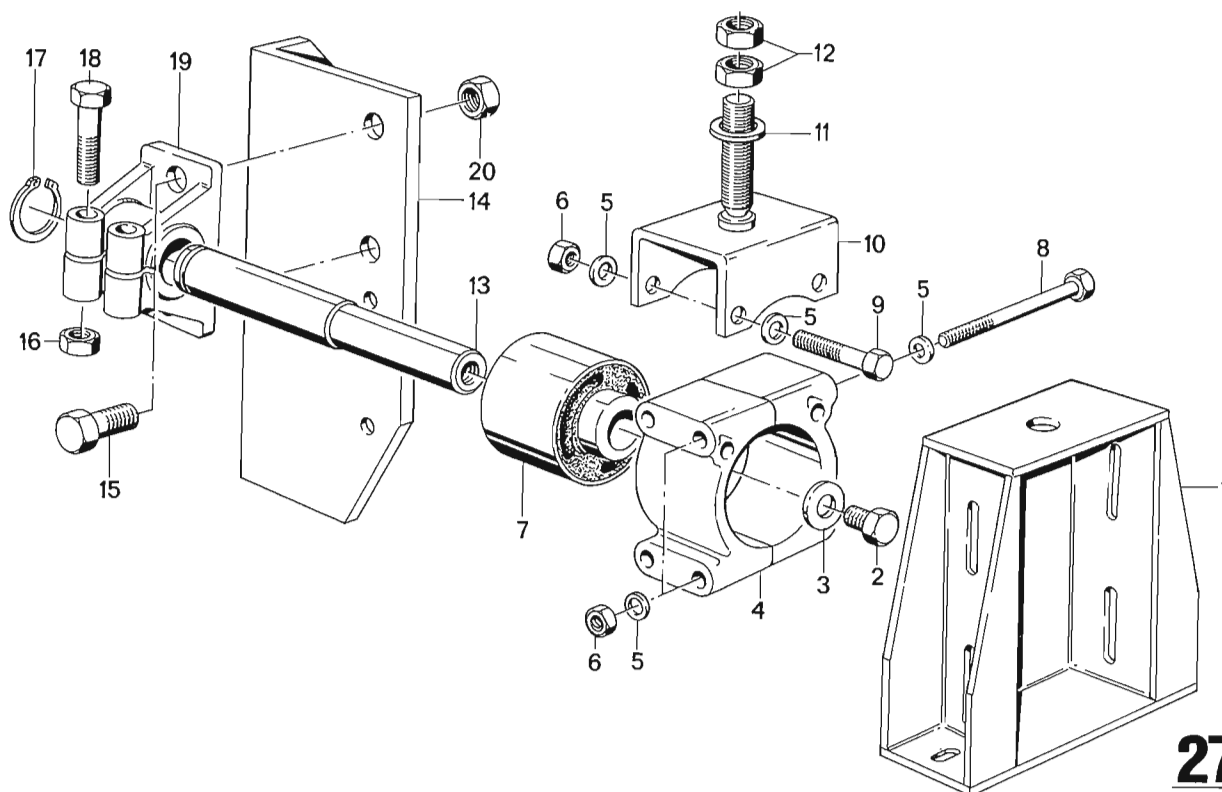

**27**  
**15**  
D 530  
4/86

27 15		4/86							
Nr.	Teile-Nummer	Symbol	Benennung	D 150	D 190	D 530	D 636	Bemerkung	
1	2371 1763869		Lagerbock / Bearing bracket / Palier / Lagerbock / Cavalletto d. supporto			2			
2	07 119913807		6 KT SHR M 10 x 12			2			
3	07 119936436		10,5 Scheibe / Washer / Rondelle / Bricka / Rondella			2			
4	2371 1763870		Gehäuse / Housing / Carter / Hus / Scatola			2			
5	07 119931067		A 8,4 Scheibe / Washer / Rondelle / Bricka / Rondella			8			
6	07 119922808		6 KT MU M 8			4			
7	2371 1763874		Buchsenlager / Bush bearing / Palier de douille / Hylslager / Supporto boccola			2		HS 55	
8	07 119912578		6 KT SHR M 8 x 110			4			
9	07 119912553		6 KT SHR M 8 x 75			4			
10	2371 1763877		U-Teil / U-piece / Pièce en U / U-stycke / Pezzo U			2			
11	07 119931094		A 17 Scheibe / Washer / Rondelle / Bricka / Rondella			2			
12	07 119921102		6 KT MU			4			
13	2371 1763909		Lagerbolzen / Fitting bolt / Boulon de palier / Lagerbult / Perno d'articolazione			2			
14	a 2371 1763889	L	Haltewinkel / Support angle / Corniere d'appui / Winkelstöd Squadra di sostegno			1			
	a 2371 1763890	R	dito			1			
15	07 119913837		6 KT SHR M 10 x 30			4			
16	07 119922426		6 KT MU			4			
17	07 119934175		Sicherungsring / Snap ring / Circlip / Låsring / Anello de sicurezza			2			
18	07 119912524		6 KT SHR M 8 x 55			4			
19	2371 1333897		Spannpratze / Tightening claw / Griffes de serrage / Spänngaffel / Griffa di serraggio			2			

a) Nur für HBW 360-360A / For HBW 360-360A only / Uniquement pour HBW 360-360A / Bara för HBW 360-360A / Solo per HBW 360-360A

Wendegetriebe – Hurth HBW 360 / 360 A / 450  
 Reversing transmission – Hurth HBW 360 / 360 A / 450  
 Réducteur-inverseur – Hurth HBW 360 / 360 A / 450  
 Backväxel – Hurth HBW 360 / 360 A / 450  
 Cambio ad inversione di marcia – Hurth HBW 360 / 360 A / 450

BMW D 150 / D 190 / D 530 / D 636

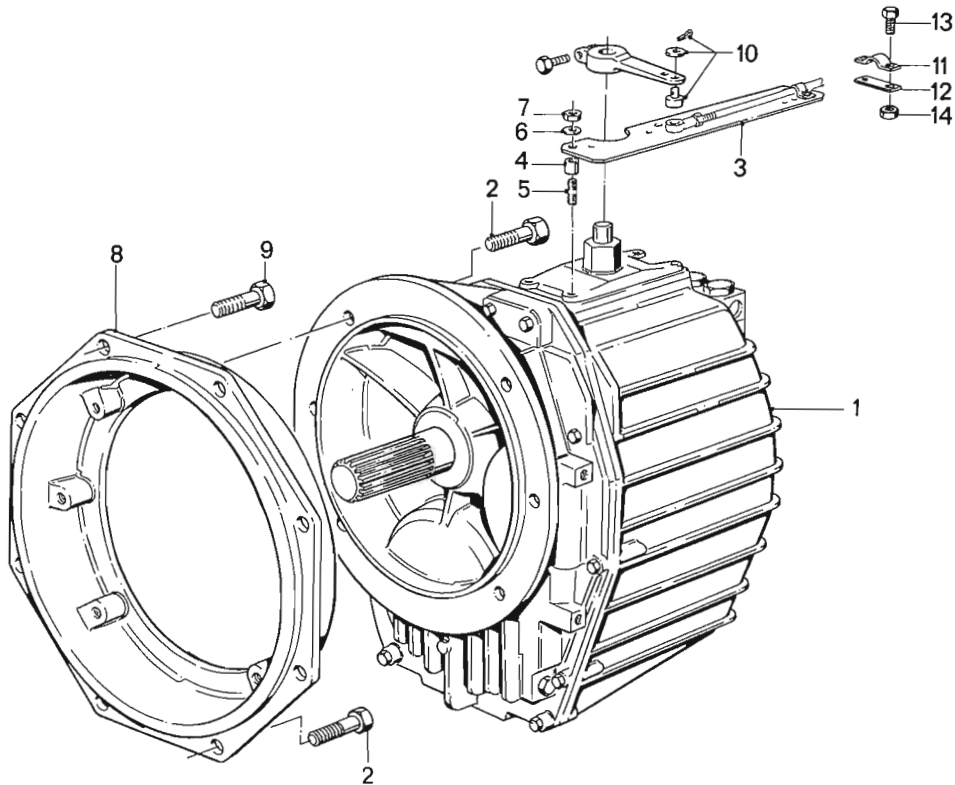

**27**  
**16**

D 150/190/530/636  
4/86

27 16		4/86									Bemerkung
Nr.	Teile-Nummer	Symbol	Benennung	D 150	D 190	D 530	D 636				
1	27 63 1763 547		HBW 360 Wendegetriebe / Reversing transmission / Réducteur-inverseur / Backväxel / Cambio ad inversione di marcia	1	1	1	1				
	27 63 1763 548		1,5:1	1	1	1	1				
	27 63 1763 549		2,0:1	1	1	1	1				
	27 63 1763 554		HBW 360 A Wendegetriebe / Reversing transmission / Réducteur-inverseur / Backväxel / Cambio ad inversione di marcia	1	1	1	1				
	27 63 1763 555		1,5:1	1	1	1	1				
	27 63 1763 556		2,0:1	1	1	1	1				
	27 63 1761 776		HBW 450 Wendegetriebe / Reversing transmission / Réducteur-inverseur / Backväxel / Cambio ad inversione di marcia	1	1	1	1				
	27 63 1761 777		1,5:1	1	1	1	1				
	27 63 1761 778		2,0:1	1	1	1	1				
2	07 11 9913 837		6 KT SHR M 10 x 30	12	12	12	12				
3	27 63 1333 793		Halteblech / Retaining plate / Tôle de retenue / Fästplåt / Lamiera di sostegno	1	1	1	1				
4	27 63 1761 106		Distanzbuchse / Spacer socket / Douille d'écartement / Distanshylsa / Boccia distanziatore	2	2						
5	07 11 9909 079		STI SHR M 8 x 35	2	2	2	2				
6	07 11 9931 067		A 8,4 Scheibe / Washer / Rondelle / Bricka / Rondella	2	2	2	2				
7	07 12 9922 426		6 KT MU M 8	2	2	2	2				
8	27 63 1761 688		Zwischenflansch / Intermediate flange / Bride intermédiaire / Mellanfläns / Flangia intermedia	1	1	1	1				
9	07 11 9913 807		6 KT SHR M 10 x 12	1	1	1	1				
10	1321 1328 524		Schaltteile / Shifting parts / Pièces de commande / Kopplingsdelar / Elemento di innesto	1	1						
11	1321 1326 574		Klemmbügel / Clamp strap / Etrier de serrage / Klämbügel / Staffa di serraggio	1	1	1	1				
12	1321 1331 346		Unterlage / Spacer / Joint / Underlägg / Piastrina	1	1	1	1				
13	07 11 9913 251		6 KT SHR M 5 x 20	2	2	2	2				
14	07 12 9922 410		6 KT MU M 5	2	2	2	2				

V12 Engineering  
www.bmwmarine.com

Hurth HBW 360 / 360 A / 450  
 Hurth HBW 360 / 360 A / 450  
 Hurth HBW 360 / 360 A / 450  
 Hurth HBW 360 / 360 A / 450  
 Hurth HBW 360 / 360 A / 450

BMW D 150 / D 190 / D 530 / D 636

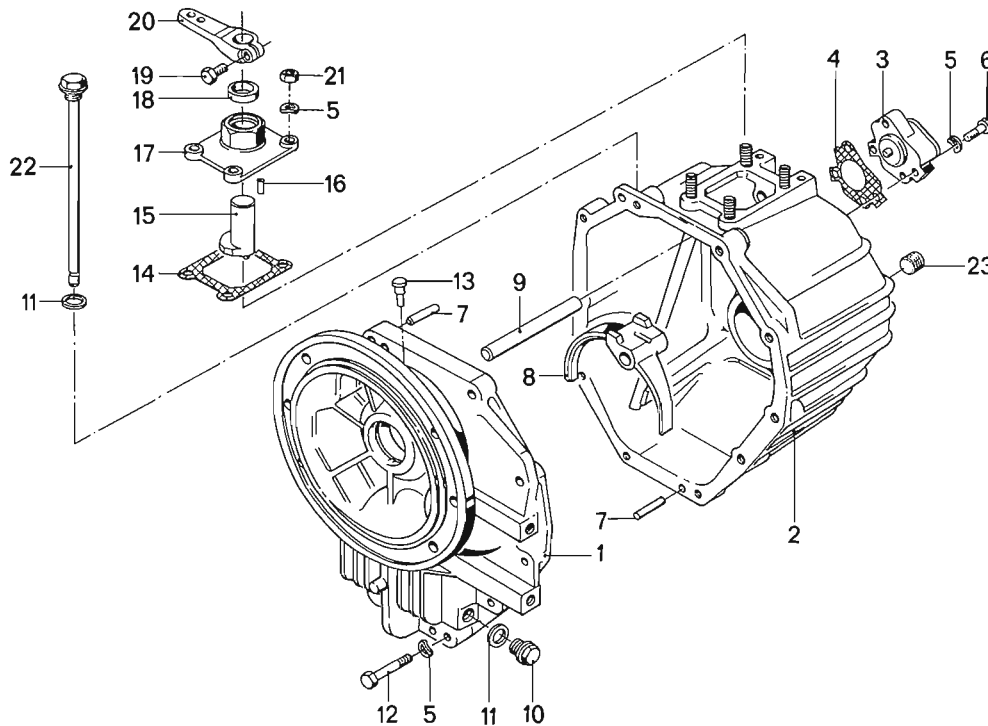

**27**  
**17/1**

D 150/190/530/636  
4/86

27 17/1		4/86									
Nr.	Teile-Nummer	Symbol	Benennung	D 150	D 190	D 530	D 636	Bemerkung			
1	a 27 63 1761 933		Gehäusedeckel / Housing cover / Couvercle de carter / Huskåpa / Coperchio del carter	1	1	1	1				
	b 27 63 1761 997		dito	1	1	1	1				
	c 27 63 1761 065		dito	1	1	1	1				
2	a 27 63 1761 934		Gehäuse / Housing / Carter / Hus / Scatola	1	1	1	1				
	b 27 63 1761 998		dito	1	1	1	1				
	c 27 63 1761 066		dito	1	1	1	1				
3	27 63 1761 935		kpl. Ölpumpe / Oil pump / Pompe à huile / Oljepump / Pompa olio	1	1	1	1				
4	27 63 1761 938		Dichtung / Seal / Garniture / Packning / Guarnizione	1	1	1	1				
5	07 11 993 2095		B 8 Federscheibe / Spring washer / Rondelle élastique / Fjäderbricka / Rosetta elastica	6	6	6	6				
6	07 11 991 9643		ZYL SHR M 8 x 30	2	2	2	2				
7	a c 27 63 1761 993		ZYL ST1	1	1	1	1				
	b 27 63 1763 085		dito	1	1	1	1				
8	27 63 1761 952		kpl. Schaltgabel / Shift fork / Fourchette de changement de vitesse / Växelförare / Forcella	1	1	1	1				
9	27 63 1761 489		Schaltstange / Shift rod / Arbre de commande des vitesses / Växelföraraxel / Asta d. comando	1	1	1	1				
10	27 63 1331 262		VSL SHR	1	1	1	1				
11	07 11 996 3252		DT RG	2	2	2	2				
12	07 11 991 3676		6 KT SHR M 8 x 35	16	16	16	16				
13	27 63 1761 990		Entlüftungsventil / Bleed valve / Soupape de purge / Luftningsventil / Valvola spargo aria	1	1	1	1				
14	27 63 1331 271		Dichtung / Seal / Garniture / Packning / Guarnizione	1	1	1	1				
15	27 63 1761 986		kpl. Schaltnocke / Shifting cam / Came de commande / Växelkam / Camma di comando	1	1	1	1				
16	07 11 994 1385		4 x 12 Spannstift / Spring dowel sleeve / Goupille de serrage / Spannstift / Perno tenditore di fissaggio	1	1	1	1				
17	27 63 1331 265		Schaltdeckel / Gear shift cover / Couvercle de commande / Växelhuslock / Copricambio	1	1	1	1				
18	27 63 1331 270		DTRG	1	1	1	1				

a) Nur für HBW 360 / For HBW 360 only / Uniquement pour HBW 360 / Bara för HBW 360 / Solo per HBW 360  
 b) Nur für HBW 360 A / For HBW 360 A only / Uniquement pour HBW 360 A / Bara för HBW 360 A / Solo per HBW 360 A  
 c) Nur für HBW 450 / For HBW 405 only / Uniquement pour HBW 405 / Bara för HBW 450 / Solo per HBW 450

www.bmw-engineering.com

Hurth HBW 360 / 360 A / 450  
 Hurth HBW 360 / 360 A / 450  
 Hurth HBW 360 / 360 A / 450  
 Hurth HBW 360 / 360 A / 450  
 Hurth HBW 360 / 360 A / 450

BMW D 150 / D 190 / D 530 / D 636

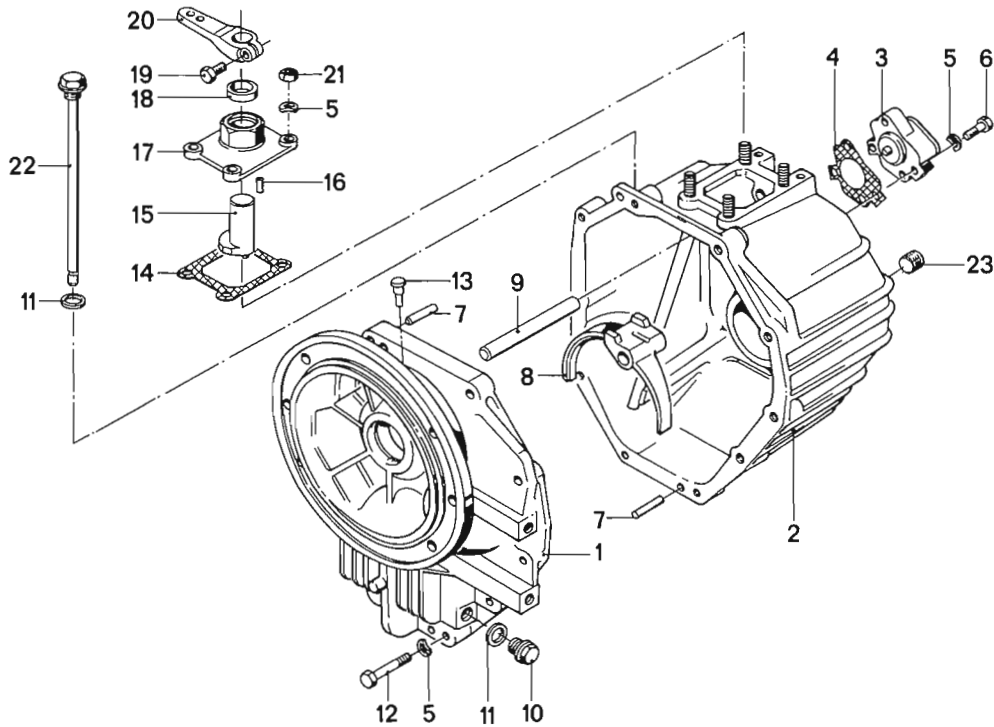

**27**  
**17/2**  
 D 150/190/530/636  
 4/86

<b>27</b> <b>17/2</b>		4/86					D 150	D 190	D 530	D 636		
Nr.	Teile-Nummer	Symbol	Benennung							Bemerkung		
19	07 11 9913 644		6 KT SHR M 8 × 20	1	1	1	1					
20	27 63 1 331 264		Schalthebel / Gear shift lever / Levier de commande / Växelspak / Leva di comando	1	1	1	1					
21	07 11 9922 087		6 KT MU M 8	4	4	4	4					
22	a b 27 63 1 761 951		kpI. Ölmeßstab / Dipstick / Jauge d'huile / Oljemätssticka / Asta controllo livello olio	1	1	1	1					
	c 27 63 1 763 033		dito	1	1	1	1					
23	07 11 9919 016		VSL SHR M 16 × 1,5	2	2	2	2					

a) Nur für HBW 360 / For HBW 360 only / Uniquement pour HBW 360 / Bara för HBW 360 / Solo per HBW 360  
 b) Nur für HBW 360 A / For HBW 360 A only / Uniquement pour HBW 360 A / Bara för HBW 360 A / Solo per HBW 360 A  
 c) Nur für HBW 450 / For HBW 405 only / Uniquement pour HBW 405 / Bara för HBW 450 / Solo per HBW 405

V12 Engineering  
 www.bmwmarine.com

Hurth HBW 360 / 360 A / 450  
 Hurth HBW 360 / 360 A / 450  
 Hurth HBW 360 / 360 A / 450  
 Hurth HBW 360 / 360 A / 450  
 Hurth HBW 360 / 360 A / 450

BMW D 150 / D 190 / D 530 / D 636

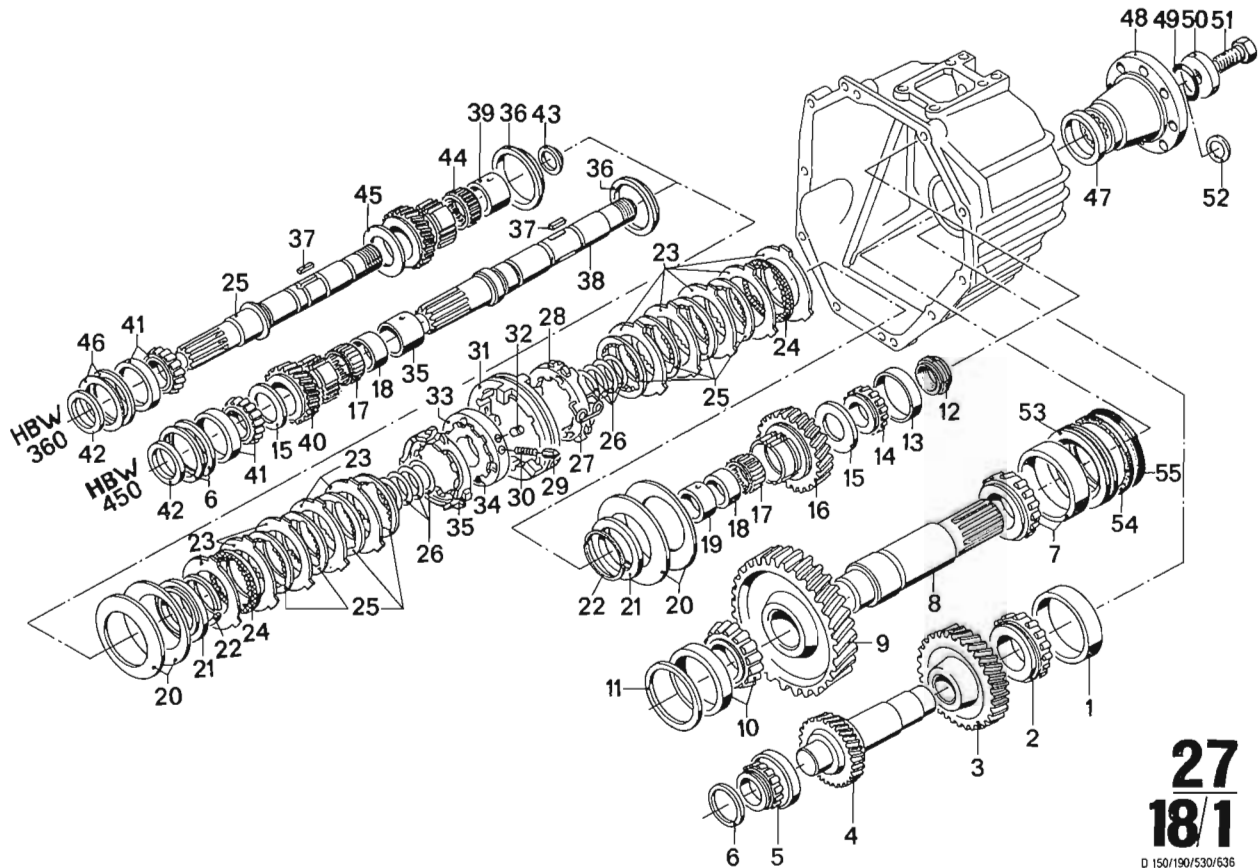

D 150/190/530/636  
4/86

27/18/1		4/86						
Nr.	Teile-Nummer	Symbol	Benennung	D 150	D 190	D 530	D 636	Bemerkung
1	a b 27 62 1 328 390		Kegelrollenlager / Tapered roller bearing / Roulement à rouleaux / Koniskt rullager / Cusc. a rulli conici	1	1	1	1	
	c 07 119 985 082		dito	1	1	1	1	
2	a b 27 62 1 328 389		dito	1	1	1	1	
3	a 27 63 1 761 992		Z 35 Zahnrad / Toothed wheel / Roue dentée / Kugghjul / Ruota dentata	1	1	1	1	
4	a 27 63 1 761 959		Z 24 Ritzelwelle / Pinion shaft / Arbre de pignon / Kugghjulsaxel / Albero del pignone	1	1	1	1	i = 1,5:1
	a 27 63 1 761 960		Z 32 dito	1	1	1	1	i = 2,0:1
	a 27 63 1 761 961		Z 21 dito	1	1	1	1	i = 3,0:1
	b 27 63 1 761 067		Z 32 dito	1	1	1	1	i = 1,5:1
	b 27 63 1 761 068		Z 24 dito	1	1	1	1	i = 2,0:1
	b 27 63 1 761 069		Z 20 dito	1	1	1	1	i = 3,0:1
	c 27 63 1 763 013		Z 25 dito	1	1	1	1	i = 1,5:1
	c 27 63 1 763 014		Z 30 dito	1	1	1	1	i = 2,0:1
	c 27 63 1 763 012		Z 19 dito	1	1	1	1	i = 3,0:1
5	a b 27 63 1 761 994		Kegelrollenlager / Tapered roller bearing / Roulement à rouleaux / Koniskt rullager / Cusc. a rulli conici	1	1	1	1	
	c 27 63 1 761 015		dito	1	1	1	1	
6	a b 27 63 1 761 962		0,1 Scheibe / Washer / Rondelle / Bricka / Rondella	1	1	1	1	
	a b 27 63 1 761 963		0,15 dito	1	1	1	1	
	a b 27 63 1 761 964		0,20 dito	1	1	1	1	
	a b 27 63 1 761 965		0,50 dito	1	1	1	1	
	a b 27 63 1 761 966		1,00 dito	1	1	1	1	
	c 27 62 1 328 222		0,10 dito	2	2	2	2	
	c 27 62 1 328 223		0,15 dito	2	2	2	2	
	c 27 62 1 328 224		0,20 dito	2	2	2	2	
	c 27 62 1 328 225		0,50 dito	2	2	2	2	
	c 27 62 1 328 226		1,00 dito	2	2	2	2	
7	a 27 63 1 761 996		Kegelrollenlager / Tapered roller bearing / Roulement à rouleaux / Koniskt rullager / Cusc. a rulli conici	1	1	1	1	
	b 27 63 1 763 075		dito	1	1	1	1	
	c 27 63 1 763 020		dito	1	1	1	1	

a) Nur für HBW 360 / For HBW 360 only / Uniquement pour HBW 360 / Bara för HBW 360 / Solo per HBW 360  
 b) Nur für HBW 360 A / For HBW 360 A only / Uniquement pour HBW 360 A / Bara för HBW 360 A / Solo per HBW 360 A  
 c) Nur für HBW 450 / For HBW 405 only / Uniquement pour HBW 405 / Bara för HBW 450 / Solo per HBW 450

V12 Engineering

www.bitwitalie.com

Hurth HBW 360 / 360 A / 450  
 Hurth HBW 360 / 360 A / 450  
 Hurth HBW 360 / 360 A / 450  
 Hurth HBW 360 / 360 A / 450  
 Hurth HBW 360 / 360 A / 450

BMW D 150 / D 190 / D 530 / D 636

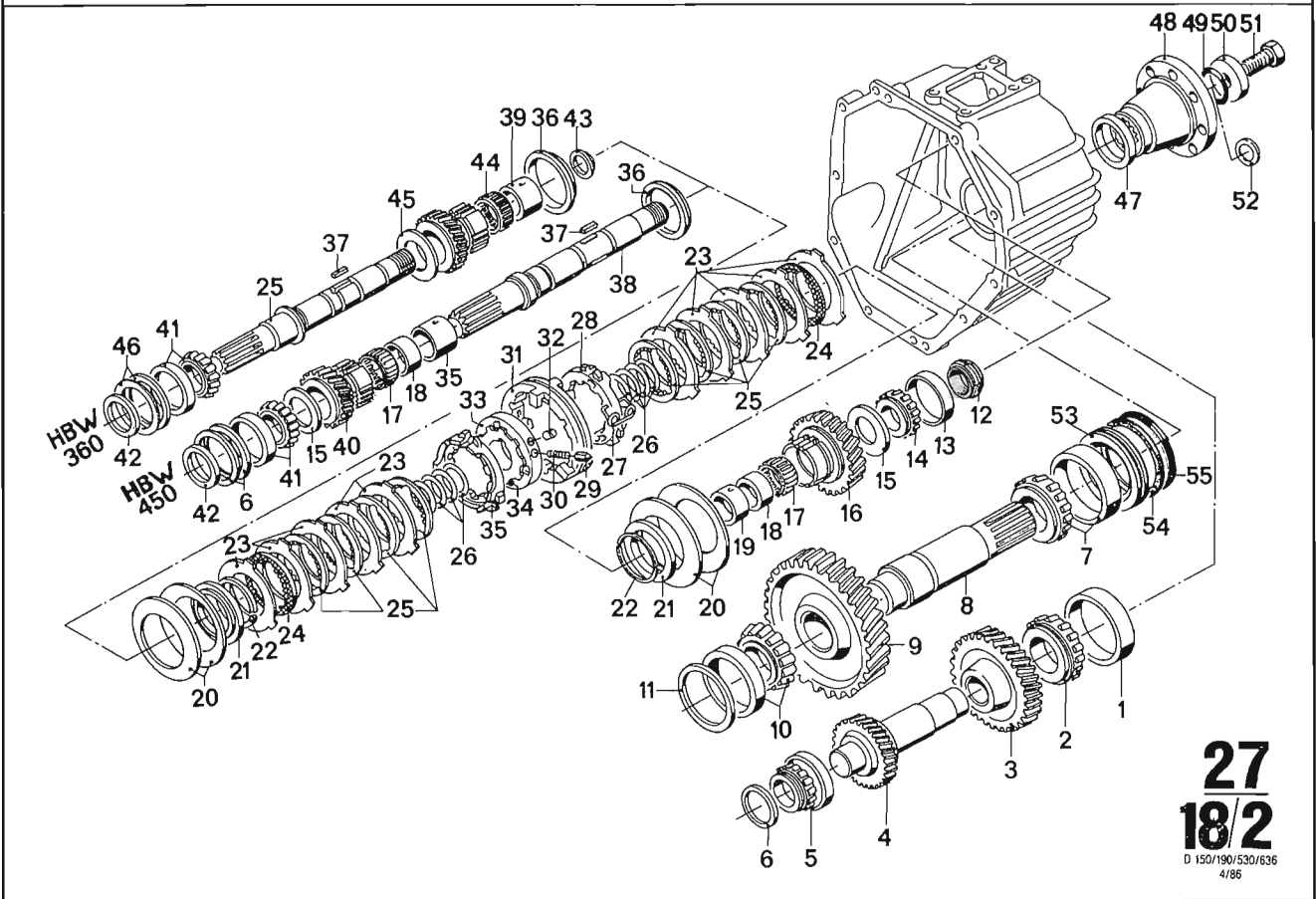

**27**  
**18/2**  
 D 150/190/530/636  
 4/86

27 18/2		4/86							
Nr.	Teile-Nummer	Symbol	Benennung	D 150	D 190	D 530	D 636	Bemerkung	
8	a 27 63 1 761 953		Abtriebswelle / Output shaft / Arbre de sortie / Drevaxel / Albero di trasmissione	1	1	1	1		
	b 27 63 1 763 070		dito	1	1	1	1		
	c 27 63 1 763 006		dito	1	1	1	1		
9	a 27 63 1 761 967		Z 49 Abtriebszahnrad / Output gear wheel / Roue dentée de sortie / Drivjet kuggjul / Ruota dentata condotta	1	1	1	1	i = 1,5:1	
	a 27 63 1 761 968		Z 59 dito	1	1	1	1	i = 2,0:1	
	a 27 63 1 761 969		Z 49 dito	1	1	1	1	i = 3,0:1	
	b 27 63 1 763 071		Z 51 dito	1	1	1	1	i = 1,5:1	
	b 27 63 1 763 072		Z 51 dito	1	1	1	1	i = 2,0:1	
	b 27 63 1 763 073		Z 61 dito	1	1	1	1	i = 3,0:1	
	c 27 63 1 763 016		Z 48 dito	1	1	1	1	i = 1,5:1	
	c 27 63 1 763 017		Z 53 dito	1	1	1	1	i = 2,0:1	
	c 27 63 1 763 018		Z 59 dito	1	1	1	1	i = 3,0:1	
10	27 63 1 761 995		Kegelrollenlager / Tapered roller bearing / Roulement à rouleaux / Koniskt rullager / Cusc. a rulli conici	1	1	1	1		
	b 27 63 1 763 074		dito	1	1	1	1		
	c 27 63 1 763 019		dito	1	1	1	1		
11	a 27 63 1 761 954		0,1 Ausgleichscheibe / Compensation shim / Disque de compensation / Mellanlägg / Rondella di spessore	1	1	1	1		
	a 27 63 1 761 955		0,15 dito	1	1	1	1		
	a 27 63 1 761 956		0,20 dito	1	1	1	1		
	a 27 63 1 761 957		0,50 dito	1	1	1	1		
	a 27 63 1 761 958		1,00 dito	1	1	1	1		
	b 27 63 1 763 086		0,1 dito	1	1	1	1		
	b 27 63 1 763 087		0,15 dito	1	1	1	1		
	b 27 63 1 763 088		0,30 dito	1	1	1	1		
	b 27 63 1 763 089		0,50 dito	1	1	1	1		
	c 27 63 1 763 007		0,1 dito	1	1	1	1		
	c 27 63 1 763 008		0,15 dito	1	1	1	1		
	c 27 63 1 763 009		0,30 dito	1	1	1	1		
	c 27 63 1 763 010		0,5 dito	1	1	1	1		

a) Nur für HBW 360 / For HBW 360 only / Uniquement pour HBW 360 / Bara för HBW 360 / Solo per HBW 360  
 b) Nur für HBW 360 A / For HBW 360 A only / Uniquement pour HBW 360 A / Bara för HBW 360 A / Solo per HBW 360 A  
 c) Nur für HBW 450 / For HBW 405 only / Uniquement pour HBW 405 / Bara för HBW 450 / Solo per HBW 450

V12 Engineering  
 www.bmwmarine.com



Hurth HBW 360 / 360 A / 450  
 Hurth HBW 360 / 360 A / 450  
 Hurth HBW 360 / 360 A / 450  
 Hurth HBW 360 / 360 A / 450  
 Hurth HBW 360 / 360 A / 450

BMW D 150 / D 190 / D 530 / D 636

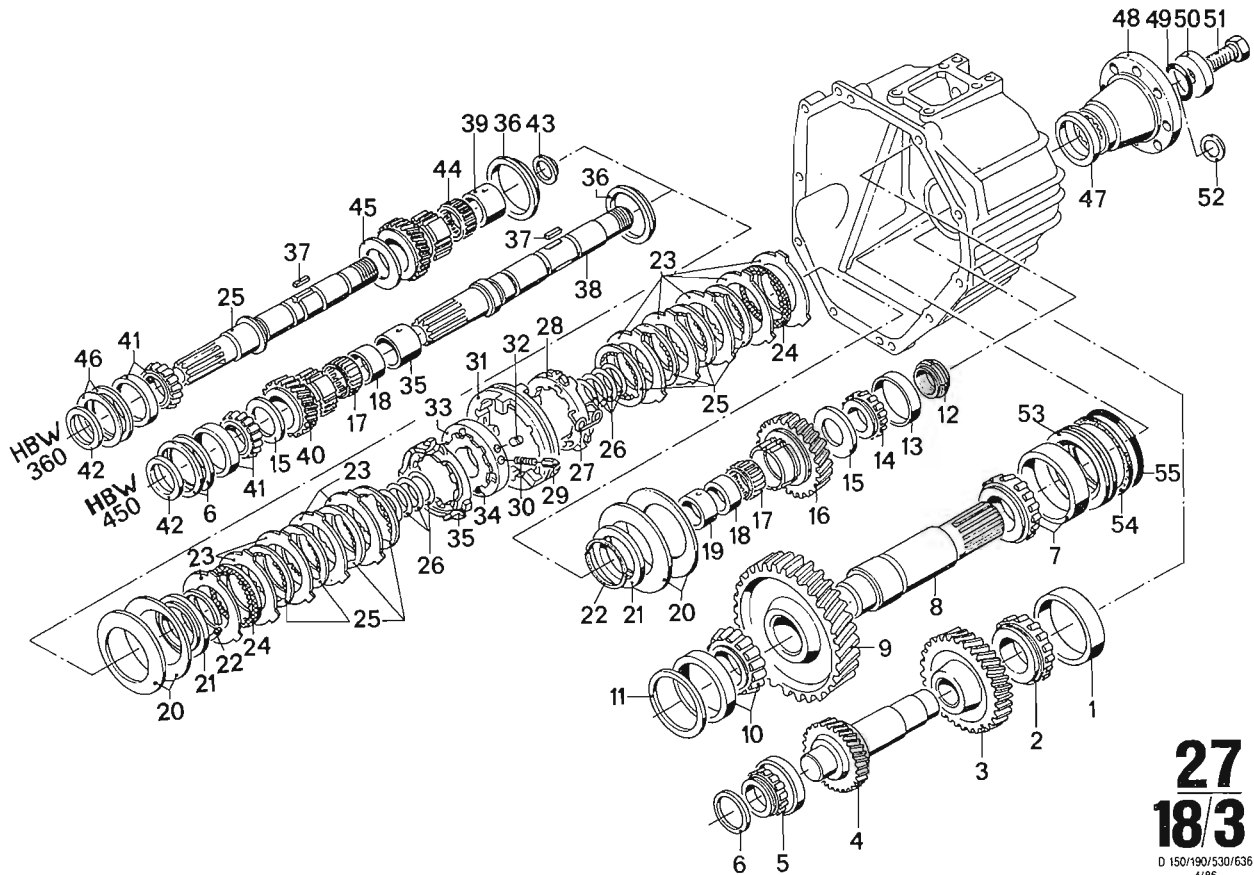

**27**  
**18/3**  
 D 150/190/530/636  
 4/86

27 18/3		4/86									
Nr.	Teile-Nummer	Symbol	Benennung	D 150	D 190	D 530	D 636	Bemerkung			
12	27 63 1761 974		Nutmutter / Grooved nut / Ecrou cannelé / Ringmutter med spår / Ghiera	1	1	1	1				
13	a b 27 62 1328 408		Kegelrollenlager / Tapered roller bearing / Roulement à rouleaux / Koniskt rullager / Cusc. a rulli conici	1	1	1	1				
	c 27 62 1328 391		dito	1	1	1	1				
14	a b 27 62 1328 409		dito	1	1	1	1				
	c 27 63 1763 030		dito	1	1	1	1				
15	27 63 1761 984		Anlaufscheibe / Thrust washer / Rondelle d'entraînement / Passbricka / Rosetta di arresto	1	1	1	1				
16	a b 27 63 1761 970		Z 34 Zahnrad / Toothed wheel / Roue dentée / Kuggjul / Ruota dentata	1	1	1	1				
	c 27 63 1763 021		Z 36 dito	1	1	1	1				
17	27 62 1330 602		Nadelkäfig / Needle cage / Cage de palier à aiguilles / Nalbur / Gabbia ad aghi	1	1	1	1				
18	27 62 1328 181		Nadellager-Innenring / Needle roller bearing inner ring / Bague intérieure de roulement à aiguilles / Nällager-innerring Anello interno cuscinetto ad aghi	1	1	1	1				
19	a b 27 63 1761 982		Abstandsbuchse / Spacer bushing / Douille d'écartement / Avståndsbussning / Nottolino d'arresto	1	1	1	1				
	c 27 63 1763 028		dito	1	1	1	1				
20	27 63 1761 975		Tellerfeder / Diaphragm spring / Ressort belleville / Tallriksfjäder / Molla di disco	4	4	4	4				
21	27 63 1761 977		Endlamelle / Disc / Lamelle terminale / Aendlamell / Lamella terminale	1	1	1	1				
22	27 63 1761 983		Ringhälfte / Ring half / Moitié d'anneau / Ringhalva / Metà anello	2	2	2	2				
23	27 63 1761 978		Aussenlamelle / Outer disk / Disque extérieur / Ytterlamell / Lamella esterna	4	4	4	4				
24	27 63 1761 989		Innenlamelle / Inner disk / Disque intérieur / Inner lamell / Lamella interna	2	2	2	2				
25	27 62 1328 178		dito	6	6	6	6				
26	27 62 1328 174		0,4 Ausgleichsscheibe / Compensation shim / Disque de compensation / Mellanlägg / Rondella di spessore	2	2	2	2				
	27 62 1328 175		0,5 dito	1	1	1	1				
	27 62 1328 176		0,6 dito	1	1	1	1				
	27 62 1328 177		0,7 dito	1	1	1	1				
27	27 63 1761 988		Drehfeder / Torsion spring / Barre de torsion / Dragfjäder / Molla girevole	3	3	3	3				

a) Nur für HBW 360 / For HBW 360 only / Uniquement pour HBW 360 / Bara för HBW 360 / Solo per HBW 360  
 b) Nur für HBW 360 A / For HBW 360 A only / Uniquement pour HBW 360 A / Bara för HBW 360 A / Solo per HBW 360 A  
 c) Nur für HBW 450 / For HBW 405 only / Uniquement pour HBW 405 / Bara för HBW 450 / Solo per HBW 450

Hurth HBW 360 / 360 A / 450  
 Hurth HBW 360 / 360 A / 450  
 Hurth HBW 360 / 360 A / 450  
 Hurth HBW 360 / 360 A / 450

BMW D 150 / D 190 / D 530 / D 636

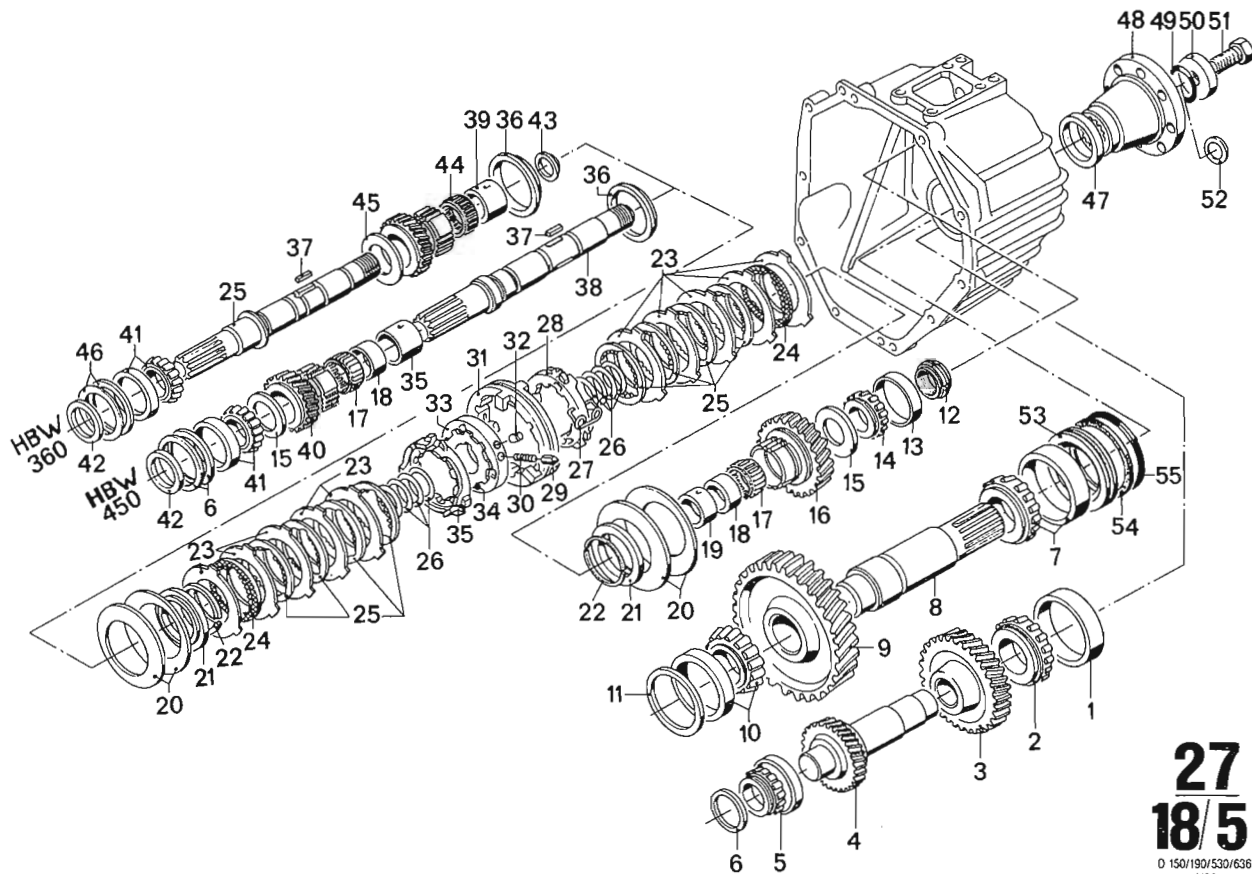

**27**  
**18/5**  
 O 150/190/530/636  
 4/86

27 18/5		4/86										
Nr.	Teile-Nummer	Symbol	Benennung	D 150	D 190	D 530	D 636					Bemerkung
41	a b 07 119 985 082		Kegelrollenlager / Tapered roller bearing / Roulement à rouleaux / Koniskt rullager / Cusc. a rulli conici	1	1	1	1					
	c 27 63 1 761 015		dito	1	1	1	1					
42	a b 27 63 1 761 946		DTRG	1	1	1	1					
	c 27 63 1 761 463		dito	1	1	1	1					
43	a 27 63 1 761 991		Winkelringhälfte / Grooved face type ring half / Moitié de cornière angulaire / Vinkelringhalva / Metà anello angolare	1	1	1	1					
44	a b 27 63 1 761 944		Nadelkäfig / Needle cage / Cage de palier à aiguilles / Nalbur / Gabbia ad aghi	1	1	1	1					
45	a 27 63 1 761 987		Anlaufscheibe / Thrust washer / Rondelle d'entraînement / Passbricka / Rosetta di arresto	1	1	1	1					
46	a b 27 63 1 763 222		0,1 Ausgleichsscheibe / Compensation shim / Disque de compensation / Mellanlägg / Rondella di spessore	1	1	1	1					
	a b 27 63 1 763 223		0,15 dito	1	1	1	1					
	a b 27 63 1 763 224		0,30 dito	1	1	1	1					
	a b 27 63 1 763 225		0,50 dito	1	1	1	1					
	a b 27 63 1 763 226		1,00 dito	1	1	1	1					
47	a c 27 63 1 761 948		DTRG	1	1	1	1					
	b 27 63 1 761 077		dito	1	1	1	1					
48	27 63 1 761 936		Flansch / Flange / Bride / Fläns / Flangia	1	1	1	1					
49	a c 27 63 1 761 949		O-Ring / O-ring / Joint torique / O-ring / Anello-O	1	1	1	1					
	b 27 63 1 763 076		dito	1	1	1	1					
50	27 63 1 761 950		Scheibe / Washer / Rondelle / Bricka / Rondella	1	1	1	1					
51	07 119 913 908		6 KT SHR M 12 x 40	1	1	1	1					
52	b 27 63 1 763 081		0,1 Ausgleichsscheibe / Compensation shim / Disque de compensation / Mellanlägg / Rondella di spessore	1	1	1	1					
	b 27 63 1 763 082		0,15 dito	1	1	1	1					
	b 27 63 1 763 085		0,50 dito	1	1	1	1					
	b 27 63 1 763 084		1,00 dito	1	1	1	1					
53	b 27 63 1 763 078		Wellenschutz / Shaft protector / Protection d'arbre / Axelskydd / Protezione albero	1	1	1	1					
54	b 27 63 1 763 076		O-ring / O-ring / Joint torique / O-ring / Anello-O	1	1	1	1					
55	b 27 63 1 763 080		Sprengring / Retaining ring / Rondelle Grower / Stopping / Anello elastico	1	1	1	1					

a) Nur für HBW 360 / For HBW 360 only / Uniquement pour HBW 360 / Bara för HBW 360 / Solo per HBW 360  
 b) Nur für HBW 360 A / For HBW 360 A only / Uniquement pour HBW 360 A / Bara för HBW 360 A / Solo per HBW 360 A  
 c) Nur für HBW 450 / For HBW 405 only / Uniquement pour HBW 405 / Bara för HBW 450 / Solo per HBW 450

V12 Engineering

Hurth HBW 360 / 360 A / 450  
 Hurth HBW 360 / 360 A / 450  
 Hurth HBW 360 / 360 A / 450  
 Hurth HBW 360 / 360 A / 450

BMW D 150 / D 190 / D 530 / D 636

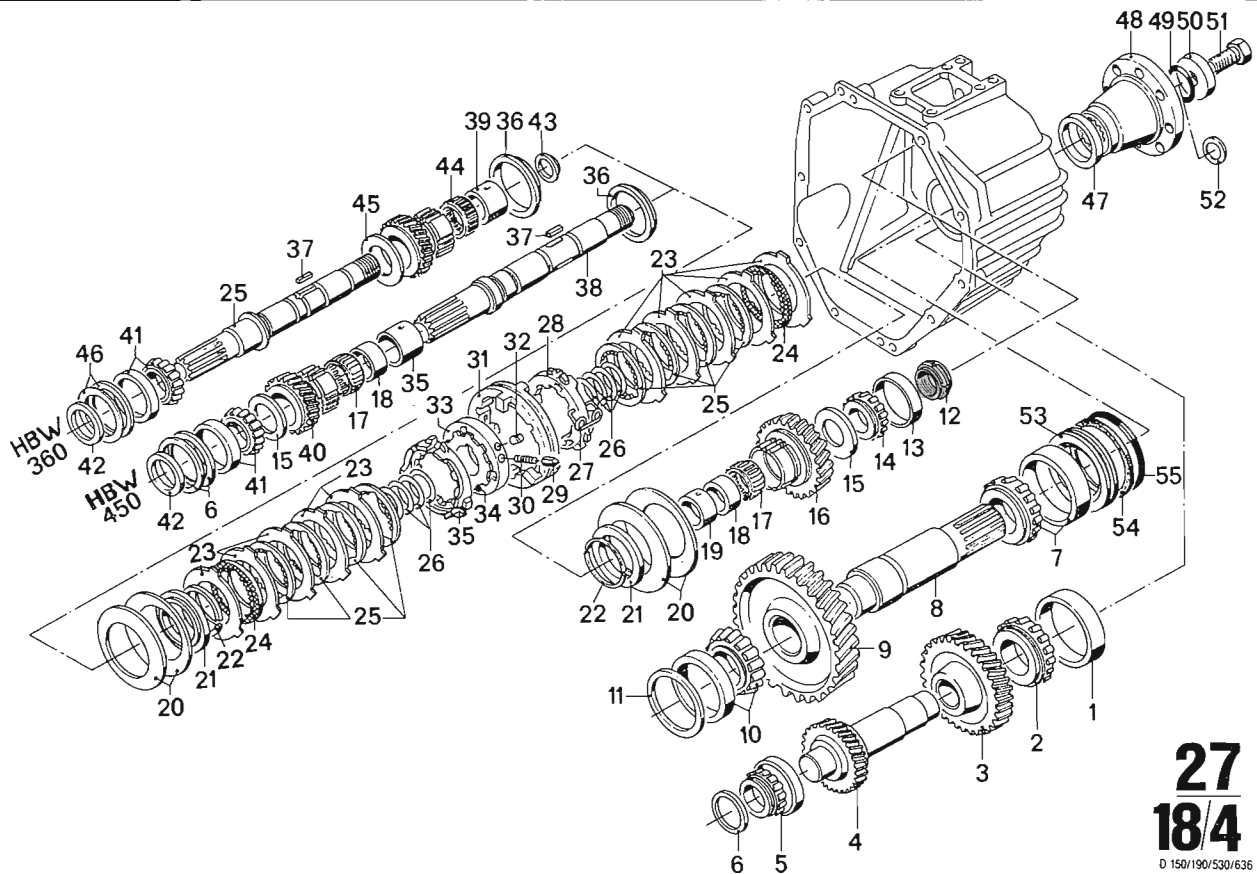

**27**  
**18/4**  
 D 150/190/530/636  
 4/86

<b>27</b> <b>18/4</b>												
						D 150	D 190	D 530	D 636			
Nr.	Teile-Nummer	Symbol	Benennung				Bemerkung					
28	a b 27 63 1 761 985	R	Lamellenträger / Disk carrier / Support de disque / Lamellhållare / Portalamella				1	1	1	1		
	c 27 63 1 763 034	R	dito				1	1	1	1		
29	27 62 1 328 202		Arretierstift / Retaining pin / Cheville d'arrêt / Läspinne / Bullone d'arresto				3	3	3	3		
30	27 62 1 328 162		Druckfeder / Compression spring / Ressort de pression / Tryckfjäder / Molla di compressione				3	3	3	3		
31	27 62 1 328 205		Schaltmuffe / Gear shift sleeve / Douille de commande / Kopplingsmuff / Manicotto di comando				1	1	1	1		
32	27 62 1 328 203		Mitnehmerstift / Driving pin / Broche d'entraînement / Medbringarstift / Perno di trascinamento				3	3	3	3		
33	a b 27 63 1 761 980		Führungsmuffe / Guide sleeve / Douille de guidage / Styrnuff / Manicotto d. guida				1	1	1	1		
	c 27 63 1 763 026		dito				1	1	1	1		
	07 11 9 986 298		Ø 9 Kugel / Ball / Bille / Kula / Sfera				6	6	6	6		
35	a b 27 63 1 761 979	L	Lamellenträger / Disk carrier / Support de disque / Lamellhållare				1	1	1	1		
	c 27 63 1 763 025	L	dito				1	1	1	1		
36	27 63 1 761 939		Stützring / Support ring / Anneau d'appui / Stödtring / Anello di sostegno				1	1	1	1	i = 1,5 + 2,0:1	
	27 63 1 761 940		dito				2	2	2	2	i = 3,0:1	
	27 63 1 761 976		Paßfeder / Feather key / Ressort d'ajustage / Passkil / Chiavetta a molla d'adattam.				2	2	2	2		
38	a b 27 63 1 761 947		Antriebswelle / Drive shaft / Arbre de commande / Motoraxel / Albero primario				1	1	1	1		
	c 27 63 1 763 005		dito				1	1	1	1		
39	a b 27 63 1 761 981		Distanzbuchse / Spacer socket / Douille d'écartement / Distanshylsa / Boccia distanziatore				1	1	1	1		
	c 27 63 1 763 027		dito				1	1	1	1		
40	a 27 63 1 761 971		Z 20 Zahnrad / Toothed wheel / Roue dentée / Kuggghjul / Ruota dentata				1	1	1	1	i = 1,5:1	
	a 27 63 1 761 972		Z 23 dito				1	1	1	1	i = 2,0:1	
	a 27 63 1 761 973		Z 31 dito				1	1	1	1	i = 3,0:1	
	c 27 63 1 763 022		Z 20 dito				1	1	1	1	i = 1,5:1	
	c 27 63 1 763 023		Z 26 dito				1	1	1	1	i = 2,0:1	
	c 27 63 1 763 024		Z 31 dito				1	1	1	1	i = 3,0:1	

a) Nur für HBW 360 / For HBW 360 only / Uniquement pour HBW 360 / Bara för HBW 360 / Solo per HBW 360  
 b) Nur für HBW 360 A / For HBW 360 A only / Uniquement pour HBW 360 A / Bara för HBW 360 A / Solo per HBW 360 A  
 c) Nur für HBW 450 / For HBW 405 only / Uniquement pour HBW 405 / Bara för HBW 450 / Solo per HBW 405

V12 Engineering  
 www.bmwmarine.com

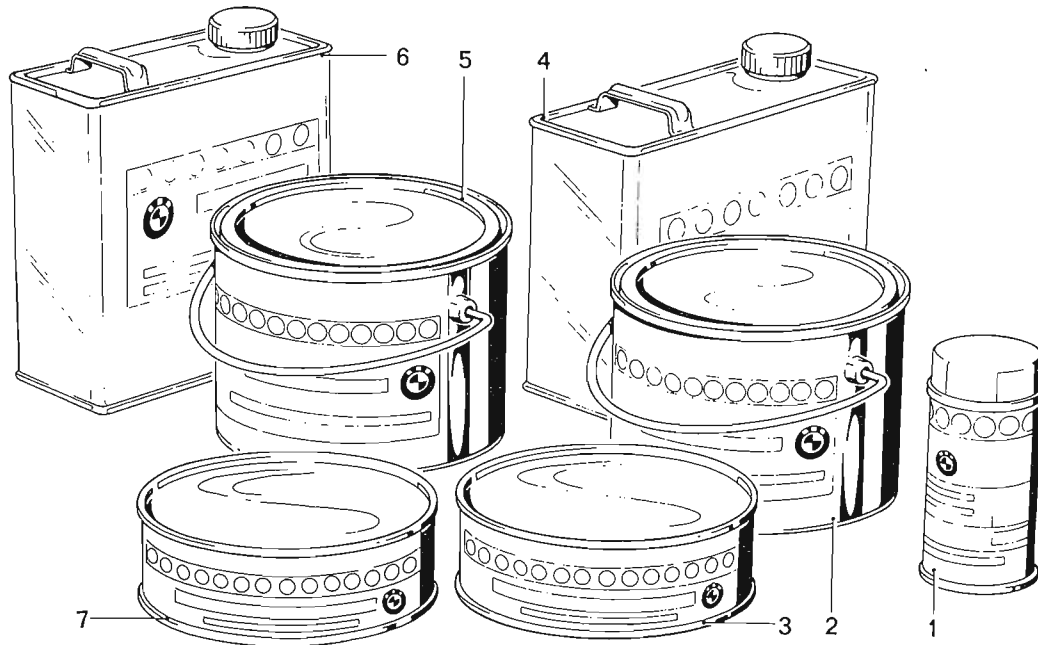

**51**  
**1**

D 150/190/530/636  
4/86

<b>51</b> <b>1</b>		4/86		D 150	D 190	D 530	D 636	
Nr.	Teile-Nummer	Symbol	Benennung					Bemerkung
1	a 51 91 1 330 467		400 ML Spray-silbergrau / Silver grey spray / Bombe aérosol / gris argent / Spray i silbergrå / Spray grigio-argento	X	X	X	X	
2	b 51 91 1 330 468		5000 ML silbergrau / silver grey / gris argent / silvergrå / grigio-argento	X	X	X	X	
3	c 51 91 1 330 469		2000 ML Härter / Hardener / Durcisseur / Härdningsmedel / Induritore	X	X	X	X	
4	51 91 1 330 470		5000 ML Verdünner / Thinner / Diluant / Utspädningsmedel / Diluente	X	X	X	X	
5	51 91 1 330 471		5000 ML Primer / Primer / Primer / Primer / Primer	X	X	X	X	
6	51 91 1 330 502		5000 ML Verdünner für Primer / Thinner for primer / Diluant pour primer / Utspädningsmedel för primer / Diluente per primer	X	X	X	X	
7	d 51 91 1 330 481		2000 ML Härter für Primer / Hardener for primer / Durcisseur p. primer / Härdningsmedel för primer / Induritore per primer	X	X	X	X	

- a) Einkomponentenlack / Single-component varnish / Laque a une composante / Lack med 1 komponent / Vernice ad una componente  
 b) Zweikomponentenlack / Two-component varnish / Laque a deux composantes / Lack med 2 komponenter / Vernice a due componenti  
 c) n.i.V.m. Pos. 2  
 d) n.i.V.m. Pos. 5



Instrumententafel – Idea  
 Instrument panel – Idea  
 Tableau des instruments – Idea  
 Instrumenttavla – Idea  
 Cruscotto – Idea

BMW D 150 / D 190 / D 530 / D 636

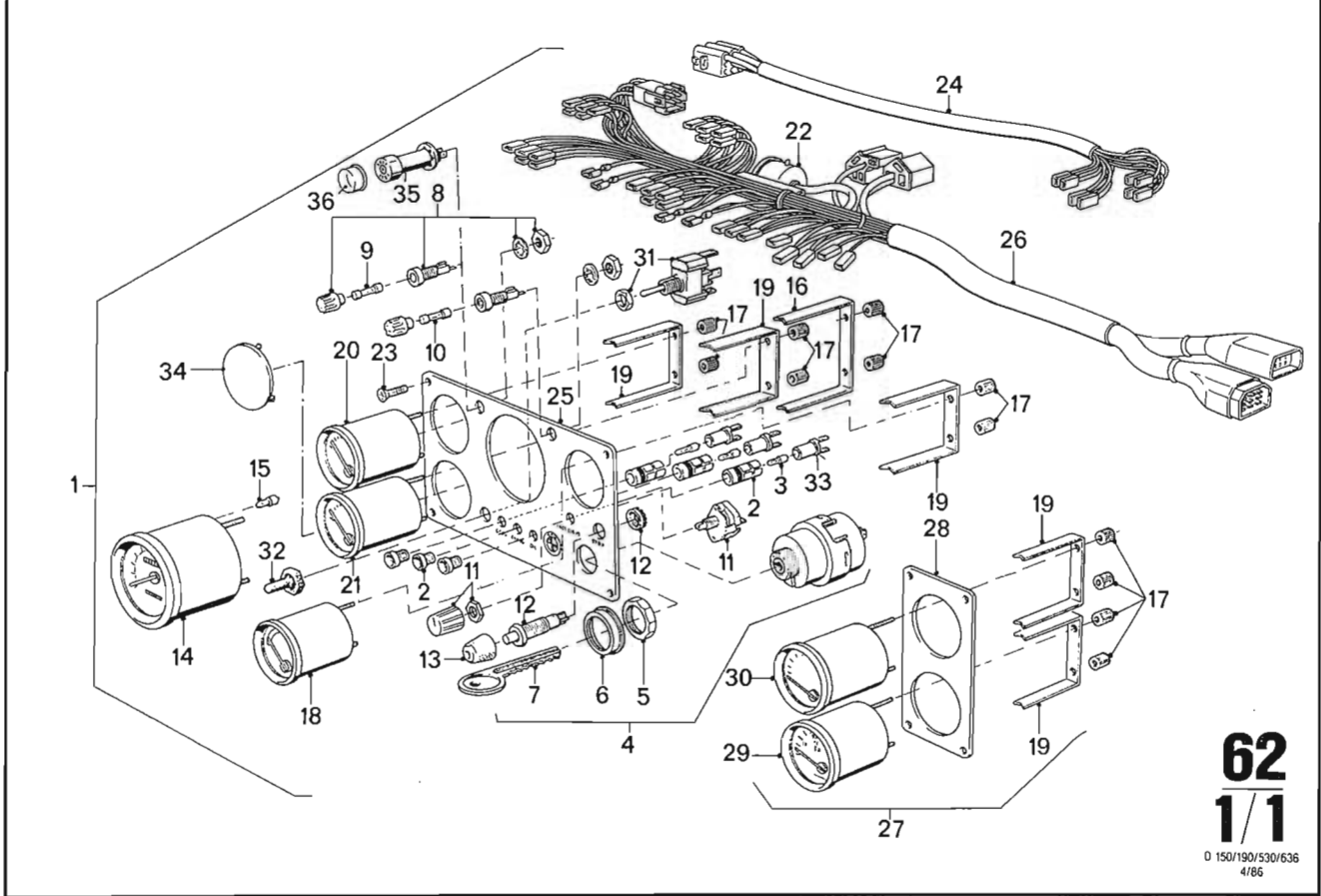

**62**  
**1/1**

D 150/190/530/636  
4/86

62 1/1		4/86																				
Nr.	Teile-Nummer	Symbol	Benennung										D 150	D 190	Bemerkung							
1	a 62 10 1 334 066 b 62 10 1 331 981 c 62 10 1 334 052		kpl. Instrumententafel / Instrument panel / Tableau des instruments / Instrumenttavla / Cruscotto										1	1								
2	62 14 8 648 136		Kontrolleuchte / Telltale lamp / Lampe témoin / Kontrollampa / Spia luminosa										3	1								
3	07 11 9 978 256		HL 12 V – 4 W Glühlampe / Bulb / Ampoule / Glödlampa / Lampada a incandescenza										3	3								
4	61 32 1 331 960		kpl. Zündanlaßschalter / Ignition starter switch / Commutateur de démarreur / Tändstartkontakt / Interruttore d'avviamento										1	1								
5	61 32 1 331 971		6 KT MU										1	1								
6	61 32 1 331 972		Schutzkappe / Protection cap. / Capot de protection / Skyddskåpa / Cappelot. d. protezione										1	1								
7	61 32 1 333 975		Zündschlüssel-Rohling / Ignition key blank / Clé de contact-brute / Råämne för tändnyckel / Spezzone chiavetta d'accensione										X	X								
8	61 13 1 328 974		Sicherungsschalter / Safety switch / Commutateur de coupe-circuit / Säkringsströmställare / Interruttore di sicurezza										2	2								
9	61 13 1 331 916		8 A Feinsicherung / Precision fuse / Fusible fin / Finsäkring / Bloccaggio di precisione										1	1								
10	61 10 1 331 949		15 A dito										1	1								
11	61 31 1 331 910		Potentiometer / Potentiometer / Potentiomètre / Potentiometer / Potentiometer										1	1								
12	61 13 1 333 902		Drucktaster-Motorstop / Pushbutton-engine stop / Touche d'arrêt du moteur / Trycktangent för motorstopp / Pulsante a tasto per l'arresto del motore										1									
13	61 31 1 333 903		Schutzkappe / Protection cap / Capot de protection / Skyddskåpa / Cappelot. d. protezione										1	1								
14	62 13 1 331 963		kpl. Drehzahlmesser / Tachometer / Compte-tours / Varvtalsmätare / Contagiri										1	1								
15	07 11 9 978 254		H 12 V – 2 W Glühlampe / Bulb / Ampoule / Glödlampa / Lampada a incandescenza										1	1								

a) Nur für Wendegetriebe / For reversing gearbox only / Uniquement pour réducteur-inverseur / Bara för backväxel / Solo per cambio ad inversione di marcia  
 b) → Aggr. Nr. 653 (D150) → Aggr. Nr. 6039 (D190)  
 c) Aggr. Nr. → dito

V12 Engineering  
www.bmwmarine.com

V12 Engineering  
Box 50, Ontario, Canada P0X 1X0  
www.bmwmarine.net

Instrumententafel – Idea  
 Instrument panel – Idea  
 Tableau des instruments – Idea  
 Instrumenttavla – Idea  
 Cruscotto – Idea

BMW D 150 / D 190 / D 530 / D 636

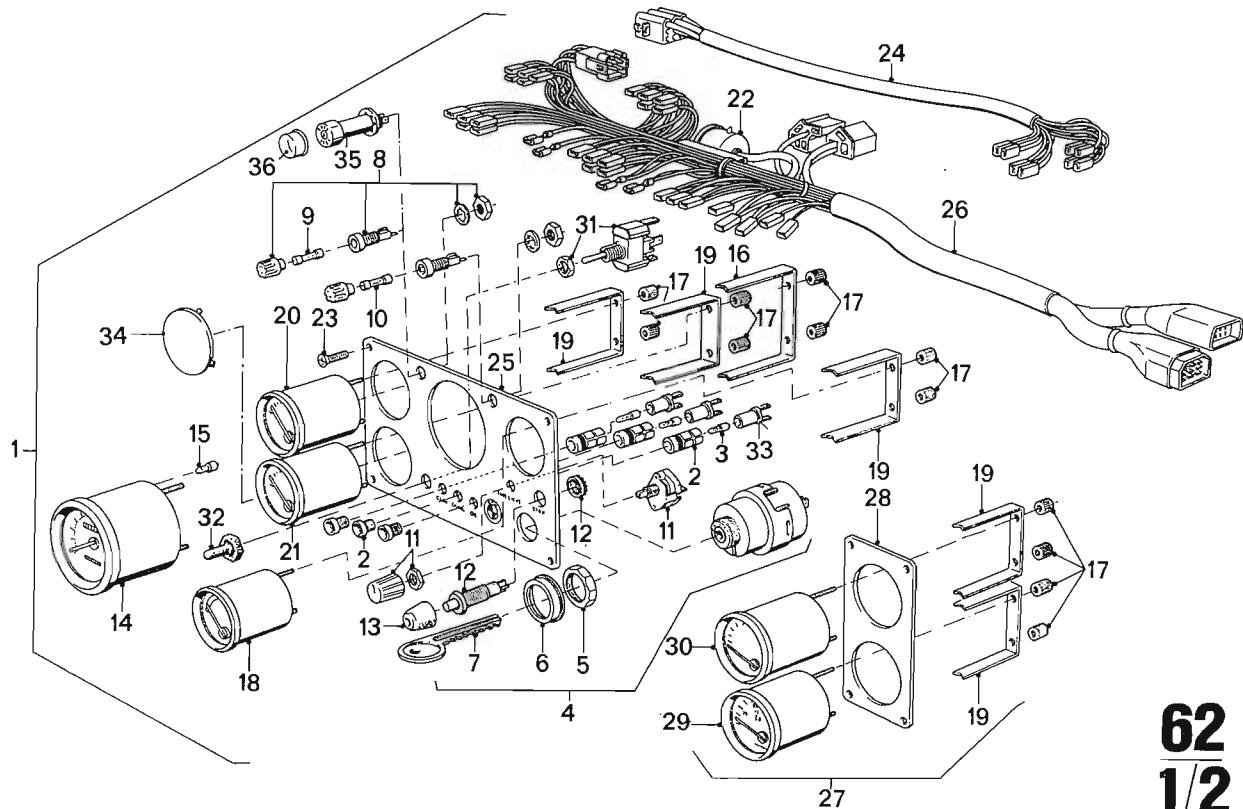

**62**  
**1/2**  
 D 150/D 190  
 4/86

<b>62</b> <b>1/2</b>		4/86				D 150	D 190			Bemerkung
Nr.	Teile-Nummer	Symbol	Benennung							
16	62 13 1 331 965		Befestigungsbügel / Mounting clamp / Etrier de fixation / Infästningsbygel / Staffa di fissaggio			1	1			
17	62 13 1 331 970		Rändelmutter / Knurled nut / Ecrou moleté / Råfflad mutter / Dado zigrinato			12	12			
18	62 13 1 331 967		kpl. Voltmeter / Voltmeter / Voltmètre / Voltmeter / Voltmetro			1	1			
19	62 13 1 331 969		Befestigungsbügel / Mounting clamp / Etrier de fixation / Infästningsbygel / Staffa di fissaggio			5	5			
20	62 13 1 331 989		kpl. Wasserthermometer / Water thermometer / Thermomètre d'eau / Vattenthermometer / Termometro per acqua			1	1			
21	62 13 1 331 991		kpl. Trimmanzelge / Trim indicator / Indicateur de trim / Trimindikator / Indicatore di trim			1	1			
22	61 31 1 243 490		Summer / Buzzer / Ronfleur / Summer / Cicalino			1	1			
23	07 11 9 902 520		B 4,2 x 16 BL SHR			8	8			
24	61 11 1 331 995		Kabelbaum-Teilstück / Cable harness-component / Faisceau de câbles – élément partiel / Kabelstam-delstycke / Fascio de cavi parziale			1	1			
25	b 62 11 1 331 987		Instrumententafel / Instrument panel / Tableau des instruments / Instrumenttavla / Cruscotto			1				
	c 62 11 1 334 065		dito			1	1			
26	b 61 11 1 331 985		Kabelbaum-Instrumente / Cable harness-instruments / Faisceau de câbles – instruments / Kabelstam-instrument / Cavi fasciati – strumenti			1				
	c 61 11 1 334 053		dito			1	1			
27	62 11 1 331 996		kpl. Zusatzinstrumententafel / Auxiliary instrument panel / Tableau d'instruments complémentaire / Tillsatsinstrumentpanel Cruscotto supplementare			1	1			
28	62 11 1 331 997		Instrumententafel / Instrument panel / Tableau des instruments / Instrumenttavla / Cruscotto			1	1			
29	62 13 1 331 998		kpl. Ölthermometer / Oil thermometer / Thermomètre d'huile / Oljetermometer / Indicatore temperatura dell'olio			1	1			
30	62 13 1 331 973		kpl. Öldruckmesser / Oil pressure gauge / Manomètre d'huile / Oljetrycksmätare / Manometro pressione olio			1	1			
31	61 31 1 333 992		kpl. Kipptaster / Toggle switch / Interrupteur à bascule / Vipptangent / Interruttore a bilanciere			1	1			

a) Nur für Wendegetriebe / For reversing gearbox only / Uniquement pour réducteur-inverseur / Bara för backväxel / Solo per cambio ad inversione di marcia  
 b) → Aggr. Nr. 653 (D150) → Aggr. Nr. 6039 (D190)  
 c) Aggr. Nr. — dito

V12 Engineering

www.bmwmarine.com

Instrumententafel – Idea  
 Instrument panel – Idea  
 Tableau des instruments – Idea  
 Instrumenttavla – Idea  
 Cruscotto – Idea

BMW D 150 / D 190 / D 530 / D 636

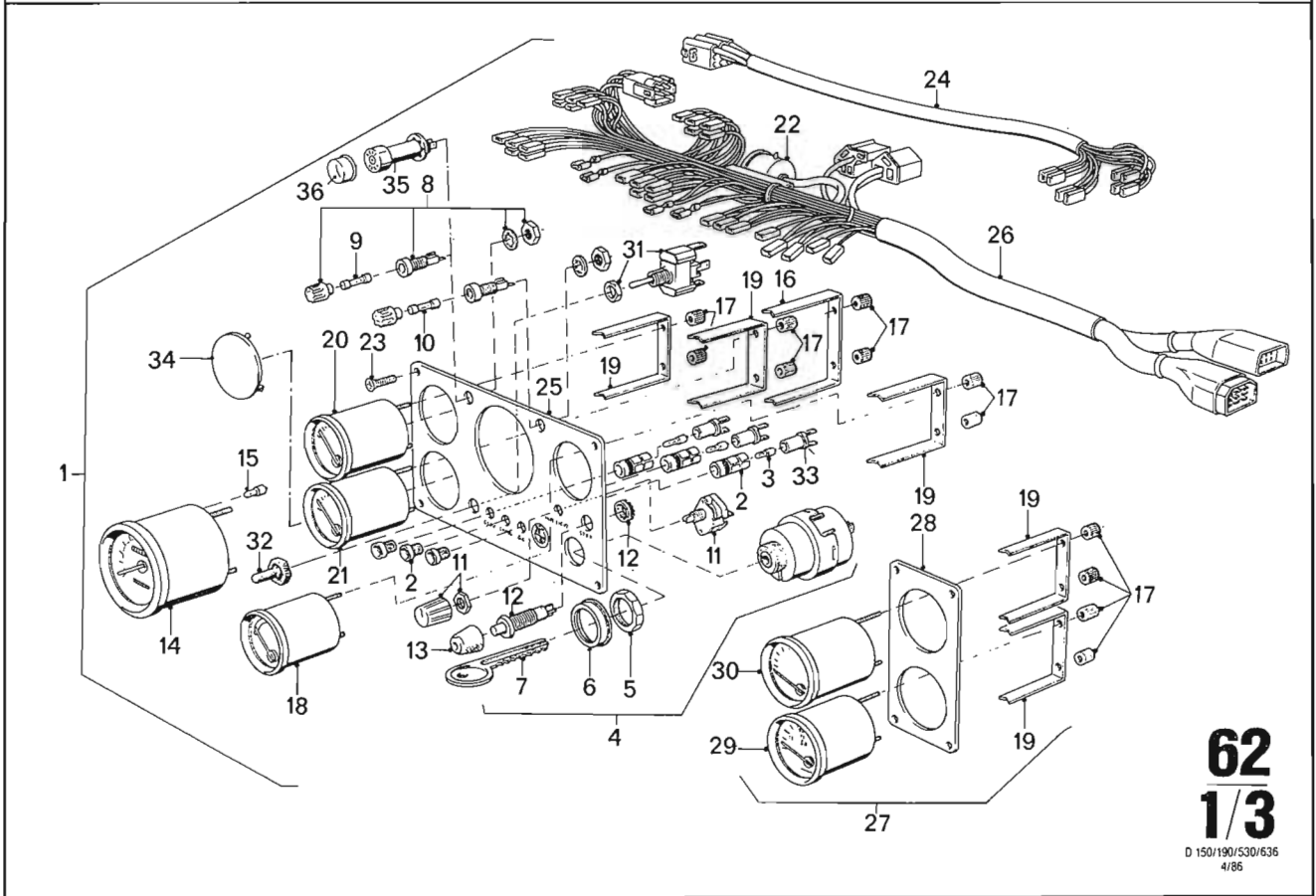

**62**  
**1/3**  
 D 150/190/530/636  
 4/86

<b>62</b> <b>1/3</b>		4/86			D 150	D 190					
Nr.	Teile-Nummer	Symbol	Benennung								Bemerkung
32	61 31 1 333 993		Kappe / Cap / Capuchon / Kåpa / Cappuccio		1	1					
33	62 14 8 680 131		Lampenfassung / Light socket / Pied d'ampule / Lamphållare / Portalampada		3	3					
34	a 62 13 1 333 924		Blinddeckel / Blind cover / Couvercle d'obturation / Blindlock / Coperchio cieco		1	1					
35	c 61 13 1 334 039		8A Schutzschalter / Protective switch / Interrupteur de protection / Skyddströmbrytare / Interruttore di protezione		2	2					
36	c 61 13 1 334 040		Kappe / Cap / Capuchon / Kåpa / Cappuccio		2	2					

a) Nur für Wendegetriebe / For reversing gearbox only / Uniquement pour réducteur-inverseur / Bara för backväxel / Solo per cambio ad inversione di marcia  
 b) → Aggr. Nr. 653 (D150) → Aggr. Nr. 6039 (D190)  
 c) Aggr. Nr. → dito

V12 Engineering  
 www.bmwmarine.com



Instrumententafel – VDO  
 Instrument panel – VDO  
 Tableau des instruments – VDO  
 Instrumenttavla – VDO  
 Cruscotto – VDO

BMW D 150 / D 190 / D 530 / D 636

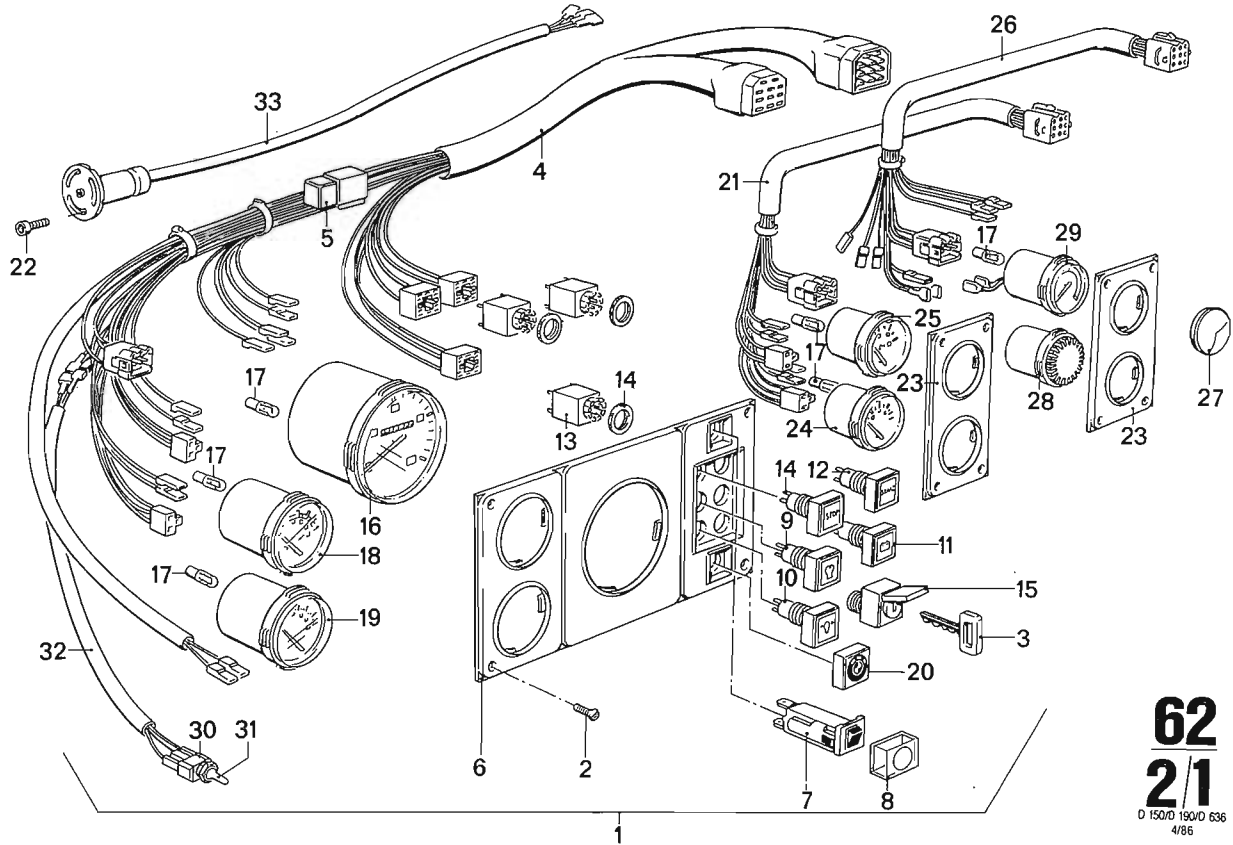

**62**  
**2/1**  
 D 150/D 190/D 530  
 4/86

62 2/1		4/86									
Nr.	Teile-Nummer	Symbol	Benennung	D 150	D 190	D 530	D 636	Bemerkung			
1	a 62 10 1 334 091		kpl. Instrumententafel / Instrument panel / Tableau des instruments / Instrumenttavla / Cruscotto	1	1						
	a 62 10 1 334 320		dito				1				
	b 62 10 1 334 143		dito	1	1						
	b 62 10 1 334 343		dito								
2	07 11 9902 520		B 4 BL SHR	12	12	12	12				
3	61 31 1 334 401		Nr. 93401 Zündschlüssel / Ignition key / Clé de contact / Tändnyckel / Chiavetta dell'avviamento	X	X	X	X				
	61 31 1 334 402		Nr. 93402 dito	X	X	X	X				
	61 31 1 334 403		Nr. 93403 dito	X	X	X	X				
	61 31 1 334 404		Nr. 93404 dito	X	X	X	X				
	61 31 1 334 405		Nr. 93405 dito	X	X	X	X				
	61 31 1 334 406		Nr. 93406 dito	X	X	X	X				
	61 31 1 334 407		Nr. 93407 dito	X	X	X	X				
	61 31 1 334 408		Nr. 93408 dito	X	X	X	X				
	61 31 1 334 409		Nr. 93409 dito	X	X	X	X				
	61 31 1 334 410		Nr. 93410 dito	X	X	X	X				
	61 31 1 334 411		Nr. 93411 dito	X	X	X	X				
	61 31 1 334 412		Nr. 93412 dito	X	X	X	X				
	61 31 1 334 413		Nr. 93413 dito	X	X	X	X				
	61 31 1 334 414		Nr. 93414 dito	X	X	X	X				
	61 31 1 334 415		Nr. 93415 dito	X	X	X	X				
	61 31 1 334 416		Nr. 93416 dito	X	X	X	X				
	61 31 1 334 417		Nr. 93417 dito	X	X	X	X				
	61 31 1 334 418		Nr. 93418 dito	X	X	X	X				
	61 31 1 334 419		Nr. 93419 dito	X	X	X	X				
	61 31 1 334 420		Nr. 93420 dito	X	X	X	X				
	61 31 1 334 421		Nr. 93421 dito	X	X	X	X				
	61 31 1 334 422		Nr. 93422 dito	X	X	X	X				
	61 31 1 334 423		Nr. 93423 dito	X	X	X	X				
	61 31 1 334 424		Nr. 93424 dito	X	X	X	X				
	61 31 1 334 425		Nr. 93425 dito	X	X	X	X				

a) Aggr. Nr. → 6644 (D190) Nur für Z-Antrieb / For gear drive only / Uniquement pour Commande per engranage / Bara för Kugghjulsdrevning / Solo per comando per ingranaggi  
 b) Aggr. Nr. → 863 (D150) 6619 (D190) Nur für Wendegetriebe / For reversing gearbox / Uniquement pour réducteur-inverseur / Bara för backväxel / Solo per cambio ad inversione di marcia

V12 Engineering

www.bmwmarine.com

Instrumententafel – VDO  
 Instrument panel – VDO  
 Tableau des instruments – VDO  
 Instrumenttavla – VDO  
 Cruscotto – VDO

BMW D 150 / D 190 / D 530 / D 636

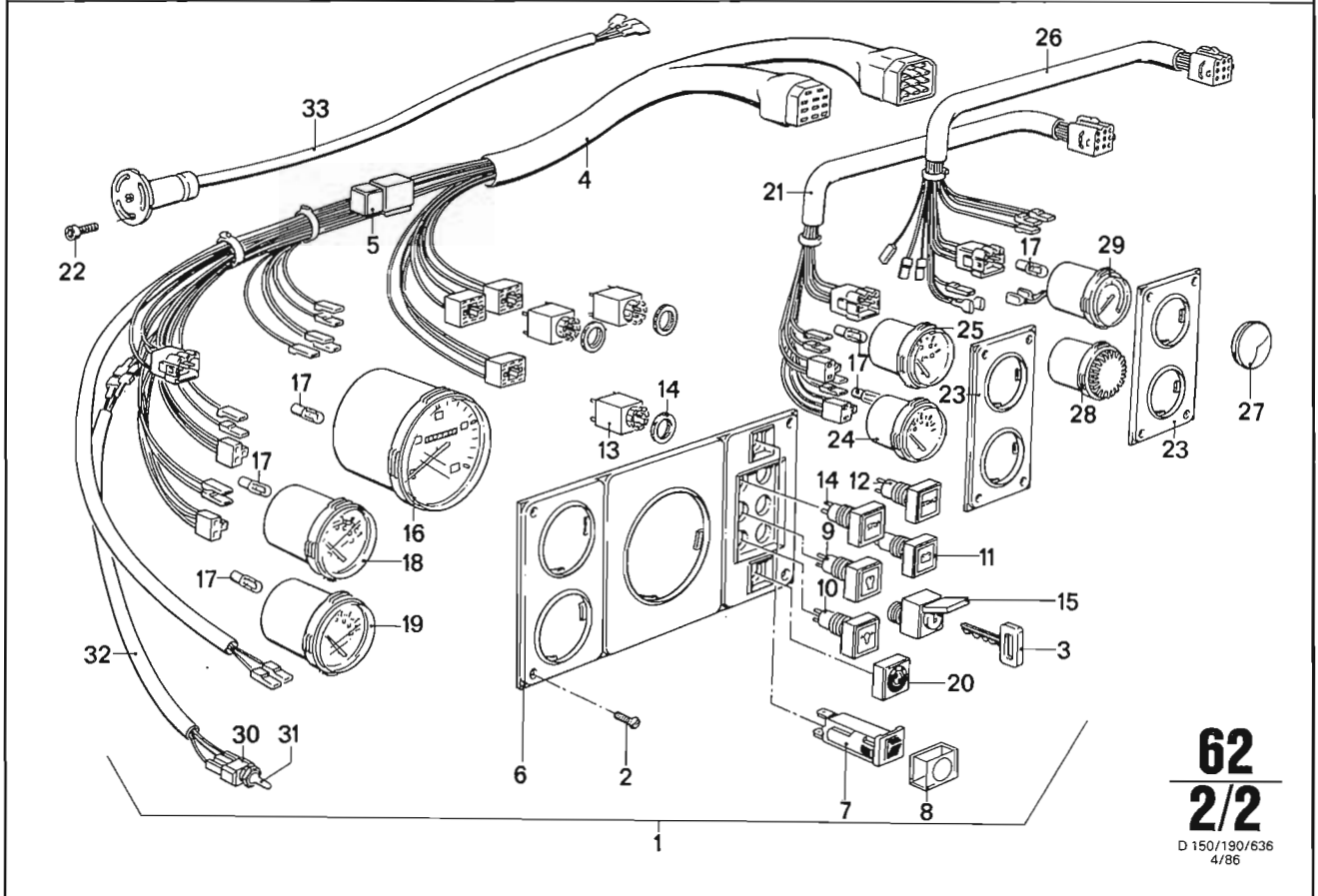

**62**  
**2/2**  
 D 150/190/636  
 4/86

<b>62</b> <b>2/2</b>		4/86							
Nr.	Teile-Nummer	Symbol	Benennung	D 150	D 190	D 530	D 636	Bemerkung	
4	61 11 1 334 098		Kabelbaum-Instrumente / Cable harness – instruments / Faisceau de câbles – instruments / Kabelstam – instrument / Cavi fasciati – strumenti	1	1				
	61 11 1 334 303		dito				1		
5	61 31 1 373 586		Kleinrelais / Minirelay / Relais miniature / Litet relä / Minirelais	1	1				
	61 31 1 334 372		dito				1		
6	62 11 1 334 100		Instrumententafel / Instrument panel / Tableau des instruments / Instrumenttavla / Cruscotto	1	1	1	1		
7	61 13 1 334 307		8 A Schutzschalter / Protective switch / Interrupteur de protection / Skyddströmbrytare / Interruttore di protezione	1	1	1	1		
8	61 13 1 334 308		Schutzkappe / Protection cap / Capot de protection / Skyddskåpa / Cappelot. d. protezione	1	1	1	1		
9	62 14 1 334 101		kpl. Kontrolleuchte – Vorglühen / Telltale lamp – preheating / Lampe témoin – préchauffage / Kontrolllampe – förglödning / Spia luminosa – preriscaldamento	1	1				
	62 14 1 334 326		dito			1	1		
10	62 14 1 334 105		Kontrolleuchte – Öldruck / Telltale lamp – Oil pressure / Lampe témoin – pression d'huile / Kontrolllampe – Oljetryck / Spia luminosa – pressione olio	1	1				
	62 14 1 334 327		dito			1	1		
11	62 14 1 334 106		Kontrolleuchte – Ladekontrolle / Telltale lamp – battery condition Lampe témoin – Indicateur de charge / Kontrolllampe – laddningskontroll / Spia luminosa – controllo carica	1	1				
	62 14 1 334 328		dito			1	1		
12	61 31 1 334 110		Kontrolleuchte – Start / Telltale lamp – start / Lampe témoin – démarrage / Kontrolllampe – start / Spia luminosa – avviamento	1	1	1	1		
13	61 31 1 334 113		Tastkontaktgeber / Touch contactor / Contacteur à touche / Kontaktgivare / Contattore a tasto	3	3	3	3		
14	61 31 1 334 114		kpl. Drucktaster – Stop / Push button – stop / Bouton-poussoir / Tryckknapp – stop / Pulsante a tasto di arresto	1	1	1	1		
15	61 31 1 334 117		Schlüsselschalter / Key-operated switch / Interrupteur à clé / Nyckelströmställare / Interruttore a chiave	1	1	1	1		

**V12 Engineering**  
 Box 50, Ontario, Canada POX 100  
 www.bmwmarine.net

a) Aggr. Nr. → 6644 (D190) Nur für Z-Antrieb / For gear drive only / Uniquement pour Commande per engrénage / Bara för Kugghjulsdrevning / Solo per comando per ingranaggi  
 b) Aggr. Nr. → 863 (D150) 6619 (D190) Nur für Wendegetriebe / For reversing gearbox / Uniquement pour réducteur-inverseur / Bara för backväxel / Solo per cambio ad inversione di marcia

V12 Engineering  
 www.bmwmarine.com

Instrumententafel – VDO  
 Instrument panel – VDO  
 Tableau des instruments – VDO  
 Instrumenttavla – VDO  
 Cruscotto – VDO

BMW D 150 / D 190 / D 530 / D 636

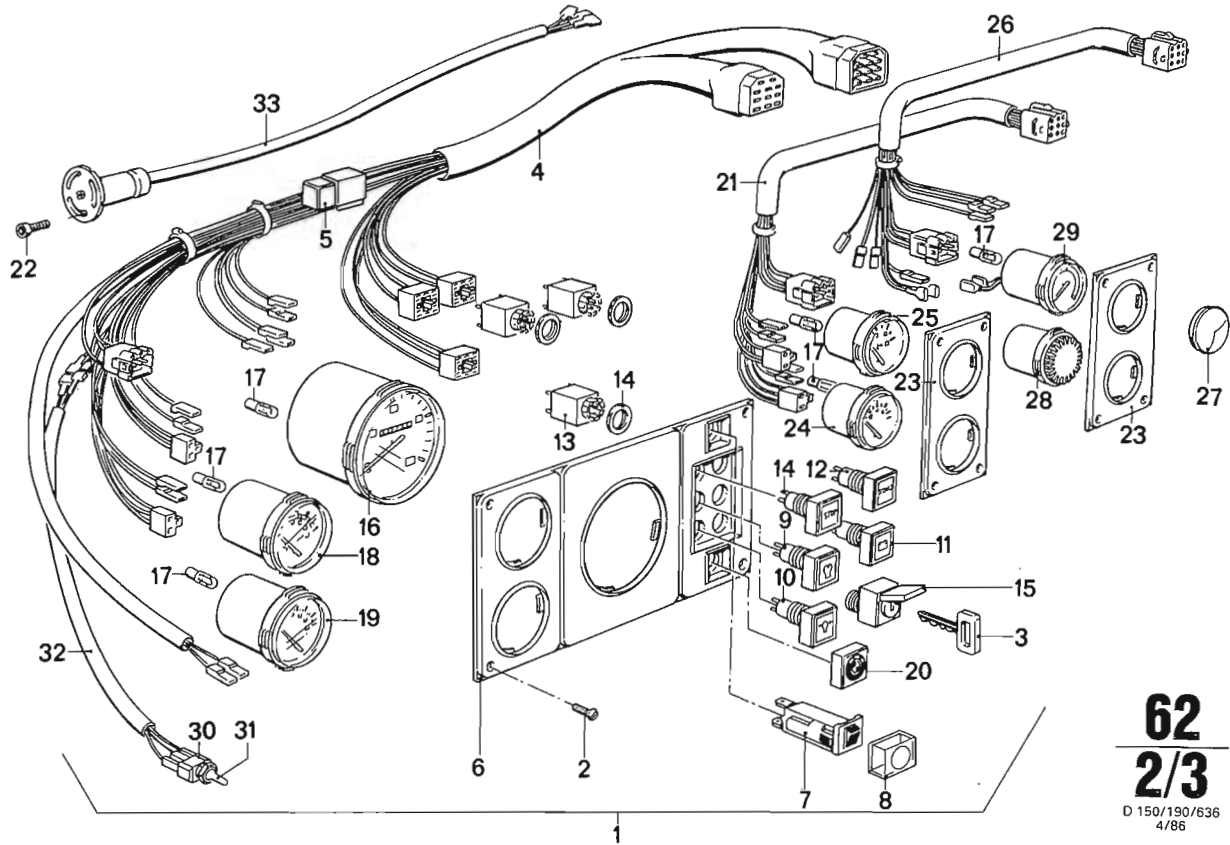

**62**  
**2/3**  
 D 150/190/636  
 4/86

62 2/3		4/86										
Nr.	Teile-Nummer	Symbol	Benennung	D 150	D 190	D 530	D 636					Bemerkung
16	62 13 1334 118		Drehzahlmesser / Tachometer / Compte-tours / Varvtalsmätare / Contagiri	1	1							
	62 13 1334 359		dito			1	1					
	07 11 9978 254		H 12 V 2 W Lampe / Bulb / Lampes / Lamp / Lampada	6	6	6	6					
17	62 13 1334 120		Voltmeter / Voltmeter / Voltmètre / Voltmeter / Voltmetro	1	1	1	1					
18	62 13 1334 120		Wasserthermometer / Water thermometer / Thermomètre d'eau /	1	1	1	1					
19	62 13 1334 121		Vattenthermometer / Termometro per acqua									
20	61 13 1334 153		BMW-Zeichen / BMW-signet / Emblème BMW / BMW emblem / Sigla BMW	1	1	1	1					
21	61 11 1334 122		Kabelbaum / Cable harness / Faisceau de câble / Kabelbom / Fascio di cavi	1	1	1	1					
22	07 11 9907 666		LIN SHR M 4 x 12	3	3	3	3					
23	62 11 1334 124		Instrumententafel / Instrument panel / Tableau des instruments /	2	2	2	2					
			Instrumenttavla / Cruscotto									
24	62 11 1334 125		Öldruckmesser / Oil pressure gauge / Manomètre d'huile /	1	1	1	1					
			Oljetrycksmätare / Manometro pressione olio									
25	62 13 1334 126		Ölthermometer / Oil thermometer / Thermomètre d'huile /	1	1	1	1					
			Oljetermometer / Indicatore temperatura dell'olio									
26	61 11 1334 133		Kabelbaum / Cable harness / Faisceau de câble / Kabelbom /	1	1	1	1					
			Fascio di cavi									
27	b 62 11 1334 216		Blinddeckel / Blind cover / Couvercle d'obturation / Blindlock /	1	1	1	1					
			Coperchio cieco									
28	62 11 1334 129		Summer / Buzzer / Vibreur / Summeranordning / Cicalino	1	1	1	1					
29	a 62 11 1334 130		Trimmanzeige / Trim indicator / Indicateur de trim / Trimindikator /	1	1	1	1					
			Indicatore di trim									
30	a 61 31 1333 992		Kipptaster / Toggle switch / Interrupteur à bascule / Vipptangent /	1	1	1	1					
			Interruttore a bilanciere									
31	a 61 31 1333 993		Gummikappe / Cap / Chapeau de caoutchouc / Gummikåpa /	1	1	1	1					
			Calotta in gomma									
32	a 61 11 1334 209		Anschlußleitung / Lead / Câble de raccordement / Anslutningsledning /	1	1	1	1					
			Cavo di collegamento									
33	a 62 16 1334 203		kpl. Trimmgeber / Trimmer / Transmetteur de compensation /	1	1	1	1					
			Trimmgivare / Trasmittitore di compensazione									

a) Aggr. Nr. → 6644 (D190) Nur für Z-Antrieb / For stern drive only / Uniquement pour Commande per engragene / Bara för Kuggghjusdrivning / Solo per comando per ingranaggi

b) Aggr. Nr. → 863 (D150) 6619 (D190) Nur für Wendegetriebe / For reversing gearbox / Uniquement pour réducteur-inverseur / Bara för backväxel / Solo per cambio ad inversione di marcia

V12 Engineering

www.bmw-motor.com

Instrumententafel – VDO  
 Instrument panel – VDO  
 Tableau des instruments – VDO  
 Instrumenttavla – VDO  
 Cruscotto – VDO

BMW D 150 / D 190 / D 530 / D 636

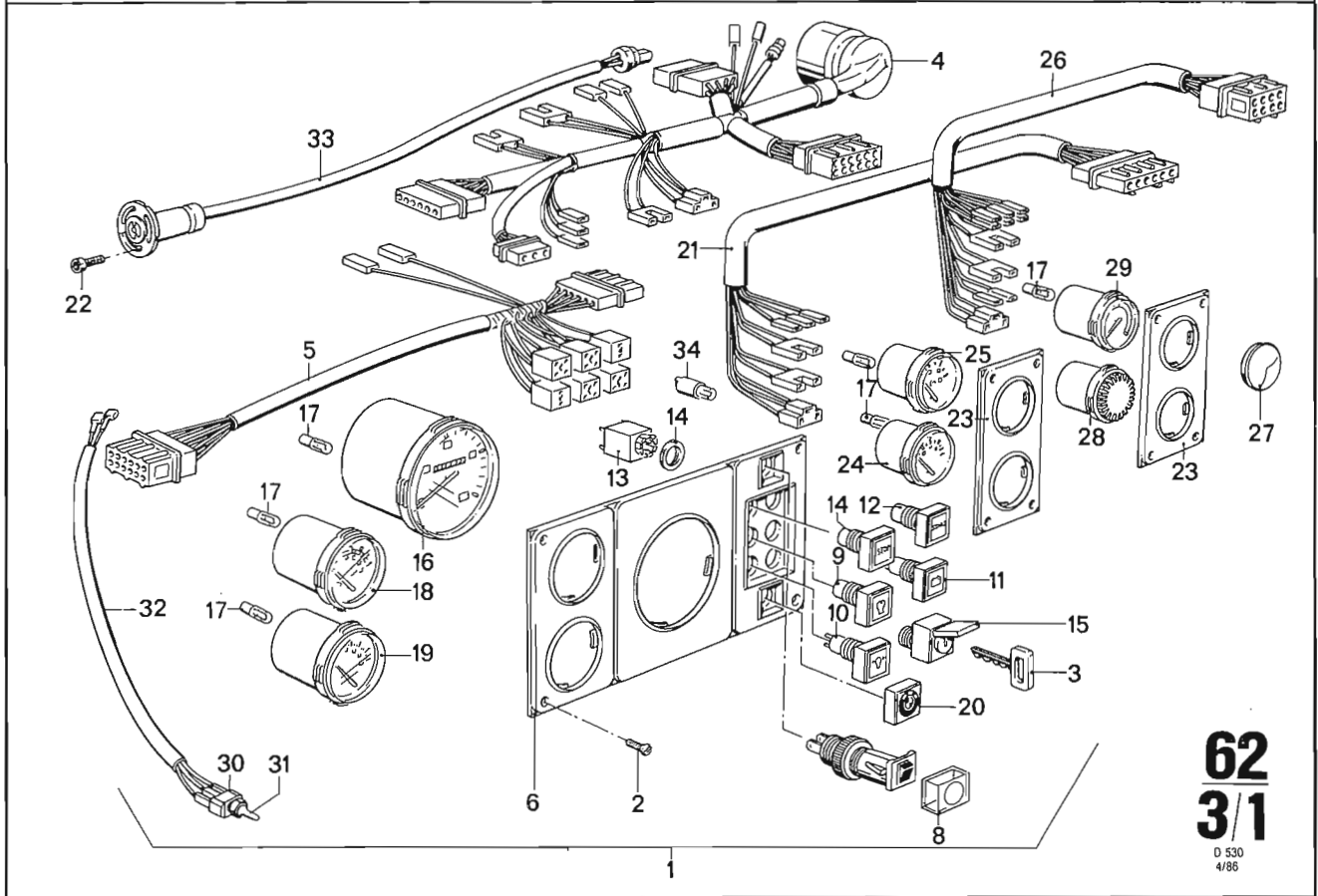

**62**  
**3/1**  
 D 530  
 4/86

62 3/1		4/86									
Nr.	Teile-Nummer	Symbol	Benennung	D 150	D 190	D 530	D 636	Bemerkung			
1	a 62 10 1764 111		kpl. Instrumententafel / Instrument panel / Tableau des instruments / Instrumenttavla / Cruscotto			1					
	b 62 10 1764 112		dito			1					
2	07 11 9902 520		B 4 BL SHR	12	12	12					
3	61 31 1 334 401		Nr. 93401 Zündschlüssel / Ignition key / Clé de contact / Tändnyckel / Chiavetta dell'avviamento	X		X					
	61 31 1 334 402		Nr. 93402 dito			X					
	61 31 1 334 403		Nr. 93403 dito			X					
	61 31 1 334 404		Nr. 93404 dito			X					
	61 31 1 334 405		Nr. 93405 dito			X					
	61 31 1 334 406		Nr. 93406 dito			X					
	61 31 1 334 407		Nr. 93407 dito			X					
	61 31 1 334 408		Nr. 93408 dito			X					
	61 31 1 334 409		Nr. 93409 dito			X					
	61 31 1 334 410		Nr. 93410 dito			X					
	61 31 1 334 411		Nr. 93411 dito			X					
	61 31 1 334 412		Nr. 93412 dito			X					
	61 31 1 334 413		Nr. 93413 dito			X					
	61 31 1 334 414		Nr. 93414 dito			X					
	61 31 1 334 415		Nr. 93415 dito			X					
	61 31 1 334 416		Nr. 93416 dito			X					
	61 31 1 334 417		Nr. 93417 dito			X					
	61 31 1 334 418		Nr. 93418 dito			X					
	61 31 1 334 419		Nr. 93419 dito			X					
	61 31 1 334 420		Nr. 93420 dito			X					
	61 31 1 334 421		Nr. 93421 dito			X					
	61 31 1 334 422		Nr. 93422 dito			X					
	61 31 1 334 423		Nr. 93423 dito			X					
	61 31 1 334 424		Nr. 93424 dito			X					
	61 31 1 334 425		Nr. 93425 dito			X					

V12 Engineering  
 Box 50, Ontario, Canada P0X 1C0  
 www.bmwmarine.net

a) Nur für Z-Antriebmotore / Only for Z drive gears / Uniquement pour les moteurs d'entraînement Z / Bara für Z-Startmotorer / Solo per motori di propulsione Z  
 b) Nur für Wende-Bobtail-Jetmotore / Only for reversing bobtail jet motors / Uniquement pour les moteurs Jet de renversement de marche Bobtail / Bara för Wende-Bobtail-Jetmotorer / Solo per motori-jet-bobtail ad inversione

V12 Engineering  
 www.bmwmarine.com

Instrumententafel – VDO  
 Instrument panel – VDO  
 Tableau des instruments – VDO  
 Instrumenttavla – VDO  
 Cruscotto – VDO

BMW D 150 / D 190 / D 530 / D 636

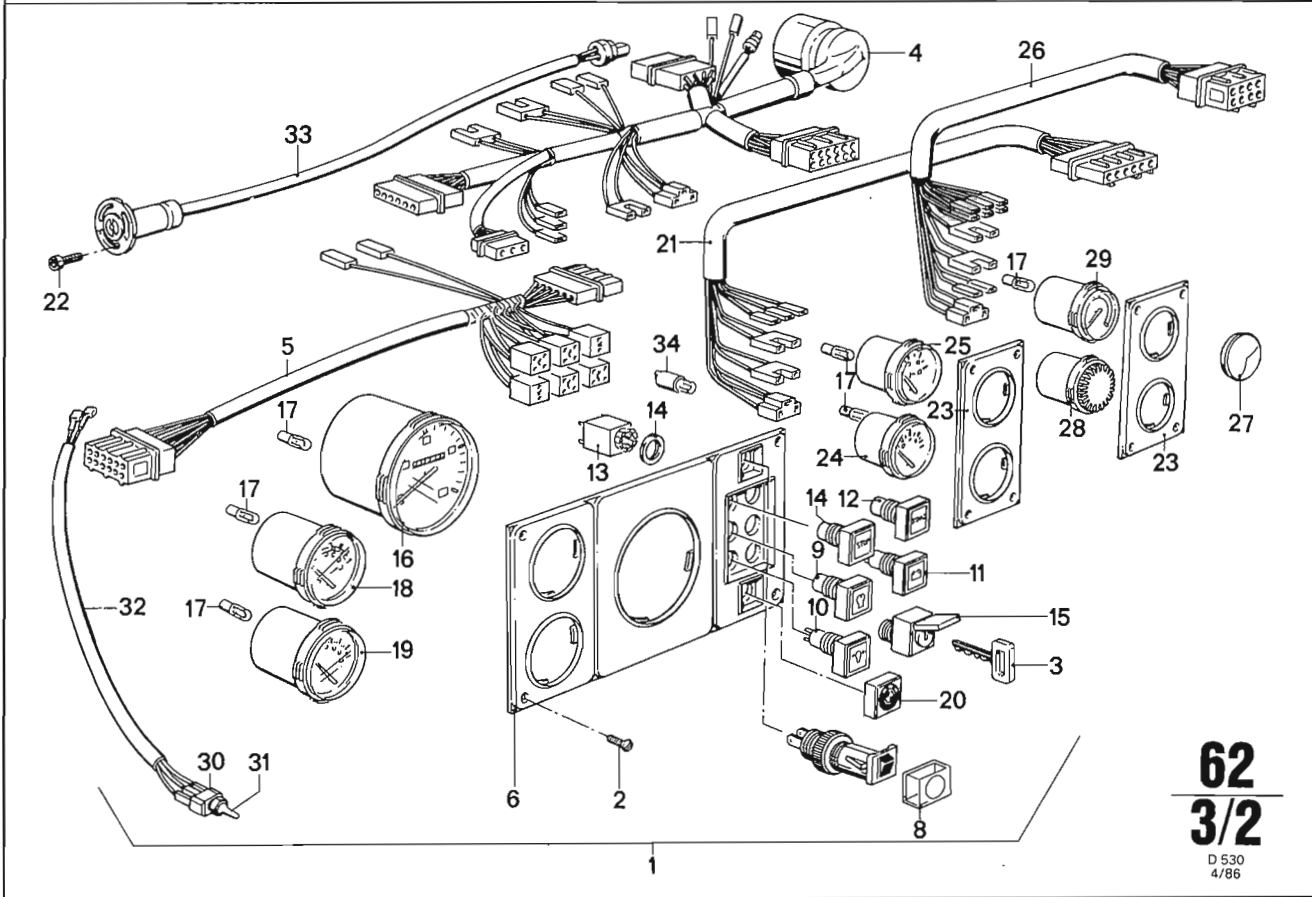

**62**  
**3/2**  
 D 530  
 4/86

<b>62</b> <b>3/2</b>		4/86					D 150	D 190	D 530	D 636	Bemerkung
Nr.	Teile-Nummer	Symbol	Benennung								
4	61 111 764 110		Kabelbaum-Instrumente / Cable harness – instruments / Faisceau de câbles – instruments / Kabelstam – instrument / Cavi fasciati – strumenti						1		
5	61 111 764 019		Kabelbaum / Cable harness / Faisceau de câble / Kabelbom / Fascio di cavi						1		
6	62 111 334 100		Instrumententafel / Instrument panel / Tableau des instruments / Instrumenttavla / Cruscotto				1	1	1	1	
7	61 131 334 307		8A Schutzschalter / Protective switch / Interrupteur de protection / Skyddströmbrytare / Interruttore di protezione				1	1	1	1	
8	61 131 334 308		Schutzkappe / Protection cap / Capot de protection / Skyddskåpa / Cappelot. d. protezione				1	1	1	1	
9	62 141 334 326	kpl.	Kontrolleuchte – Vorglühen / Telltale lamp – preheating / Lampe témoin – préchauffage / Kontrolllampe – förglödning / Spia luminosa – preriscaldamento						1	1	
10	62 141 334 327		Kontrolleuchte – Öldruck / Telltale lamp – Oil pressure / Lampe témoin – pression d'huile / Kontrolllampe – Oljetryck / Spia luminosa – pressione olio						1	1	
11	62 141 334 328		Kontrolleuchte – Ladekontrolle / Telltale lamp – battery condition Lampe témoin – Indicateur de charge / Kontrolllampe – laddningskontroll / Spia luminosa – controllo carica						1	1	
12	61 311 334 110		Kontrolleuchte – Start / Telltale lamp – start / Lampe témoin – démarrage / Kontrolllampe – start / Spia luminosa – avviamento				1	1	1	1	
13	61 311 334 113		Tastkontaktgeber / Touch contactor / Contacteur à touche / Kontaktgivare / Contattore a tasto				3	3	3	3	
14	61 311 334 114	kpl.	Drucktaster – Stop / Push button – stop / Bouton-poussoir / Tryckknapp – stop / Pulsante a tasto di arresto				1	1	1	1	
15	61 311 334 117		Schlüsselschalter / Key-operated switch / Interrupteur à clé / Nyckelströmställare / Interruttore a chiave				1	1	1	1	

Instrumententafel – VDO  
 Instrument panel – VDO  
 Tableau des instruments – VDO  
 Instrumenttavla – VDO  
 Cruscotto – VDO

BMW D 150 / D 190 / D 530 / D 636

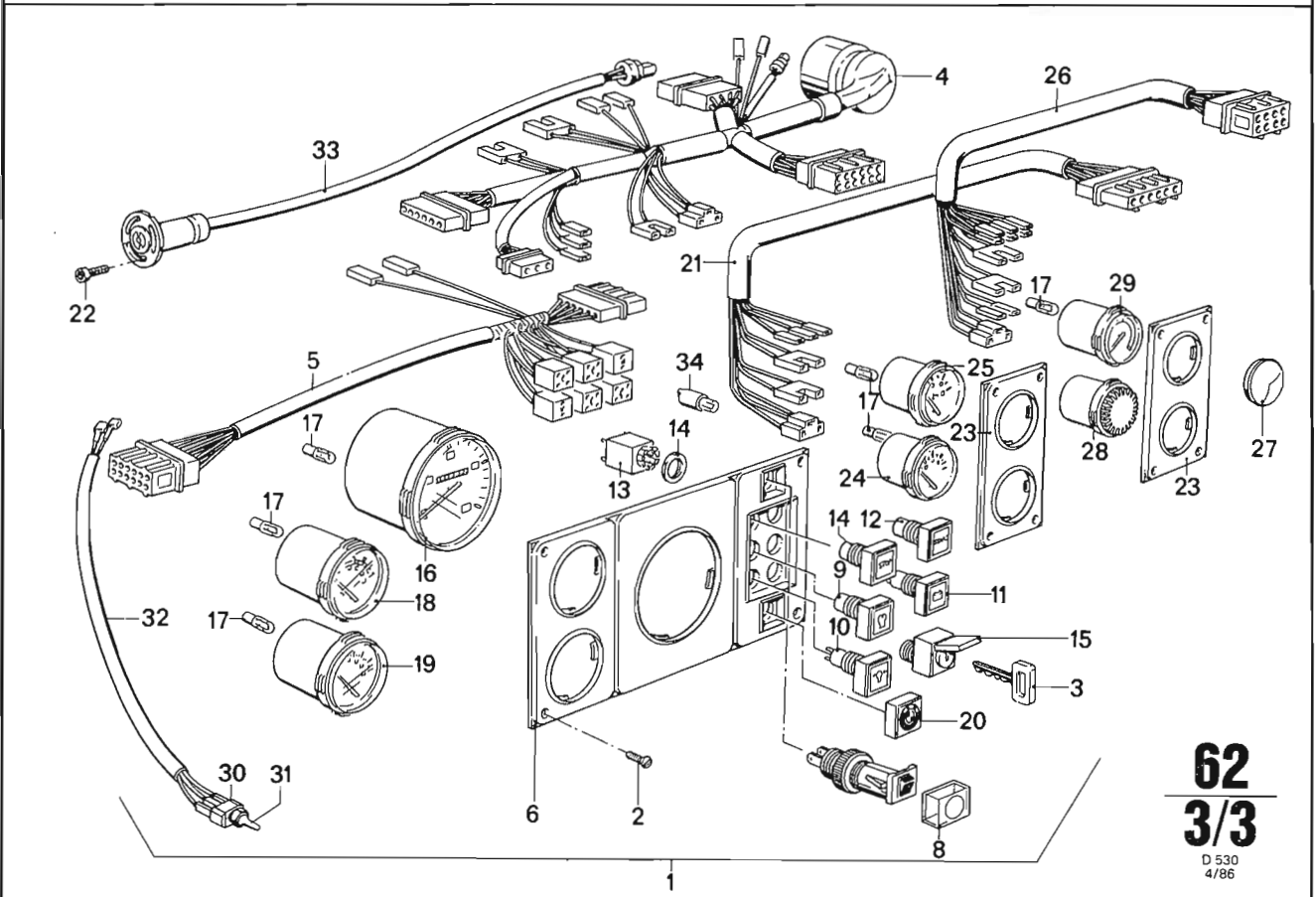

**62**  
**3/3**  
 D 530  
 4/86

<b>62</b> <b>3/3</b>		4/86									
Nr.	Teile-Nummer	Symbol	Benennung	D 150	D 190	D 530	D 636	Bemerkung			
16	62 131 334 359		Drehzahlmesser / Tachometer / Compte-tours / Varvtalsmätare / Contagiri			1	1				
17	07 119 978 254		H 12V 2W Lampe / Bulb / Lampes / Lamp / Lampada	6	6	6	6				
18	62 131 334 120		Voltmeter / Voltmeter / Voltmètre / Voltmeter / Voltmetro	1	1	1	1				
19	62 131 334 121		Wasserthermometer / Water thermometer / Thermomètre d'eau / Vattenthermometer / Termometro per acqua	1	1	1	1				
20	61 131 334 153		BMW-Zeichen / BMW-signet / Emblème BMW / BMW emblem / Sigla BMW	1	1	1	1				
21	61 111 764 014		Kabelbaum / Cable harness / Faisceau de câble / Kabelbom / Fascio di cavi			1					
22	07 119 907 666		LIN SHR M 4 x 12	3	3	3	3				
23	62 111 334 124		Instrumententafel / Instrument panel / Tableau des instruments / Instrumenttavla / Cruscotto	2	2	2	2				
24	62 111 334 125		Öldruckmesser / Oil pressure gauge / Manomètre d'huile / Öljetrycksmätare / Manometro pressione olio	1	1	1	1				
25	62 111 334 126		Ölthermometer / Oil thermometer / Thermomètre d'huile / Öljetermometer / Indicatore temperatura dell'olio	1	1	1	1				
26	61 111 764 014		Kabelbaum / Cable harness / Faisceau de câble / Kabelbom / Fascio di cavi			1					
27	b 62 111 334 216		Blindeckel / Blind cover / Couvercle d'obturation / Blindlock / Coperchio cieco	1	1	1	1				
28	62 111 334 129		Summer / Buzzer / Vibreur / Summeranordning / Cicalino	1	1	1	1				
29	a 62 111 334 130		Trimmanzeige / Trim indicator / Indicateur de trim / Trimindikator / Indicatore di trim	1	1	1	1				
30	a 61 311 333 992		Kipptaster / Toggle switch / Interrupteur à bascule / Vipptangent / Interruttore a bilanciere	1	1	1	1				
31	a 61 311 333 993		Gummikappe / Cap / Chapeau de caoutchouc / Gummikåpa / Calotta in gomma	1	1	1	1				
32	a 62 111 764 017		Anschlußleitung / Lead / Câble de raccordement / Anslutningsledning / Cavo di collegamento			1					
33	a 62 161 334 489		kpl. Trimmgeber / Trimmer / Transmetteur de compensation / Trimgivare / Trasmettitore di compensazione			1					
34	62 141 334 103		Glühlampe / Bulb / Ampoule / Glödlampa / Lampada a incandescenza			5	5				

a) Nur für Z-Antriebmotore / Only for Z drive gears / Uniquement pour les moteurs d'entraînement Z / Bara för Z-Startmotorer / Solo per motori di propulsione Z

b) Nur für Wende-Bobtail-Jetmotore / Only for reversing bobtail jet motors / Uniquement pour les moteurs Jet de renversement de marche Bobtail / Bara för Wende-Bobtail-Jetmotorer / Solo per motori-jet-bobtail ad inversione

V12 Engineering  
 www.bmwmarine.com



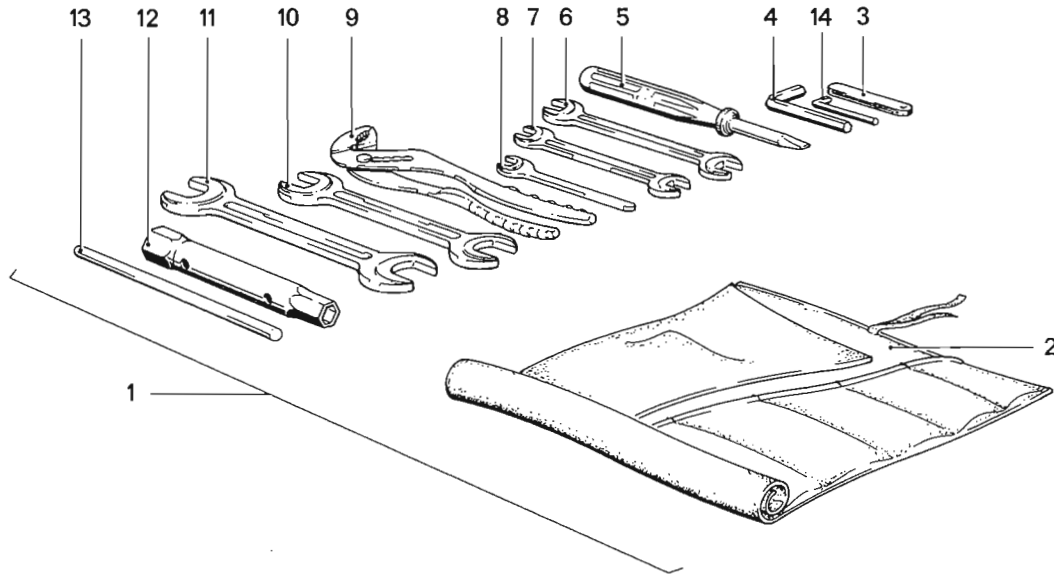

**74**  
**1**

D 150/190/530/636  
4/86

<b>74</b> <b>1</b>											
		4/86									
Nr.	Teile-Nummer	Symbol	Benennung	D 150	D 190	D 530	D 636	Bemerkung			
1	a 7451 1 331 553		kpl. Bordwerkzeug / Tool kit / Trousse d'outils / Verktugsats / Utensile di bordo	1	1	1	1				
2	7451 1 331 003		Werkzeugtasche / Tool bag / Trousse à outils / Verktugsräska / Borsa utensili	1	1	1	1				
3	7451 1 333 567		Fühllehre / Feeler gauge / Goupille / Bladmatt / Calibro a lamelle di spessore	1	1	1	1				
4	07 11 9906 025		6 Schraubendreher / Screw driver / Tournevis / Skurvmejsel / Cacciavite	1	1	1	1				
5	71 11 1 103 086		dito	1	1	1	1				
6	07 11 9999 119		12 x 14 Gabelschlüssel / Open end wrench / Clef / Oppen nyckel / Chiave a bocca fissa	1	1	1	1				
7	07 11 9999 117		10 x 13 dito	1	1	1	1				
8	07 11 9999 050		8 dito	1	1	1	1				
9	71 11 9092 709		Wasserpumpenzange / Water pumping tong / Tenailles à tuyaus / Vattenpumpstång / Pinza pompa acqua	1	1	1	1				
10	07 11 9999 100		17 x 19 Gabelschlüssel / Open end wrench / Clef / Oppen nyckel / Chiave a bocca fissa	1	1	1	1				
11	07 11 9999 141		22 x 24 dito	1	1	1	1				
12	7451 1 331 552		B 13 x 17 Steckschlüssel / Socket wrench / Clef à enfonc. / Sticknyckel / Chiave tubulare	1	1	1	1				
13	07 11 9948 511		A 10 Drehstift / Pin / Goupille / Pinne / Mandrino	1	1	1	1				
14	07 11 9906 020		5 Innensechskantschlüssel / Allen key / Clé pour boulons à six pans creaux / Inre skruvnyckel / Chiave con esagono incassato	1	1	1	1				

a) Standardausstattung / Standard equipment / Equipement standard / Standardutrustning / Equipaggiamento standard



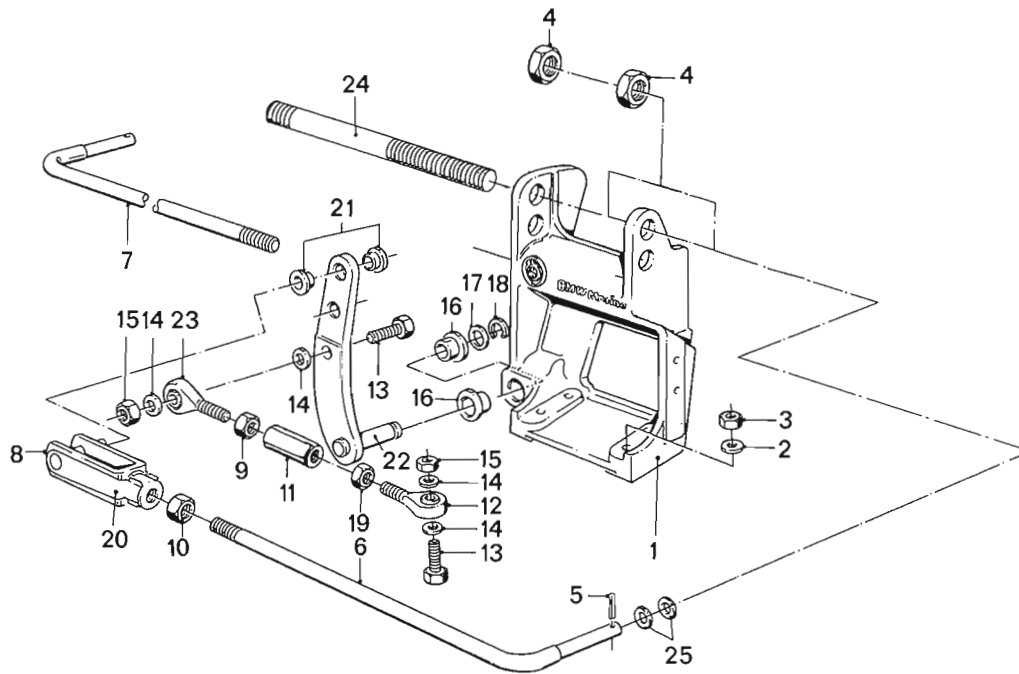

**74**  
**2**

D 150/190/530/636  
4/86

74 2		4/86					D 150	D 190	D 530	D 636	Bemerkung
Nr.	Teile-Nummer	Symbol	Benennung								
1	7492 1 332 484		Gabel / Fork / Chape / Gaffel / Forcella						1	1	
2	07 11 9931 660		8,4 Scheibe / Washer / Rondelle / Bricka / Rondella						4	4	
3	07 11 9922 714		6KT MU M 8						4	4	
4	7492 1 332 067		7/8" 6 KT MU						2	2	
5	07 11 9945 225		4 x 25 Splint / Cotter pin / Goupille fendue / Slint / Copiglia						1	1	
6	a 7492 1 332 315		315 mm Lenkstange / Pitman arm / Guidon / Styrlänkarm / Tirante a sterzo						1	1	
7	b 7492 1 332 314		180 mm dito						1	1	
8	07 11 9987 844		Gabelkopf / Fork head / Fourchette / Gaffelhuvud / Estremo a forcella						1	1	
9	07 11 9921 014		6 KT MU M 12						1	1	
10	07 11 9923 100		6 KT MU M 14						1	1	
11	7492 1 332 237		Verbindungsteil / Link / Pièce de jonction / Förbindelsestycke / Pezzo di unione						1	1	
12	7492 1 332 235		Gelenkkopf / Articulated head / Tête articulée / Ledhuvud / Testa a snodo						1	1	
13	07 11 9913 898		6 KT SHR M 12 x 50						2	2	
14	07 11 9931 674		13 Scheibe / Washer / Rondelle / Bricka / Rondella						4	4	
15	07 11 9922 729		6 KT MU M 12						2	2	
16	7492 1 332 417		Gleitlager / Slide bearing / Palier à glissement / Glidlager / Supporto a scorrimento						2	2	
17	07 11 9932 710		20 x 28 PA SHB						1	1	
18	07 11 9934 132		20 x 1,2 Sicherungsring / Snap ring / Circlip / Låsring / Anello di sicurezza						1	1	
19	07 11 9921 100		6 KT MU M 12						1	1	
20	07 12 9934 959		Sicherungsbolzen / Safety bolt / Boulon de sécurité / Säkringsbult / Spinotto di sicurezza						1	1	
21	7492 1 332 429		Gleitlager / Slide bearing / Palier à glissement / Glidlager / Supporto a scorrimento						1	1	
22	7492 1 332 430		Umlenkhebel / Transmitting lever / Tide de transmission / Överförningsarm / Leva d'inversione						1	1	
23	7492 1 332 236		Gelenkkopf / Articulated head / Tête articulée / Ledhuvud / Testa a snodo						1	1	
24	7492 1 332 077		Führungsrohr / Guide tube / Tube de guidage / Ledningsrör / Tubo d. guida						1	1	
25	07 11 9931 664		10,5 Scheibe / Washer / Rondelle / Bricka / Rondella						2	2	

a) für Steuerbord-Seite / for starboard side / pour côté tribord / for stybordssida / per tribordo  
b) für Backbord-Seite / for portside / pour côté bâbord / för babordssida / per babordo

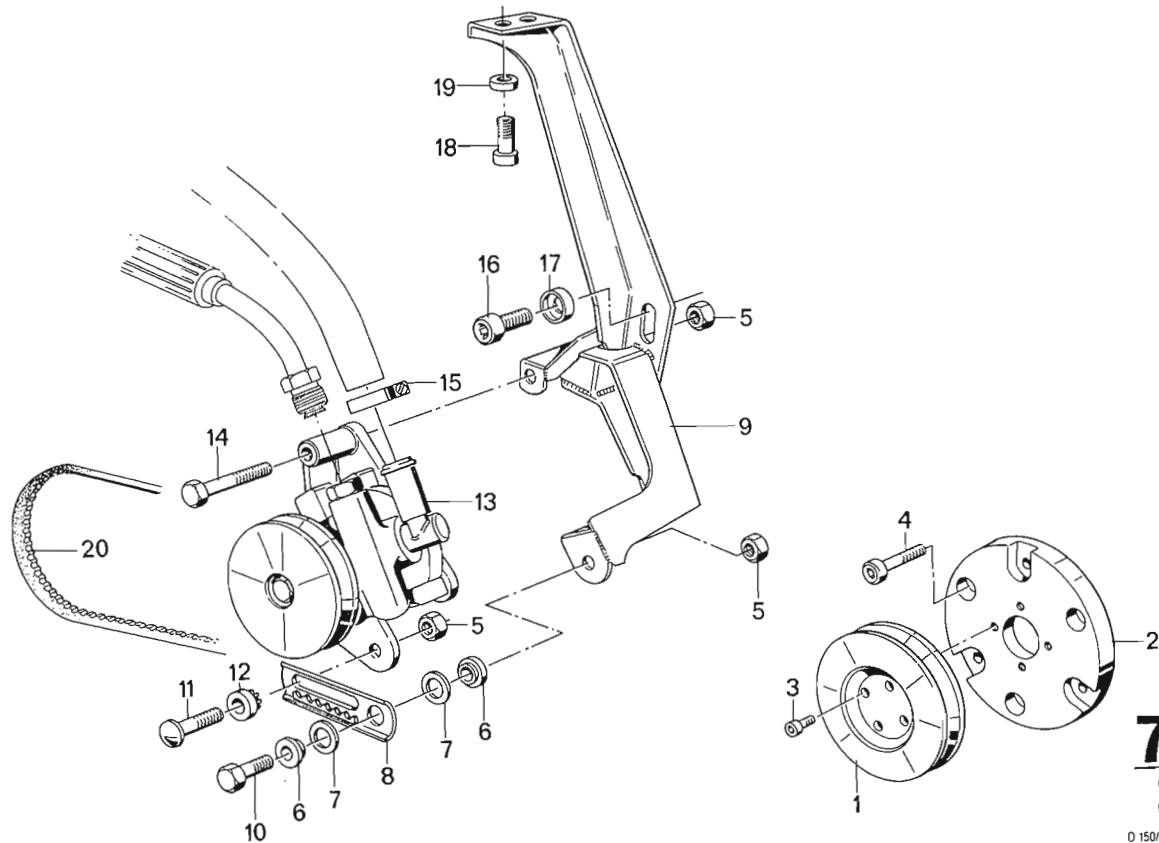

**74**  
**3**

D 150/190/530/636  
4/86

<b>74</b>		4/86							
<b>3</b>									
Nr.	Teile-Nummer	Symbol	Benennung	D 150	D 190	D 530	D 636	Bemerkung	
1	11 511 761 182		Keilriemenscheibe / V-belt pulley / Poulie à gorge / Kitremsskiva / Puleggia della cinghia trapezoidale			1	1		
2	74 921 763 624		Flansch / Flange / Bride / Fläns / Flangia						
3	07 119 919 962		ZYL SHR M 6 × 10			4	4		
4	07 119 919 669		ZYL SHR M 10 × 35			3	3		
5	07 119 922 714		6 KT MU M 8			3	3		
6	11 721 261 404		Buchse / Bushing / Douille / Bussning / Boccola			2	2		
7	32 311 108 620		Scheibe / Washer / Rondelle / Bricka / Rondella			2	2		
8	74 921 763 928		Spannlasche / Tightening clip / Eclisse de réglage / Spännlask / Biscottino di tensione			1	1		
9	74 921 763 927		Abstützung / Propp / Support / Stöttning / Supporto			1	1		
10	07 119 913 657		6 KT SHR M 8 × 25			1	1		
11	32 411 277 375		Flachrundschrabe / Screw / Vis / Skruv / Vite a testa rotondapiatta			1	1		
12	12 311 273 639		Spannritzel / Tension pinion / Pignon de serrage / Spännndrev / Pignone di serraggio			1	1		
13	74 921 763 841		Lenkhilfepumpe / Steering booster pump / Pompe aide directionnelle / Pump för styrhjälp / Pompa servosterzo			1	1		
14	07 119 912 529		6 KT SHR M 8 × 60			1	1		
15	11 531 761 179		20-32 Schelle / Clamp / Collier / Klämma / Fascetta			1	1		
16	07 119 920 066		ZYL SHR M 14 × 25			2	2		
17	07 119 931 682		Scheibe / Washer / Rondelle / Bricka / Rondella			2	2		
18	07 119 919 978		ZYL SHR M 8 × 25			2	2		
19	74 921 763 277		Unterlage / Spacer / Joint / Unterlägg / Piastrina			2	2		
20	74 921 763 283		Keilriemen / V-belt / Courroie trapézoïdale / Kilrem / Cinghia trapezoidale			1	1		

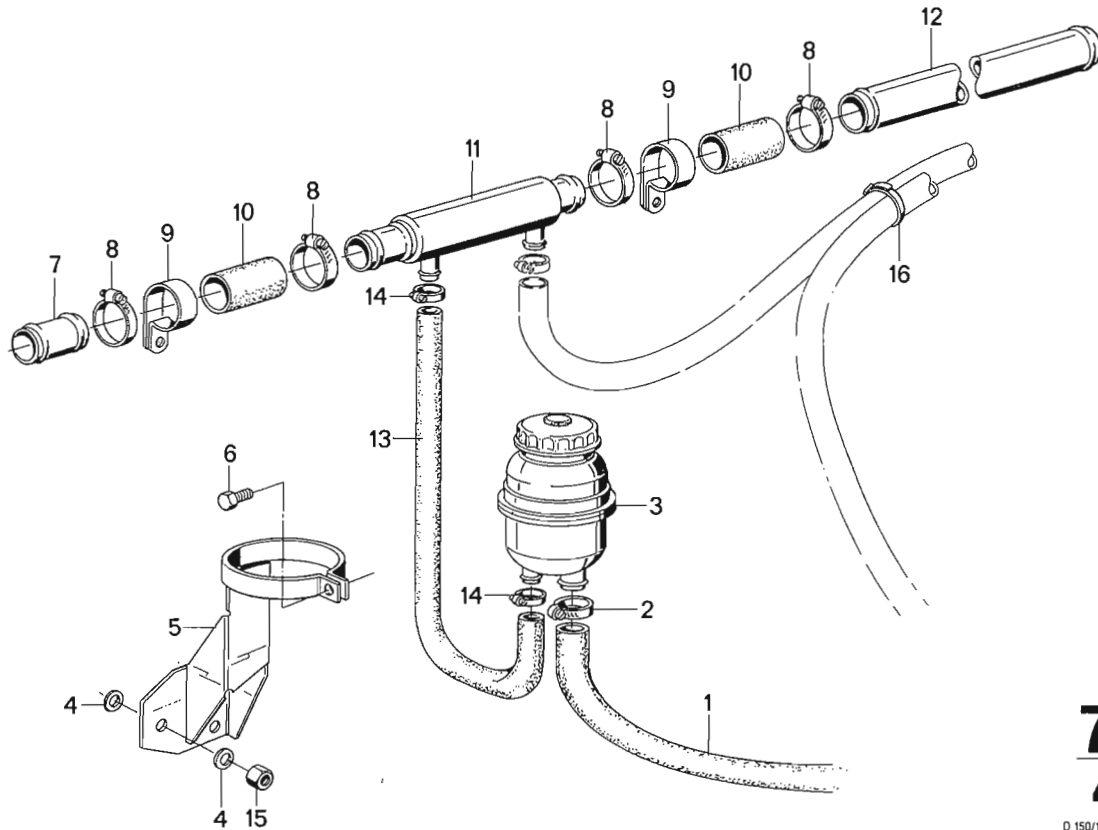

**74**  
**4**

D 150/190/530/636  
4/86

74 4		4/86						
Nr.	Teile-Nummer	Symbol	Benennung	D 150	D 190	D 530	D 636	Bemerkung
1	74 92 1 763 795		Schlauch / Hose / Tuyau / Slang / Tubo flessibile			1	1	
2	11 53 1 761 179		20-32 Schelle / Clamp / Collier / Klämma / Fascetta			1	1	
3	32 41 1 124 680		Ölbehälter / Oil reservoir tank / Carter d'huile / Oljebehållare / Serbatoio dell'olio			1	1	
4	07 11 9 931 067		A 8,4 Scheibe / Washer / Rondelle / Bricka / Rondella			2	2	
5	74 92 1 763 931		Halter / Support / Support / Fäste / Sostegno			1	1	
6	07 11 9 913 446		6KT SHR M 6 x 16			1	1	
7	74 92 1 763 787		Seewasserrohr / Sea water pipe / Tube à eau de mer / Havsvattenrör / Tubo acqua di mare			1	1	
8	11 53 1 326 639		32-50 Schelle / Clamp / Collier / Klämma / Fascetta			4	4	
9	74 92 1 763 789		38 Rohrschelle / Pipe clamp / Bride de tuyau / Rörklämna / Fascetta di tubo			2	2	
10	11 53 1 266 470		Stutzen / Connection / Tubulure / Stuts / Bocchettone			2	2	
11	74 92 1 763 660		Ölkühler / Oil cooler / Réfrigérant d'huile / Oljekylare / Radiatore dell'olio			1	1	
12	74 92 1 763 880		Seewasserrohr / Sea water pipe / Tube à eau de mer / Havsvattenrör / Tubo acqua di mare			1		
	74 92 1 763 788		dito				1	
13	74 92 1 763 794		Schlauch / Hose / Tuyau / Slang / Tubo flessibile			1	1	
14	11 53 1 326 638		16-25 Schelle / Clamp / Collier / Klämma / Fascetta			2	2	
15	07 11 9 909 808		6KT MUM 8			4	4	

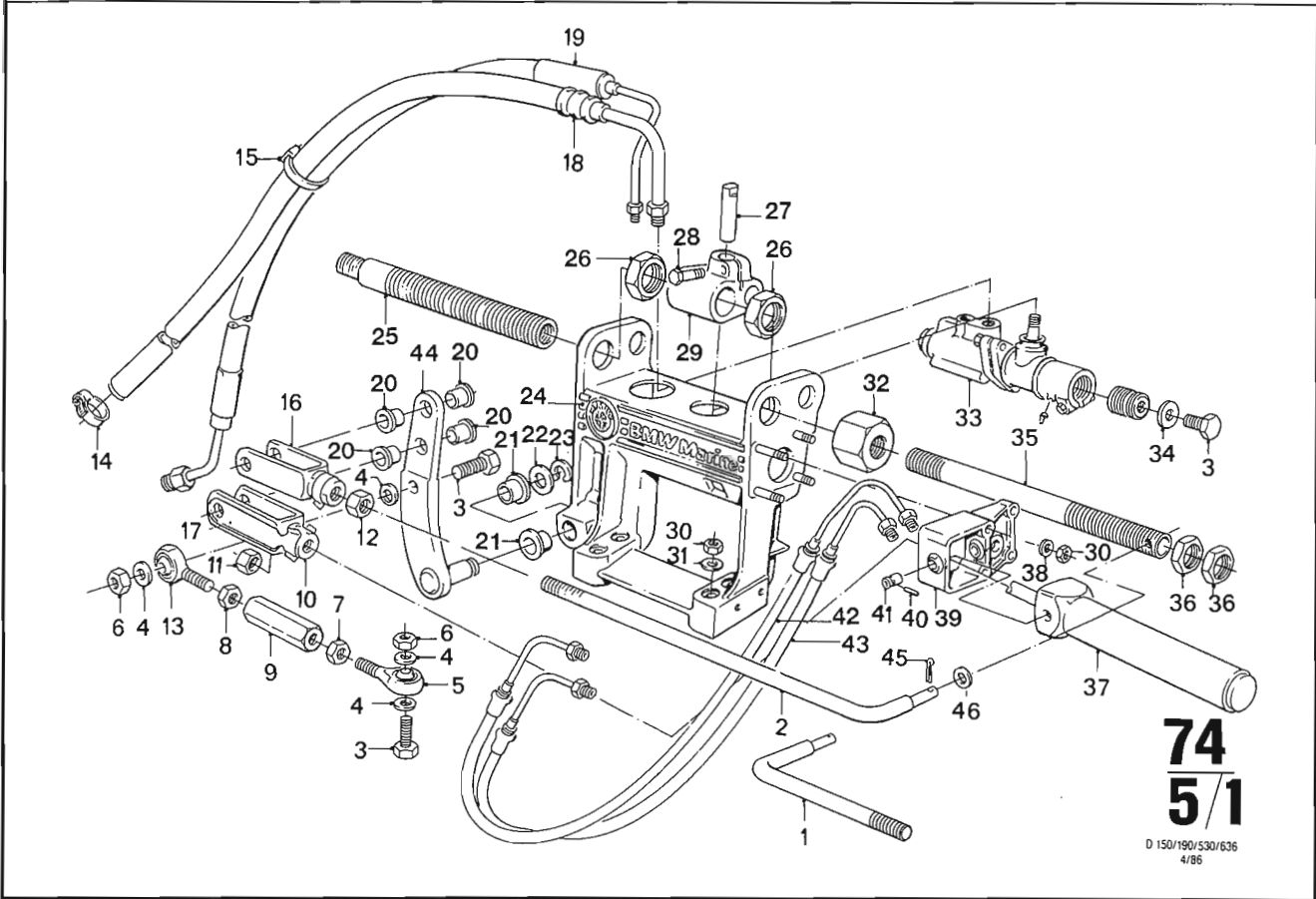

D 150/190/530/636  
4/86

74 5/1		4/86										
Nr.	Teile-Nummer	Symbol	Benennung	D 150	D 190	D 530	D 636					Bemerkung
1	7492 1332 641		150 mm Lenkstange / Handlebar / Barre de direction / Spänn-drev / Manubrio	1	1	1	1					
2	7492 1332 642		350 mm Lenkstange / Handlebar / Barre de direction / Spänn-drev / Manubrio	1	1	1	1					
3	07 11 9913 898		6 KT SHR M 12 x 50	2	2	2	2					
4	07 11 9931 674		13 Scheibe / Washer / Rondelle / Bricka / Rondella	1	1	1	1					
5	7492 1332 236		Gelenkkopf / Knuckle / Articulation / Länk / Articolazione	1	1	1	1					
6	07 11 9912 729		6 KT MU M 12	2	2	2	2					
7	07 11 9921 100		6 KT MU	1	1	1	1					
8	07 11 9921 014		6 KT MU	1	1	1	1					
9	7492 1332 677		Verbindungsteil / Connecting element / Raccord / Förbindelsedel / Elemento di collegamento	1	1	1	1					
10	7492 1332 639		Gabelkopf / Fork / Chape / Gaffel / Forcella	2	2	2	2					
11	7492 1332 333		6 KT MU	1	1	1	1					
12	07 11 9923 100		6 KT MU M 14 x 1,5	1	1	1	1					
13	7492 1332 235		Gelenkkopf / Knuckle / Articulation / Länk / Articolazione	1	1	1	1					
14	11 53 1326 638		16-25 Schelle / Clamp / Collier / Kläm-ma / Fascetta	1	1	1	1					
15	61 13 1354 092		Kabelband / Cable strip / Ruban de câbles / Kabelband / Nastro per cavo	1	1	1	1					
16	07 11 9987 845		Gabelkopf / Fork / Chape / Gaffel / Forcella	1	1	1	1					
17	07 11 9934 959		Sicherungsblech / Lock plate / Tôle de frein / Låsbricka / Lamiera di sicurezza	2	2	2	2					
18	7492 1763 793		Ventil-Ölkühler-Schlauch / Valve-Oil cooler-Hose / Soupape-Réfrigérant d'huile-Tuyau / Ventil-Oljekylare-Slang / Valvola-Radiatore dell'olio-Tubo flessibile	1	1	1	1					
19	7492 1763 792		Pumpe-Ventil-Schlauch / Pump-Valve-Hose / Pompe-Soupape-Tuyau / Pump-Ventil-Slang / Pompa-Valvola-Tubo flessibile	1	1	1	1					
20	7492 1332 429		Lagerbuchse / Bearing bush / Coussinet / Lagerbussning / Boccia di supporto	4	4	4	4					
21	7492 1332 417		Gleitlager / Bearing / Palier / Lager / Supporto	2	2	2	2					
22	07 11 9932 710		Paßscheibe / Spacer shim / Disque d'ajustem. / Passbricka / Disco di aggiustaggio	1	1	1	1					
23	07 11 9934 132		Sicherungsring / Snap ring / Circlip / Låsring / Anello di sicurezza	1	1	1	1					

V12 Engineering  
www.bmwmarine.com

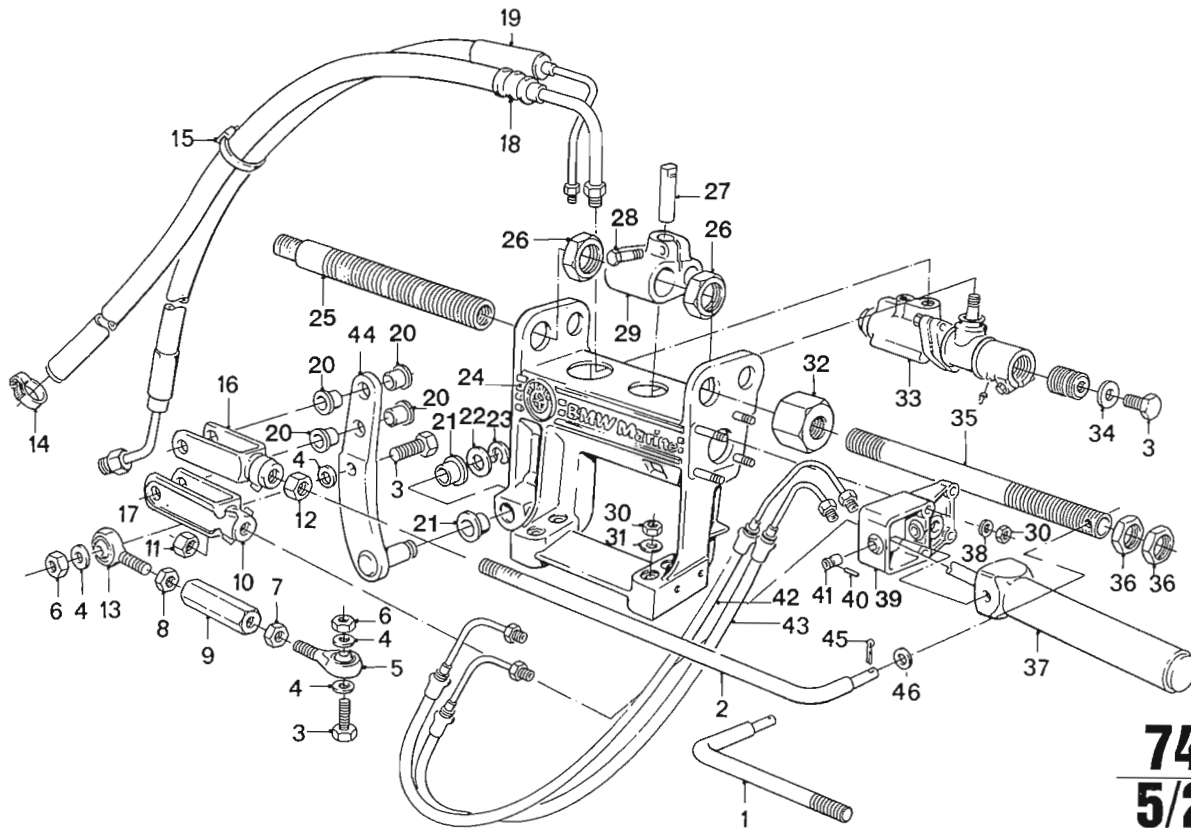

**74**  
**5/2**

D 150/190/530/636  
 4/86

74 5/2		4/86										
Nr.	Teile-Nummer	Symbol	Benennung	D 150	D 190	D 530	D 636					Bemerkung
24	7492 1332 673		Gabel / Fork / Chape / Gaffel / Forcella	1	1	1	1					
25	7492 1332 480		Außenrohr / Tube / Tuyau / Rör / Tubo	1	1	1	1					
26	7492 1332 638		6 KT MU	2	2	2	2					
27	7492 1332 647		Bolzen / Bolt / Boulon / Bult / Bullone	1	1	1	1					
28	07 11 9913 662		6 KT SHR M8 x 30	1	1	1	1					
29	7492 1332 676		Widerlager / Bearing / Palier / Lager / Supporto	1	1	1	1					
30	07 12 9922 714		6 KT MU	8	8	8	8					
31	07 11 9931 660		8,4 Scheibe / Washer / Rondelle / Bricka / Rondella	4	4	4	4					
32	7492 1332 475		Überwurfschraube / Coupling screw / Vis-raccord / Huvskruv / Vite a capello	1	1	1	1					
33	7492 1332 338		kpl. Ventil / Valve / Soupape / Ventil / Valvola	1	1	1	1					
34	07 11 9931 084		13 Scheibe / Washer / Rondelle / Bricka / Rondella	1	1	1	1					
35	7492 1332 478		Innenrohr / Tube / Tuyau / Rör / Tubo	1	1	1	1					
36	07 11 9921 059		6 KT MU M20	2	2	2	2					
37	7492 1332 335		kpl. Zylinder / Cylinder / Cylindre / Cylinder / Cilindro	1	1	1	1					
38	07 11 9931 067		8,4 Scheibe / Washer / Rondelle / Bricka / Rondella	4	4	4	4					
39	7492 1332 635		Haltebock / Mounting bracket / Support / Fixtur / Supporto	1	1	1	1					
40	07 11 9905 420		Gewindestift / Threaded pin / Goupille filetée / Gängstift / Spina filettata	2	2	2	2					
41	7492 1332 668		Bolzen / Bolt / Boulon / Bult / Bullone	2	2	2	2					
42	7492 1763 796		Ölleitung / Oil pipe / Conduite d'huile / Oljeledning / Tubatura olio	1	1	1	1					
43	7492 1763 797		dito	1	1	1	1					
44	7492 1763 231		Umlenkhebel / Transmitting lever / Tide de transmission / Overförningsarm / Leva d'inversione	1	1	1	1					
45	07 11 9945 225		4 x 25 Splint / Cotter pin / Goupille fendue / Splint / Copiglia	1	1	1	1					
46	07 11 9931 664		10,5 Scheibe / Washer / Rondelle / Bricka / Rondella	1	1	1	1					

www.bmw-engineering.com